



[Click Here To View](#)
[Item at](#)

www.GapPower.com

*Sales • Rentals
Parts & Service*



MODEL S150-N18
Narrow Crown
STAPLER

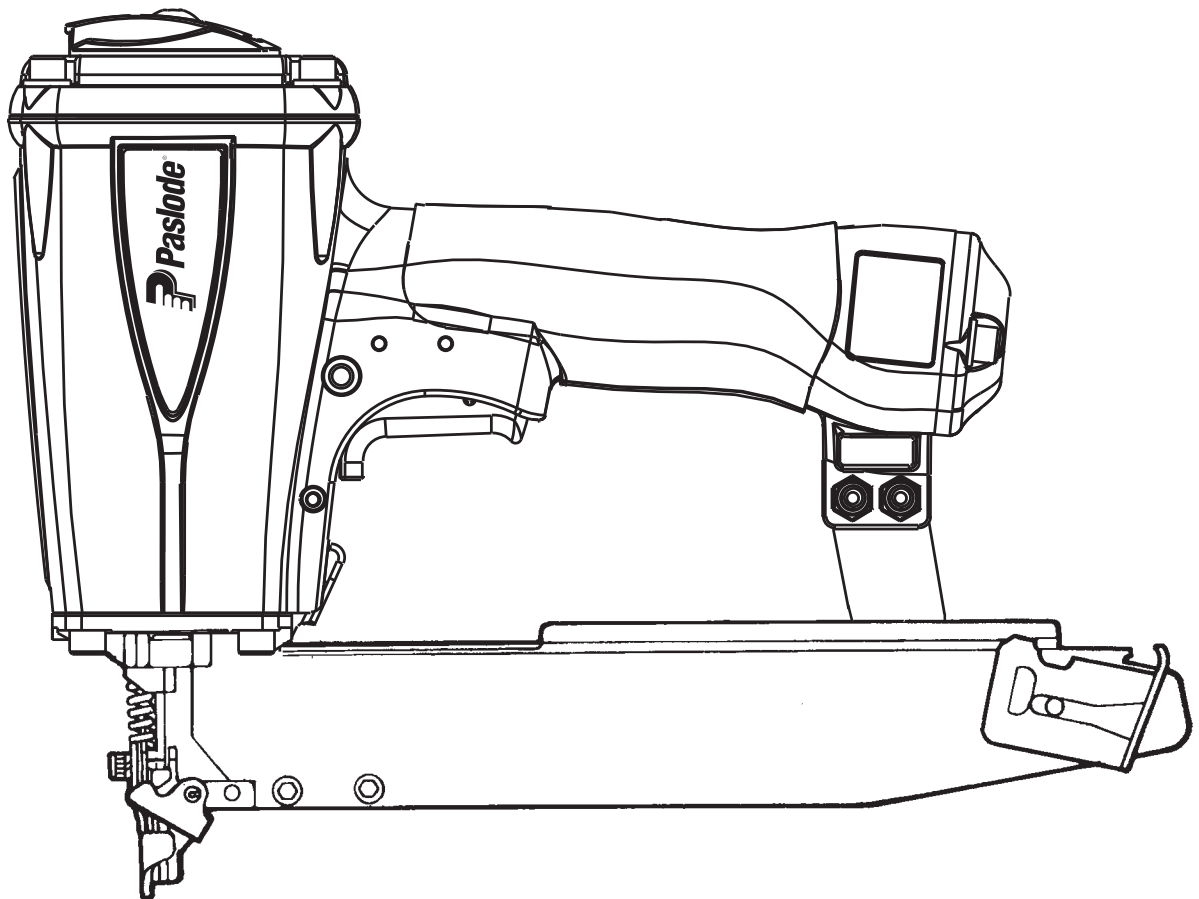

TOOL SCHEMATIC AND PARTS

IMPORTANT!

DO NOT DESTROY

Always refer to safety and operating manuals, #403606, #405218 and #405222 for detailed information on this tool. It is the customer's responsibility to have all operators and service personnel read and understand this information.

PARTS LEGEND S150-N18, 501260

1	501043	1	T.H.S.C.S. 1/4-20 x 1/2	39	402738	1	Spring
2	500956	1	Cap Diffuser	40	402629	2	Hardened Washer
3	501299	6	S.H.C.S. 1/4-20 x 1	41	501243	1	Intermediate W.C.E.
4	501254	1	Cap	42	071297	1	Roll Pin
5	402717	1	Conical Spring	43	403379	1	W.C.E.
*6	404230	1	Retaining Ring	44	402734	1	Spring
7	501250	1	Upper Valve Piston	45	404698	2	Roll Pin Assembly
*8	091542	1	O-Ring	46	403214	1	Front Guide
9	404054	1	Seal, Main Valve	47	009059	3	S.H.C.S. 10-32 x 3/4
10	404056	1	Lower Valve Piston	48	403213	1	Back Plate
*11	090927	1	O-Ring, Main Valve	49	405079	1	Spring, Front Guide Latch
*12	092775	1	O-Ring, Main Valve	50	403215	1	Latch, Front Guide
*13	092773	1	O-Ring, Main Valve	51	092178	1	Roll Pin 5/32 x 1
*14	404256	2	O-Ring, Valve Post, End Plug	52	402730	1	Pivot Pin, Front Guide
15	500954	1	Post Main Valve	53	080326	2	S.H.C.S. 10-32 x 1
16	015660	1	S.H.C.S. 10-24 x 1/2	54	403218	1	Rail
17	403582	1	Blade Nut	55	403221	1	Follower
*18	405430	1	O Ring, Piston	56	403380	2	Spacer, Rail to Bracket
19	501169	1	Piston	57	403376	1	Spacer, Rail Cover
*20	403727	1	Driver Blade	58	403753	1	Rail Cover Assembly
21	501322	1	Sleeve Retainer	59	092037	6	Locknut #10-32
22	402725	1	Seal, Sleeve	60	500459	1	Warning Label
23	405243	1	Flange, Sleeve	61	403219	1	Rail Bracket
24	501251	1	Sleeve	62	500963	1	End Plug
*25	402728	1	O Ring, Sleeve	63	097748	1	Spring, Valve Pin
*26	091966	1	O Ring, Sleeve	64	097746	1	Valve Pin
*27	500369	2	O Ring, Sleeve	65	092174	1	O Ring, Valve Body
28	501227	1	Bumper Retainer	66	026133	2	Roll Pin, 1/8 x 1
29	500975	1	Gasket, Cap	67	401958	1	Valve Body
30	501140	1	Logo, Housing L	68	402668	1	Retaining Washer
31	500957	1	Housing	69	501008	1	Lever, Trigger
32	501141	1	Logo, Housing R	70	501010	1	Trigger
33	402708	1	Gasket, Nose Flange	71	501009	1	Roll Pin
34	501229	1	Bumper	72	402669	1	Pin, Trigger
35	403222	1	Seal, Driver Blade	73	501296	1	Nameplate
36	402706	1	Flange	74	501023	1	Grip Handle
37	091545	4	S.H.C.S. 1/4-20 x 7/8	75	004502	2	S.H.C.S. 10-32 x 5/8
38	403716	2	S.H.C.S. 10-32 x 5/16	76	403217	1	Extension Spring, Follower
				77	501320	1	Guide Block

* Denotes normal wear items.

** Make sure warning label (500459) is properly affixed.
Replace if necessary. Label available at no charge through the Service Dept.

▲ Apply Loctite 242 (Blue) Part No. 093500

→ Denotes new change.

Fastener sizes:

Length: 1/2" to 1-1/2"

Gauge & Crown: 18 ga. 3/16 Crown

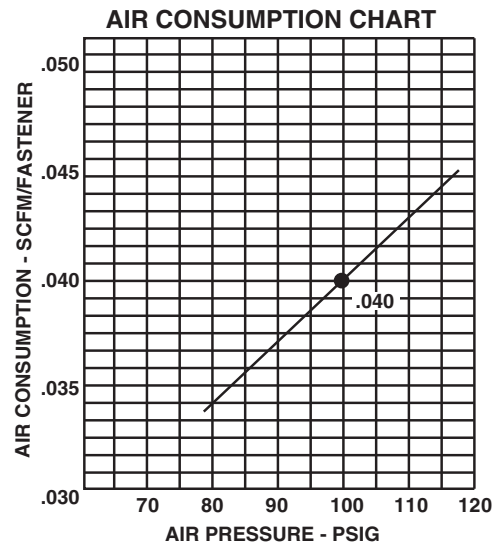

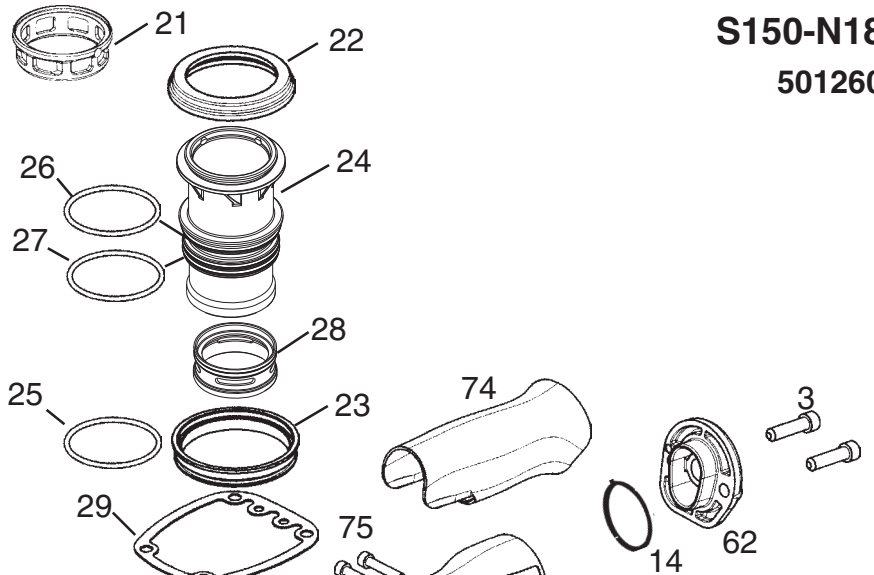
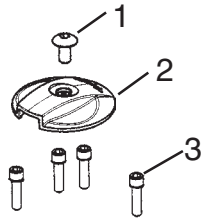

Cap Assembly #501262

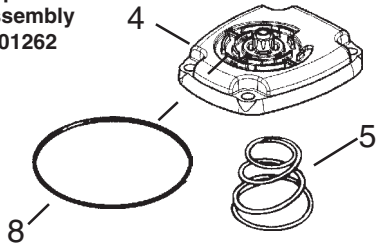

Main Valve Assembly #501261

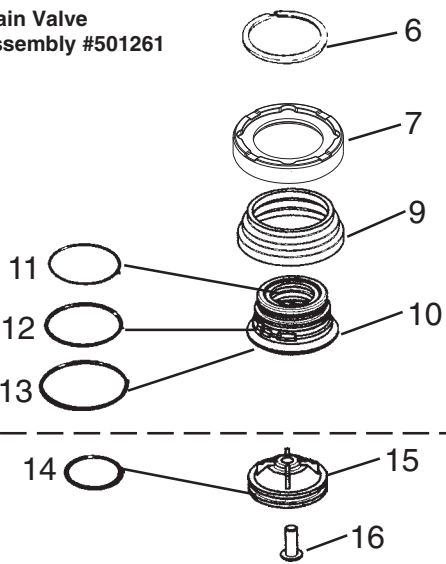

Piston Assembly #501268

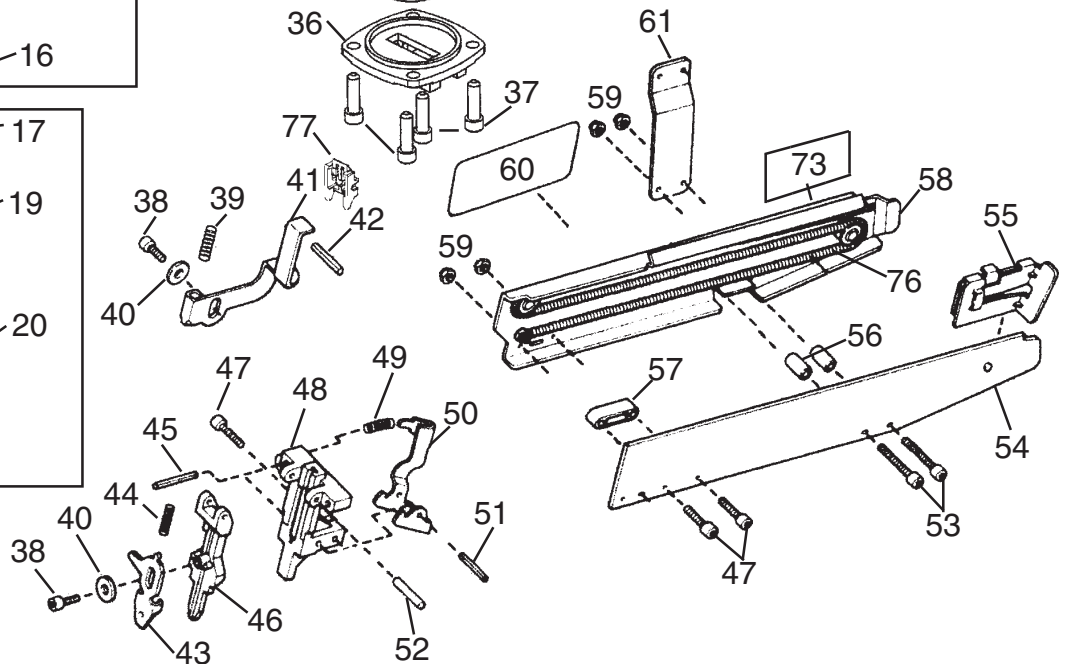
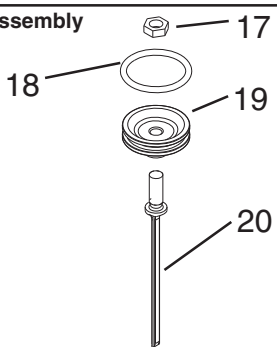

Warning

All parts must be periodically inspected and replaced if worn or broken. Failure to do this can affect the tool's operation and present a safety hazard.

ACCESSORIES

Sequential Operating Kit

This special attachment is designed for sequential operation (stops "contact firing"). The operator must depress and hold the work contacting element against the work surface before pulling the trigger. This sequence must be repeated each time the tool drives a fastener.

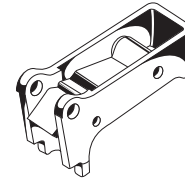

Part No. 501039

Remote Fire Valve

This valve via a positive air signal allows a machine mounted tool to be operated from an automatic air valve or foot pedal system.

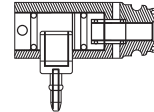

Part No. 1x0713

Trigger Valve Repair Kit

This kit repairs all trigger valve air leaks.

Part No. 219224

Lubricants and Loctite

Loctite 242 (Blue) 10
Lubricating Oil 16 oz.
Lubricating Oil with Antifreeze
Chemplex 710 Lubricant 1 lb.



Part No. 093500
Part No. 403720
Part No. 219090
Part No. 403734

Degreaser Cleaner

Ideal Cleaner for all Paslode Tools



Part No. 219086

Universal Belt Hook

Attaches to cap of tool enabling you to carry tool on belt holder

Part No. 500955

Belt Hook Holder

Attaches to work belt and carries tool using the above belt hook



Part No. 219028

Large Nylon Tool Bag

Part No. 219246

Safety Glasses

Clear



Part No. 402510

SAFETY INSTRUCTIONS

WEAR EYE AND HEARING PROTECTION



Always wear hearing protection and eye protection devices, including side shields when operating or working in the vicinity of a tool.



Never use any bottled air or gases such as oxygen to operate the tool since they could cause the tool to explode.

DO NOT EXCEED MAXIMUM RECOMMENDED AIR PRESSURE

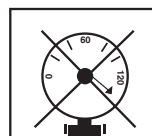

Operate the tool using only the recommended air pressure. Do not exceed the maximum air pressure marked on the tool. Be sure the air pressure gauge is operating properly and check it at least twice a day.

