



TRUSS BOOM WITH WINCH

OPERATOR'S & PARTS MANUAL



PALADIN LIGHT CONSTRUCTION



SERIAL NUMBER: _____

MODEL NUMBER: _____

Manual Number: 76172

Part Number: 76172

Date: April 4, 2006

TABLE OF CONTENTS

PREFACE	3
SAFETY PRECAUTIONS	4-7
SAFETY STATEMENTS	4
GENERAL SAFETY PRECAUTIONS.....	4-6
EQUIPMENT SAFETY PRECAUTIONS	7
INSTALLATION AND OPERATION	9-14
ATTACHING & DETACHING	9
OPERATING EQUIPMENT	9
SPECIAL OPERATING CONSIDERATIONS	9
TULSA WINCH OPERATING & SAFETY MANUAL.....	10-14
MAINTENANCE & SERVICE	15-16
STORAGE	17
GENERAL INFORMATION.....	17
PREPARATION FOR STORAGE	17
REMOVING FROM STORAGE	17
LIMITED WARRANTY	19
PARTS	
3' TRUSS BOOM WITH WINCH ASSEMBLY #11242.....	22-23
3' TRUSS BOOM WITH WINCH ASSEMBLY #12340	24-25
3' TRUSS BOOM WITH WINCH ASSEMBLY #12722	26-27
3' TRUSS BOOM WITH WINCH ASSEMBLY #12637	28-29
3' TRUSS BOOM WITH WINCH ASSEMBLY #12767	30-31
3' TRUSS BOOM WITH WINCH ASSEMBLY #12886	32-33
12' TRUSS BOOM WITH WINCH ASSEMBLY #11141	34-35
12' TRUSS BOOM WITH WINCH ASSEMBLY #11147	36-37
12' TRUSS BOOM WITH WINCH ASSEMBLY #12514	38-39
12' TRUSS BOOM WITH WINCH ASSEMBLY #12746	40-41

FOREWORD

Although The Major has various truss booms available with winches, we are continually designing new sizes and mountings. If your combination is not listed, please contact the factory. We have extensive mounting information available to generate the product you need.

Below is a listing of the truss booms with winches that are currently available. See the "Parts" section of this manual for the assemblies "Shown".

<i>DESCRIPTION & MOUNT</i>	<i>ASSEMBLY #</i>
CASE	
3' Truss Boom With Winch - CASE 688G (Shown)	12637
CATERPILLAR	
3' Truss Boom With Winch - CAT IT/TH (Shown)	12722
12' Truss Boom With Winch - CAT IT/TH (Shown)	12746
INGERSOLL RAND	
3' Truss Boom With Winch - VR843/1044/1056 (Shown)	12637
JCB	
3' Truss Boom With Winch - JCB Q-FIT	11244
3' Truss Boom With Winch - JCB 500 (Shown)	11242
3' Truss Boom With Winch - JCB 407B/409B (Shown)	12340
3' Truss Boom With Winch - JCB 520 HITCH	12845
12' Truss Boom With Winch - JCB Q-FIT (Shown)	11147
JOHN DEERE	
3' Truss Boom With Winch - JD244J (Shown)	12340
LULL	
3' Truss Boom With Winch - LULL 644-944E (Shown)	11242
3' Truss Boom With Winch - LULL 1044C FLAPPER MOUNT (Shown)	12767
12' Truss Boom With Winch - LULL 1044C	12844
MANITOU	
3' Truss Boom With Winch - MANITOU (Shown)	12886
12' Truss Boom With Winch - MANITOU (Shown)	12514
SKYTRAK	
3' Truss Boom With Winch - SKYTRAK (Shown)	11242
12' Truss Boom With Winch - SKYTRAK (Shown)	11141
TEREX	
3' Truss Boom With Winch - TEREX QUICK ATTACH (Shown)	11242
VOLVO	
3' Truss Boom With Winch - VOLVO (Shown)	12340

PREFACE

GENERAL COMMENTS

Congratulations on the purchase of your new attachment! This product was carefully designed and manufactured to give you many years of dependable service. Only minor maintenance, such as cleaning and lubricating, is required to keep it in top working condition. Be sure to observe all maintenance procedures and safety precautions in this manual and on any safety decals located on the product, and on any equipment on which the attachment is mounted. Also, check load charts before operating the attachment.

This manual has been designed to help you do a better, safer job. Read this manual carefully and become familiar with its contents.

WARNING! Never let anyone operate this unit without reading the “Safety Precautions” and “Operating Instructions” sections of this manual.



Always choose hard, level ground to park the vehicle on, and set the brake so the unit cannot roll.

Unless noted otherwise, right and left sides are determined from the operator’s control position when facing the attachment.

NOTE: The illustrations and data used in this manual were current, according to the information available to us at the time of printing. However, we reserve the right to redesign and change the attachment as may be necessary, without notification.

BEFORE OPERATION

The primary responsibility for safety with this equipment falls to the operator. Make sure the equipment is operated only by trained individuals who have read and understand this manual. If there is any portion of this manual or function that you do not understand, contact your local authorized dealer or the manufacturer.

SAFETY ALERT SYMBOL



This is the “Safety Alert Symbol” used by this industry. This symbol is used to warn of possible injury. Be sure to read all warnings carefully. They are included for your safety and for the safety of others working with you.

SERVICE

When servicing your product, remember to use only manufacturer replacement parts. Substitute parts may not meet the standards required for safe, dependable operation.

To facilitate parts ordering, record the model and serial number of your unit in the space provided on the cover of this manual. This information may be obtained from the identification plate located on the product.

The parts department needs this information to ensure that you receive the correct parts for your specific model.

SAFETY STATEMENTS



THIS SYMBOL BY ITSELF OR WITH A WARNING WORD THROUGHOUT THIS MANUAL IS USED TO CALL YOUR ATTENTION TO INSTRUCTIONS INVOLVING YOUR PERSONAL SAFETY OR THE SAFETY OF OTHERS. FAILURE TO FOLLOW THESE INSTRUCTIONS CAN RESULT IN INJURY OR DEATH.



DANGER

THIS SIGNAL WORD IS USED WHERE SERIOUS INJURY OR DEATH WILL RESULT IF THE INSTRUCTIONS ARE NOT FOLLOWED PROPERLY.



WARNING

THIS SIGNAL WORD IS USED WHERE SERIOUS INJURY OR DEATH COULD RESULT IF THE INSTRUCTIONS ARE NOT FOLLOWED PROPERLY.



CAUTION

THIS SIGNAL WORD IS USED WHERE MINOR INJURY COULD RESULT IF THE INSTRUCTIONS ARE NOT FOLLOWED PROPERLY.

NOTICE

NOTICE INDICATES A PROPERTY DAMAGE MESSAGE.

GENERAL SAFETY PRECAUTIONS

WARNING!

READ MANUAL PRIOR TO INSTALLATION



Improper installation, operation, or maintenance of this equipment could result in serious injury or death. Operators and maintenance personnel should read this manual, as well as all manuals related to this equipment and the prime mover thoroughly before beginning installation, operation, or maintenance. **FOLLOW ALL SAFETY INSTRUCTIONS IN THIS MANUAL AND THE PRIME MOVER'S MANUAL(S).**



READ AND UNDERSTAND ALL SAFETY STATEMENTS

Read all safety decals and safety statements in all manuals prior to operating or working on this equipment. Know and obey all OSHA regulations, local laws, and other professional guidelines for your operation. Know and follow good work practices when assembling, maintaining, repairing, mounting, removing, or operating this equipment.



KNOW YOUR EQUIPMENT

Know your equipment's capabilities, dimensions, and operations before operating. Visually inspect your equipment before you start, and never operate equipment that is not in proper working order with all safety devices intact. Check all hardware to ensure it is tight. Make certain that all locking pins, latches, and connection devices are properly installed and secured. Remove and replace any damaged, fatigued, or excessively worn parts. Make certain all safety decals are in place and are legible. Keep decals clean, and replace them if they become worn or hard to read.

GENERAL SAFETY PRECAUTIONS

WARNING!



PROTECT AGAINST FLYING DEBRIS

Always wear proper safety glasses, goggles, or a face shield when driving pins in or out, or when any operation causes dust, flying debris, or any other hazardous material.

WARNING!



LOWER OR SUPPORT RAISED EQUIPMENT

Do not work under raised booms without supporting them. Do not use support material made of concrete blocks, logs, buckets, barrels, or any other material that could suddenly collapse or shift positions. Make sure support material is solid, not decayed, warped, twisted, or tapered. Lower booms to ground level or on blocks. Lower booms and attachments to the ground before leaving the cab or operator's station.

WARNING!



USE CARE WITH HYDRAULIC FLUID PRESSURE

Hydraulic fluid under pressure can penetrate the skin and cause serious injury or death. Hydraulic leaks under pressure may not be visible. Before connecting or disconnecting hydraulic hoses, read your prime mover's operator's manual for detailed instructions on connecting and disconnecting hydraulic hoses or fittings.

- Keep unprotected body parts, such as face, eyes, and arms as far away as possible from a suspected leak. Flesh injected with hydraulic fluid may develop gangrene or other permanent disabilities.
- If injured by injected fluid, see a doctor at once. If your doctor is not familiar with this type of injury, ask him to research it immediately to determine proper treatment.
- Wear safety glasses, protective clothing, and use a piece of cardboard or wood when searching for hydraulic leaks. **DO NOT USE YOUR HANDS! SEE ILLUSTRATION.**

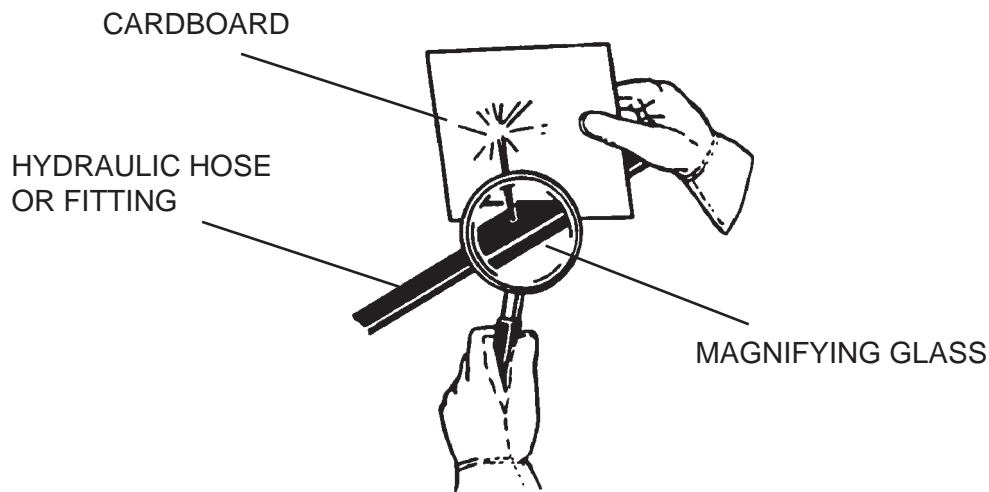

M-807 7-28-05-2

GENERAL SAFETY PRECAUTIONS

WARNING!



DO NOT MODIFY MACHINE OR ATTACHMENTS

Modifications may weaken the integrity of the attachment and may impair the function, safety, life, and performance of the attachment. When making repairs, use only the manufacturer's genuine parts, following authorized instructions. Other parts may be substandard in fit and quality. Never modify any ROPS (Roll Over Protection Structure) or FOPS (Falling Object Protective Structure) equipment or device. Any modifications must be authorized in writing by the manufacturer.

WARNING!



SAFELY MAINTAIN AND REPAIR EQUIPMENT

- Do not wear loose clothing or any accessories that can catch in moving parts. If you have long hair, cover or secure it so that it does not become entangled in the equipment.
- Work on a level surface in a well-lit area.
- Use properly grounded electrical outlets and tools.
- Use the correct tools for the job at hand. Make sure they are in good condition for the task required.
- Wear the protective equipment specified by the tool manufacturer.



SAFELY OPERATE EQUIPMENT

Do not operate equipment until you are completely trained by a qualified operator in how to use the controls, know its capabilities, dimensions, and all safety requirements. See your machine's manual for these instructions.

- Keep all step plates, grab bars, pedals, and controls free of dirt, grease, debris, and oil.
- Never allow anyone to be around the equipment when it is operating.
- Do not allow riders on the attachment or the prime mover.
- Do not operate the equipment from anywhere other than the correct operator's position.
- Never leave equipment unattended with the engine running, or with this attachment in a raised position.
- Do not alter or remove any safety feature from the prime mover or this attachment.
- Know your work site safety rules as well as traffic rules and flow. When in doubt on any safety issue, contact your supervisor or safety coordinator for an explanation.

EQUIPMENT SAFETY PRECAUTIONS

WARNING!



KNOW WHERE UTILITIES ARE

Observe overhead electrical and other utility lines. Be sure equipment will clear them. When digging, call your local utilities for location of buried utility lines, gas, water, and sewer, as well as any other hazard you may encounter.



OPERATING THE PRIME MOVER

Avoid steep hillside operation, which could cause the prime mover to overturn. Extreme caution should be used when working along the top of banks or slopes. Keep away from the edge.

When operating on a slope, keep the load low, and proceed with extreme caution.

Do not drive **ACROSS** a steep slope - drive straight up and down.

With a **LOADED** attachment - face the attachment and load uphill.

With an **EMPTY** attachment - face the attachment downhill.



WORKING WITH THE TRUSS BOOM

- Never use your attachment for a work platform or personnel carrier.
- Specified lift capacities must not be exceeded, otherwise machine stability is not sufficient. Always observe lift capacity limits listed in machine specifications.
- The cable anchor is not intended to hold rated load. Always keep a minimum of five (5) wraps of cable on the drum.
- Always ensure the clutch is fully engaged before lifting or pulling a load.
- Make sure the worm brake is adjusted properly for the load being lifted.
- An operator must not use drugs or alcohol, which can change his or her alertness or coordination. An operator taking prescription or over-the-counter drugs should seek medical advice on whether or not he or she can safely operate equipment.
- Always check locking pins before operating any attachment.
- Never lift, move, or swing a loaded attachment over anyone.
- Do not use the truss boom for towing or pulling horizontally.
- Don't obstruct your vision when traveling or working. Carry the attachment low for maximum stability and visibility.

WARNING!



LARGE OR LOOSE OBJECTS

Use extreme caution when lifting large and/or loose objects. Lifting too high or rolling the boom back could result in these objects swinging. Swinging loads can cause vehicle tipover, which can result in serious injury or death.

INSTALLATION AND OPERATION

ATTACHING AND DETACHING EQUIPMENT

Please see your vehicle operator's manual for instructions on attaching and detaching your equipment.

OPERATING EQUIPMENT

Read all Safety Precautions before operating your new attachment. If a load chart is available, place it inside the operating machine for safe lift capacity limits. The 3' truss boom is rated at 4000 pounds (1814 kg) lift capacity and the 12' truss boom is rated at 2000 pounds (907 kg) lift capacity; these lift capacities should never be exceeded.

Refer to your machine operator's manual for attachment operation.



WARNING!

This product is not designed or intended to lift personnel.

Do not use for towing or pulling horizontally.

Keep all persons and objects clear while any part of this machine is in motion.

The cable anchor is not intended to hold rated load. Always keep a minimum of five (5) wraps of cable on the drum.

Always ensure the clutch is fully engaged before lifting or pulling a load.

Change oil every six (6) months; use EP 140 or equivalent.

If so equipped, lubricate the bushings weekly.

Use extreme caution when lifting large and/or loose objects. Lifting too high or rolling the boom back could result in these objects swinging. Swinging loads can cause vehicle tip-over, which can result in serious injury or death.

BREAKING-IN THE ATTACHMENT

Do not overspeed the winch during cable installation.

To ensure optimum winch performance and life, run at one-half ($\frac{1}{2}$) rated load and line speed for the first thirty minutes of operation.

Make sure the worm brake is adjusted properly for the load being lifted.

See the "Tulsa Winch Operating & Safety Manual" for brake information.

TULSA WINCH OPERATING & SAFETY MANUAL

The following are excerpts from the Tulsa Winch Operating and Safety Manual. We have incorporated these into this manual in an effort to keep all Safety, Operational, and Maintenance information in one document.

INTRODUCTION

Thank you for purchasing a new Tulsa Winch. We are proud of our products and are certain that they will perform your winch tasks properly. However, we do ask that you take a few minutes to read and thoroughly understand this booklet. Also, if you have new operators assigned to the winch, make sure that they read and understand it. Because of the large number of models we manufacture, we are unable to show parts lists for every model in this booklet. If you want or need parts lists, please write or call us at the address at the end of this section.



WARNING!

FAILURE TO HEED THE FOLLOWING WARNINGS MAY RESULT IN SERIOUS INJURY OR DEATH!

- Tulsa winches are not to be used to lift, hoist, or move people. If your task involves lifting or moving people, you **MUST** use the proper equipment, not this winch
- Cable anchors on Tulsa winches are not designed to hold the rated load of the winch. You must keep at least five (5) wraps of cable on the drum to insure that the cable doesn't come loose.
- Stay clear of suspended loads and of cable under tension. A broken cable or dropped load can cause serious injury or death.
- Make sure that all equipment, including the winch and cable, is maintained properly. Pay especially close attention to the clutch, making sure that it fully engages when shifted. Do not attempt to disengage the clutch when a load is on the winch.
- Winches which are not equipped with automatic worm brakes should never be used to lift loads.
- Avoid shock loads. This type of load imposes a strain on the winch many times the actual weight of the load and can cause failure of the cable or of the winch.

WINCH BREAK-IN

Winches, like any other kind of machinery, require a "break in" to perform well and to maximize their life. The following guidelines should be used for breaking-in Tulsa winches.

Use extreme care when first spooling cable onto the winch. Do **NOT** run the winch at high speeds when performing this operation. Make sure that the cable is unrolled in a line (to prevent kinks), and **SLOWLY** inhaul the winch to install the cable.

Do not exceed one-half rated load or one half rated linespeed for the first thirty minutes of operation. This will ensure that the worm and gear have an opportunity to wear-in properly. Periodically, check the gearbox for temperature rises, and allow the winch to cool down between pulls. Worm gear winches are designed and intended for intermittent duty applications only; using them in extremely long pulls may generate excessive heat and shorten the life of the winch.

WINCH OPERATION

To familiarize yourself with the winch, run it for a few minutes to understand the controls and the "feel" of the winch. Pay particular attention to the controls and how they operate. If the winch has air controls on the brake or clutch, or both, operate them to see how they work and the direction of activation of the controls. If the winch is hydraulically powered, make sure you understand which way the winch will rotate when the control lever is moved.

M-558 3-10-06-2

TULSA WINCH OPERATING & SAFETY MANUAL

WINCH OPERATION (Continued)

Always make sure that all people are clear of the load and of the cable area before beginning a winching operation. A broken cable can fly in any direction.

If you are using a mechanically powered winch, learn to pay close attention to the truck engine to sense possible overload. If using a hydraulic winch, do not attempt to defeat the relief valve. If you have any doubts about the capability of the winch to lift or move a load, either put a “snatch block” in the line or get a bigger piece of equipment.

The typical winch operating cycle consists of the following steps:

- (a) Disengaging the winch drum clutch and pulling off enough cable to allow hooking the load. If the winch is equipped with a manually operated drum brake, use it to keep the cable from “bird’s nesting” while being pulled off. **DO NOT** get into the habit of powering off cable; all this does is shorten the life of the winch, especially the winch brake.

NOTE: The drum brake is for free-spooling cable only. It is not intended to be a load-holding brake, and must not be used as such.

- (b) After hooking to the load, engage the drum clutch and release the drum brake, if the winch is so equipped. Make sure the clutch is fully engaged.
- (c) Begin winching the load slowly, watching carefully to insure that the load is moving normally and that no one is in the immediate area of the load or of the cable.
- (d) When the load is positioned where you want it, stop the winch. If the load is suspended, the automatic worm brake will hold it until you are ready to lower it.

CABLE CONSIDERATIONS

As the number of layers of cable on a winch increases, the rated capacity of the winch goes down. If you are operating at near the top of the drum flanges, the effective rating of the winch is about half of what it is on the first layer. You should, therefore, only keep as much cable on the winch as you need for your job.

Never use larger or smaller cable on your winch than is recommended for it. The use of larger cable will not allow you to pull larger loads and may, in fact, break easier than the proper size cable. The use of smaller cable may overheat the winch due to the increased running time with more cable.

The attached chart shows the recommended cable sizes for Tulsa winches.

Consult your local cable supplier for recommendations on the best type of cable and hardware to use in your specific application.

Model	Cable Size (Inches)
5	3/8
938	7/16
1138	7/16
1000	7/16
1200	1/2
10	1/2
12	1/2
18	5/8
18G	5/8
19	5/8
23	5/8
24	3/4
34	3/4
64	7/8
70	1
75	1
80	1

WINCH MAINTENANCE

A winch, like other types of machinery, needs to have regular maintenance if it is to perform properly, give lasting value, and provide safe winching. Good maintenance consists of two parts, a daily inspection and a periodic servicing.

Each day, or after every one hour of winch use, the following items should be inspected and adjusted, if necessary:

1. If the winch is mechanically driven, check all drive components for alignment and tight mounting. If it is hydraulically driven, check for leaks and for proper fluid level in the hydraulic reservoir.
2. Check the cable for excessive wear, for broken strands, and lubrication.
3. Check the automatic worm brake for proper adjustment and adjust it if necessary.
4. Check the drum clutch to make sure it is fully engaging when shifted in. Make adjustments if necessary.

M-559 3-10-06-2

TULSA WINCH OPERATING & SAFETY MANUAL

WINCH MAINTENANCE (Continued)

Once a week, or every 20 hours of operation, the following tasks should be performed for proper maintenance of your winch:

1. Lube all bushings which are equipped with grease zerks with a good quality lithium-based chassis lube.
2. Inspect the oil level in the winch gearbox, and add lubricant if necessary.
3. Lubricate the cable, based on your wire rope supplier's recommendations.
4. If the winch is equipped with a shoe-type brake, inspect the shoes and drum for wear and replace if necessary.

Every six months, the gearbox should be drained and filled with new clean gear lubricant. All Tulsa worm gear winches are filled at the factory with EP140 gear lube, which is ideal for most conditions. If the ambient temperatures where your winch will be working will not exceed 30 degrees F., you can use EP90; likewise, if the temperature will always be over 100 degrees F., you probably should use EP250.

Some Tulsa winches may have been modified to be mounted in other than the normal attitude, which is with the worm horizontal and below the level of the output shaft. If your winch is mounted in another attitude, there may be a special plug which determined the oil level required in your winch. If you have any questions, please contact the factory.

The chart shows the oil capacities for Tulsa winches:

Model	Capacity (Pints)
5	1
938	1-1/2
1138	1-1/2
1000	2
1200	2
10	3
12	3
18	6
18G	6
19	6
23	6
24	6
34	6
64	10
70	10
75	10
80	15

WINCH MODEL CODES

All Tulsa winches have the model, serial number, and assembly number stamped both on the identification tag and on the housing. Please take a few minutes to record these numbers for future use. The assembly number will be required when ordering parts.

MODEL _____

SERIAL NO. _____

ASSEMBLY NO. _____

WINCH MODEL CODES

H 23 — S L R F O — D C L

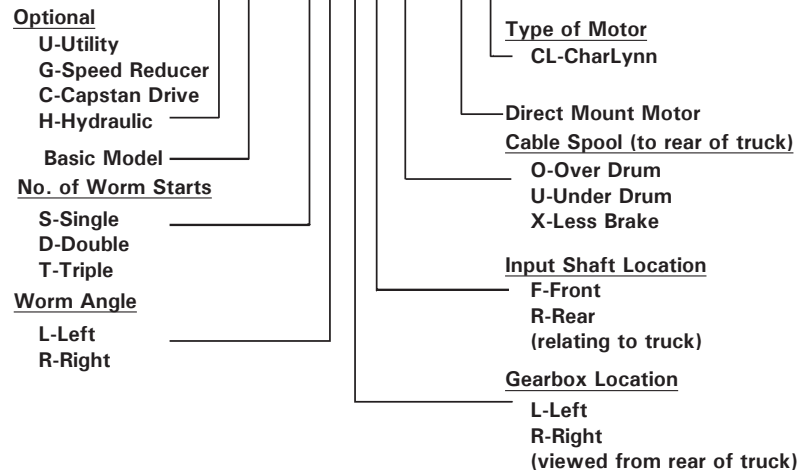

AUTOMATIC WORM BRAKES

Most Tulsa winches are equipped with an automatic worm brake to hold suspended loads. If your winch is not equipped with one, it is intended for pulling loads only. If you wish to lift and suspend loads with your winch, it can be retrofitted with an automatic worm brake. Please consult the factory for details.

The worm brake is an important safety feature of your winch and must be maintained properly. There are three types of worm brakes used on Tulsa winches:

1. Wrap-around band brakes. These are mounted on the worm and are not to be confused with the drum-mounted band brakes on larger winches.
2. Automotive-style shoe brakes.
3. Multiple-disc wet brakes.

M-560 3-10-06-2

TULSA WINCH OPERATING & SAFETY MANUAL

AUTOMATIC WORM BRAKES (Continued)

Each of these worm brakes is designed to operate in the same manner. As a load is hauled in, the brake is released and the load is moved or raised. As the load is stopped, the brake engages and prevents it from falling. When the operator begins to pay out cable to lower the load, he must overcome the drag of the brake to lower the load.

In order for the brake to operate properly, it must be set to engage in the payout mode. To check this, run the winch for one minute under no load in both directions at low speeds. If there is evidence of heat build-up in the payout direction, the brake is installed properly. If the heat rise occurs in the inhaul direction, the brake is installed backward and must be changed.

Most winches are set up to spool over the drum to the load. You can check your model code to determine this. If the winch is set up in this manner and you decide to spool the cable under the drum, you must reverse the direction of brake engagement.

The most common brake for Tulsa winches is the automotive-style shoe brake. This brake uses two shoes in a brake drum to hold winch loads. Models 10 through 34 with shoe brakes have a reversible cam; the 64, 70, and 80 require installation of a new cam to change the direction of braking. The illustration on the right shows the end cover of the typical shoe brake and how to adjust it.

To tighten the brake, loosen the two capscrews in the slotted holes and rotate the brake in the direction shown. If the brake on a Model 10 through 34 needs to be reversed, remove those same two capscrews, rotate the cam 60 degrees in the loosening direction, and reinstall the capscrews in the new set of holes which have just been revealed. After adjustment, be sure to re-tighten the cam capscrews securely.

Another type of brake, used on the Models 5, 6, 8 and some older winches is the band brake. Two assemblies of the band brake are shown to the right, with the cover removed to view the interior.

The direction in which this brake works can be reversed by removing the band from the brake, turning it over, and reinstalling it.

The Models **938**, 1138, 1060, and 1242 are equipped with an adjustable, multiple disc oil brake. This brake is adjusted by loosening the jam nut and turning the capscrew inward.

Some versions of the Models 10 through 80 are equipped with a multiple disc oil brake which is not adjustable. These winches can be identified by the warning on the cover.

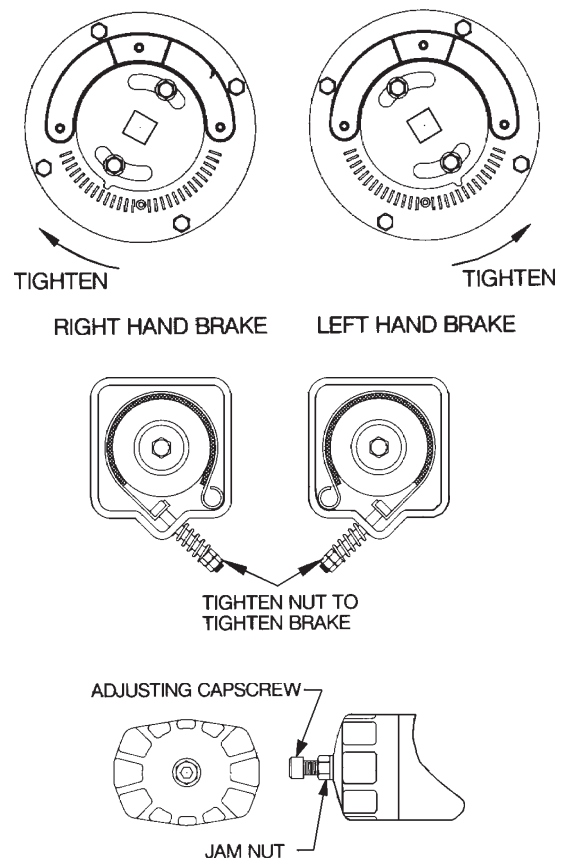

CAUTION DURING REMOVAL! SPRING LOADED COVER!

These brakes require no regular adjustment. To service them, remove two capscrews 180 degrees from each other and install new capscrews which are 1" longer. Slowly, evenly remove the other capscrews until there is no tension on the brake spring. The direction of braking for all multiple disc brakes can be changed by removing the cam clutch, turning it over, and re-installing it. For detailed service instructions, contact your Tulsa Winch distributor or the factory.

M-561 3-10-06-2

TULSA WINCH OPERATING & SAFETY MANUAL

BRAKE ADJUSTMENT

In general, worm brakes on Tulsa winches should only be adjusted enough to hold the load you are currently working with. Over adjustment will result in excessive heat generation and brake wear. The most positive way to insure proper brake adjustment is to lift a test load just barely off the ground. Jog the winch out, and see if the brake holds. If it doesn't, tighten the brake slightly and try it again. If the brake is tightened completely and the load still drifts, the brake must be serviced. DO NOT use the winch to lift loads with a worn brake.

If the input to the winch is accessible and a torque wrench can be put on it, the brake can be set with this torque wrench. The table on the right shows the torque values for all models based on rated linepull.

Model	Brake Torque (Lb.Ft.)
5	3
938	3
1138	3
1000	3
1200	4
10	32
12	32
18	50
18G	50
19	50
23	50
24	70
34	70
64	120
70	140
75	140
80	185

LIMITED WARRANTY

Tulsa Winch expressly warrants its products against defects in material and workmanship under normal and ordinary use and service for a period of One (1) year from the date of purchase from Tulsa Winch or any authorized distributor of Tulsa Winch products. This warranty is not applicable to product failure due to improper operation or usage, misapplication, or employment for other than normal ordinary purposes.

BUYER'S SOLE AND EXCLUSIVE REMEDY IN THE EVENT OF A DEFECT IS EXPRESSLY LIMITED TO THE REPAIR OR REPLACEMENT OF THE PRODUCT, OR THE REFUND OF THE PURCHASE PRICE, AT THE SOLE ELECTION OF TULSA WINCH. Written notice and explanation of the circumstance of any claim that a product has proven defective in material and workmanship should be given promptly by the Buyer to Tulsa Winch. Tulsa Winch requires proof of date of purchase and reserves the right to inspect any product claimed to be defective under this warranty.

EXCEPT AS SPECIFICALLY PROVIDED FOR IN THIS MANUFACTURER'S LIMITED WARRANTY, THERE ARE NO OTHER WARRANTIES EXPRESS OR IMPLIED INCLUDING BUT NOT LIMITED TO ANY IMPLIED WARRANTIES OF MERCHANTABILITY OR FITNESS FOR A PARTICULAR PURPOSE OR USE. IN NO EVENT SHALL TULSA WINCH BE LIABLE FOR LOSS OF PROFITS, INDIRECT, INCIDENTAL, SPECIAL, CONSEQUENTIAL, OR OTHER SIMILAR DAMAGES ARISING OUT OF ANY BREACH OF THIS AGREEMENT, OBLIGATIONS UNDER THE AGREEMENT, NEGLIGENCE OF STRICT LIABILITY. TULSA WINCH MAKES NO WARRANTY, EXPRESS OR IMPLIED, FOR A MINIMUM LENGTH OF SERVICE OR USE OF ANY TULSA WINCH PRODUCT. TULSA WINCH SHALL HAVE NO OBLIGATION TO REPAIR OR REPLACE ITEMS WHICH BY THEIR NATURE ARE EXPENDABLE.

TULSA WINCH · P.O. BOX 471617 · TULSA OKLAHOMA 74147 · PH: 918-663-5744 · FAX: 918-627-3221

M-562 3-10-06-2

MAINTENANCE & SERVICE

GENERAL INFORMATION

Regular maintenance is the key to long equipment life and safe operation. Maintenance requirements have been kept to an absolute minimum. However, it is very important that these maintenance functions be performed as described in this section

DAILY (OR AFTER EVERY ONE HOUR OF WINCH USE)

- Check all bolts and nuts for tightness.
- Replace any missing bolts or nuts with approved replacement parts.
- Check hydraulic system for hydraulic oil leaks. See procedure below.
- Visually inspect the machine for worn parts or cracked welds, and repair as necessary.
- See “Winch Maintenance” in the “Tulsa Winch Operating & Safety Manual”.

WARNING! Escaping fluid under pressure can have sufficient force to penetrate the skin, causing serious personal injury. Fluid escaping from a very small hole can be almost invisible. Use a piece of cardboard or wood, rather than hands to search for suspected leaks.



Keep unprotected body parts, such as face, eyes, and arms as far away as possible from a suspected leak. Flesh injected with hydraulic fluid may develop gangrene or other permanent disabilities.

If injured by injected fluid, see a doctor at once. If your doctor is not familiar with this type of injury, ask him or her to research it immediately to determine proper treatment.

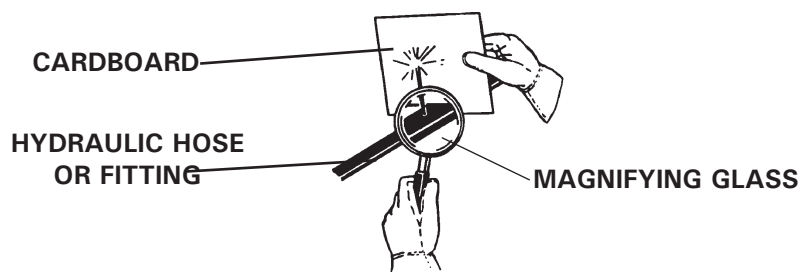

WEEKLY (OR AFTER EVERY 20 HOURS OF OPERATION)

- See “Winch Maintenance” in the “Tulsa Winch Operating & Safety Manual”.

EVERY SIX MONTHS

- See “Winch Maintenance” in the “Tulsa Winch Operating & Safety Manual”.

IMPORTANT: When replacing parts, use only factory approved replacement parts. Manufacturer will not claim responsibility for use of unapproved parts or accessories and/or other damages as a result of their use.

M-1262 3-31-06

STORAGE

GENERAL INFORMATION

The following storage procedure will help you to keep your attachment in top condition. It will also help you get off to a good start the next time your equipment is needed. We therefore strongly recommend that you take the extra time to follow these procedures whenever your attachment will not be used for an extended period of time.

PREPARATION FOR STORAGE

1. Clean the attachment thoroughly, removing all mud, dirt, and grease.
2. Inspect for visible signs of wear, breakage, or damage. Order any parts required, and make the necessary repairs, to avoid delays when starting next season.
3. Tighten all loose nuts, capscrews, and hydraulic connections.
4. Lubricate all grease fittings.
5. Connect the hydraulic couplers together to protect the hydraulic system from contaminants.
6. Touch up all unpainted and exposed areas with paint, to prevent rust.
7. Replace decals, if damaged or in unreadable condition.
8. Store the attachment in a dry and protected place, with a cover, if possible. Leaving the attachment outside will materially shorten its life.

REMOVING FROM STORAGE

1. Remove all protective coverings.
2. Check hydraulic hoses for deterioration, and replace if necessary.

LIMITED WARRANTY

All new Major products are warranted to be free from defects in materials or workmanship which may cause failure under normal usage and service, when used for the purpose intended.

In the event of failure within twelve (12) months from initial retail sale, lease or rental date (excluding cable, ground engaging parts such as sprockets, digging chain, bearings, teeth, tamping and demolition heads, blade cutting edges, pilot bits, auger teeth, auger heads & broom bristles), if after examination, The Major determines failure was due to defective material and/or workmanship, parts will be repaired or replaced. The Major may request defective part or parts be returned prepaid to them for inspection at their place of business at Delhi, Iowa, or to a location specified by The Major.

Any claims under this warranty must be made within fifteen (15) days after the Buyer learns of the facts upon which such claim is based. All claims not made in writing and received by The Major within the time period specified above shall be deemed waived.

THIS WARRANTY IS IN LIEU OF ALL OTHER WARRANTIES EXPRESSED OR IMPLIED, AND THERE ARE NO WARRANTIES OF MERCHANTABILITY OR OF FITNESS FOR A PARTICULAR PURPOSE. IN NO EVENT SHALL THE MAJOR BE LIABLE FOR CONSEQUENTIAL OR SPECIAL DAMAGE.

THE MAJOR'S LIABILITY FOR ANY AND ALL LOSSES AND DAMAGES TO BUYER, RESULTING FROM ANY CAUSE WHATSOEVER, INCLUDING THE MAJOR'S NEGLIGENCE, IRRESPECTIVE OF WHETHER SUCH DEFECTS ARE DISCOVERABLE OR LATENT, SHALL IN NO EVENT EXCEED THE PURCHASE PRICE OF THE PARTICULAR PRODUCTS WITH RESPECT TO WHICH LOSSES OR DAMAGES ARE CLAIMED, OR, AT THE ELECTION OF THE MAJOR, THE REPAIR OR REPLACEMENT OF DEFECTIVE OR DAMAGED PRODUCTS.

PARTS

The following section contains detailed diagrams and parts lists which include your attachment. Please use these diagrams and parts lists to locate replacement parts, prior to contacting the parts department.

When servicing your attachment, remember to use only original manufacturer replacement parts. Substitute parts may not meet the standards required for safe, dependable operation.

To facilitate parts ordering, have the model and serial number of your product ready, to ensure that you receive the correct parts for your specific attachment.

The model and serial number for your attachment should be recorded in the space provided on the cover of this manual. This information may be obtained from the serial number identification plate located on your attachment. **See the parts diagram for your attachment for the location.**

NOTE: Most daily and emergency orders received by 2:00 P.M. will be shipped the same day received, with “Emergency-Machine-Down” orders receiving first priority.



PARTS DEPARTMENT

(563) 922-2981

(800) 922-2981

We Encourage Fax Orders

(563) 922-2593

M-1127 10-4-06-2

3' TRUSS BOOM WITH WINCH

ASSEMBLY #11242

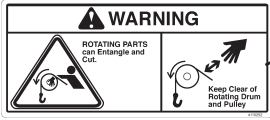

27



28

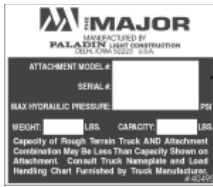

29



30



31

4000 LBS CAP.
(1816 kg CAP.)

26

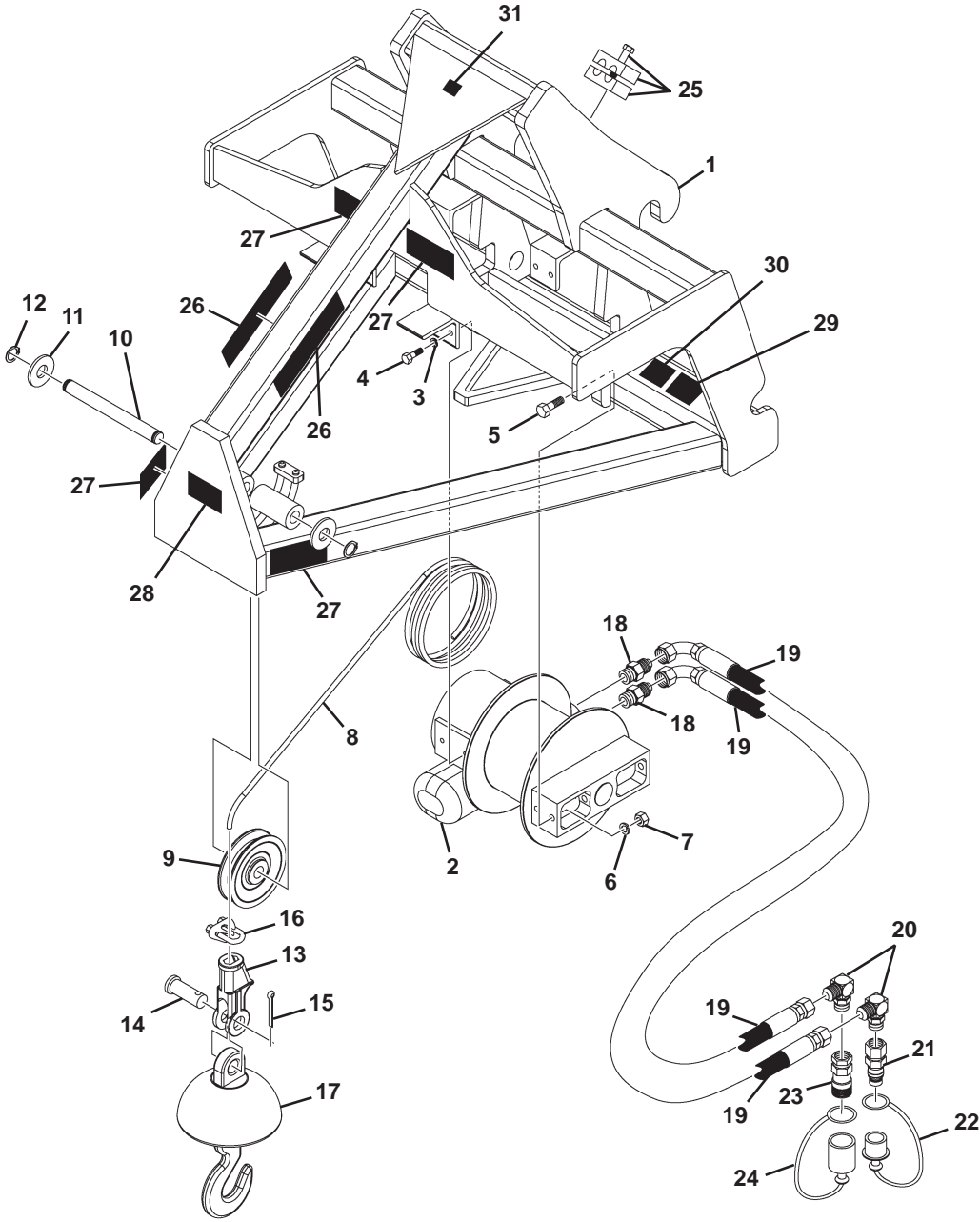

11242

M-526 10-31-05-5

3' TRUSS BOOM WITH WINCH

ASSEMBLY #11242

<u>ITEM</u>	<u>QTY.</u>	<u>PART NO.</u>	<u>DESCRIPTION</u>
1	1	32047	3' Truss Boom Frame
2	1	14434	Truss Boom Winch
3	4	1503	.38" Lock Washer
4	4	1043	.38" UNC x 1.00" Hex Capscrew
5	2	1091	.50" UNC x 1.75" Hex Capscrew
6	2	1505	.50" Lock Washer
7	2	1228	.50" Hex Nut
8	1	14435	Cable
9	1	14436	Pulley
10	1	14437	Pin, 1.00" x 9.32"
11	2	1706	1.00" Hard Flat Washer
12	2	1570	Snap Ring
13	1	14439	Socket Assembly, 3 Ton Wedge. Includes Items 14 & 15
14	1	NSS	Pin
15	1	NSS	Cotter Pin
16	1	14440	Cable Clamp
17	1	14438	Ball Swivel, With Safety Hook
18	2	3457	Straight Adapter 6MBo-6MJ
19	2	37899	Hose Assembly .38" x 32.00" 6FJX-6FJX
20	2	30142	90° Elbow 8MBo-6MJ
21	1	17139	Male Quick Coupler
22	1	51753	Dust Cap
23	1	17140	Female Quick Coupler
24	1	51754	Dust Plug
25	1	81358	Double Clamp
26	2	40603	Capacity Decal
27	4	40602	Rotating Part Danger Decal
28	1	40561	Do Not Tow Warning Decal
29	1	-----	Serial Number Identification Tag Location
30	1	40151	High Pressure Fluid Warning Decal
31	1	4338	Made in USA Decal

NSS-Not Serviced Separately

M-527 10-31-05-6

3' TRUSS BOOM WITH WINCH

ASSEMBLY #12340

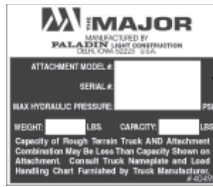
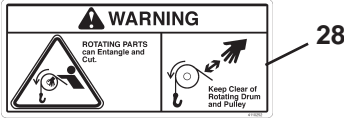

4000 LBS CAP.
(1816 kg CAP.)

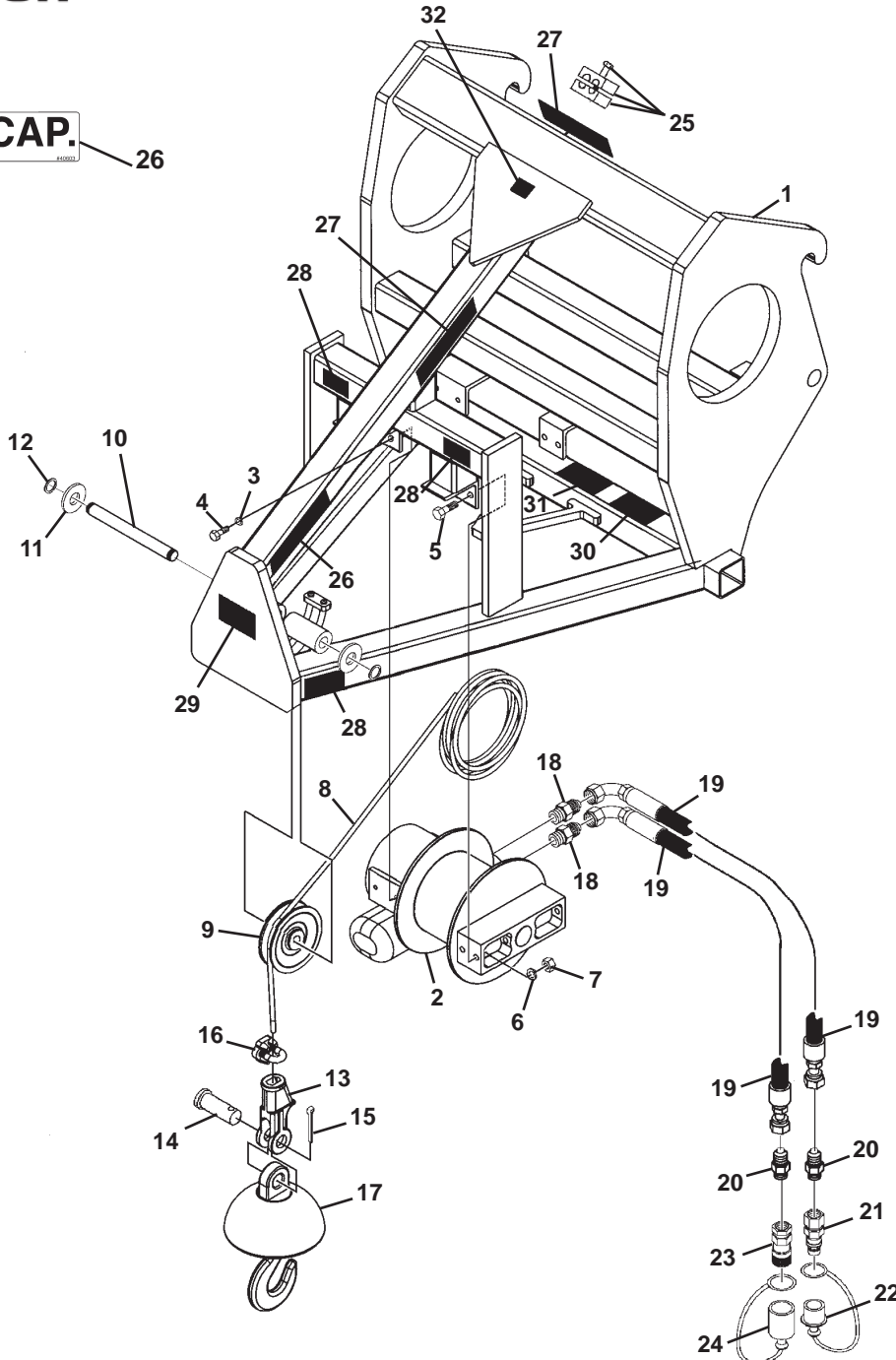

M-1243 3-31-06

3' TRUSS BOOM WITH WINCH

ASSEMBLY #12340

<u>ITEM</u>	<u>QTY.</u>	<u>PART NO.</u>	<u>DESCRIPTION</u>
1	1	305037	3' Truss Boom Frame
2	1	14434	Truss Boom Winch
3	4	1503	.38" Lock Washer
4	4	1043	.38" UNC x 1.00" Hex Capscrew
5	2	1091	.50" UNC x 1.75" Hex Capscrew
6	2	1505	.50" Lock Washer
7	2	1228	.50" UNC Hex Nut
8	1	14435	Cable
9	1	14436	Pulley
10	1	14437	Pin, 1.00" x 9.32"
11	2	1706	1.00" Hard Flat Washer
12	2	1570	Snap Ring
13	1	14439	Socket Assembly, 3 Ton Wedge. Includes Items 14 & 15
14	1	NSS	Pin
15	1	NSS	Cotter Pin
16	1	14440	Cable Clamp
17	1	14438	Ball Swivel, With Safety Hook
18	2	3457	Straight Adapter 6MBo-6MJ
19	2	37852	Hose Assembly .38" x 39.00" 6FJX-6FJX 90°
20	2	3269	Straight Connector 8MBo-6MJ
21	1	84923	Male Quick Coupler
22	1	32549	Dust Cap
23	1	84928	Female Quick Coupler
24	1	32548	Dust Plug
25	1	81358	Double Clamp
26	2	40603	Capacity Decal
27	3	40502	Major Logo, Medium
28	4	40602	Rotating Part Warning Decal
29	1	40561	Do Not Tow Warning Decal
30	1	-----	Serial Number Identification Tag Location
31	1	40151	High Pressure Fluid Warning Decal
32	1	4338	Made in USA Decal

NSS-Not Serviced Separately

M-1244 3-31-06

3' TRUSS BOOM WITH WINCH

ASSEMBLY #12722

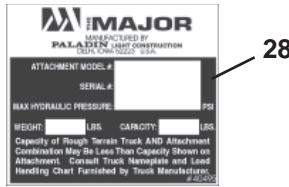
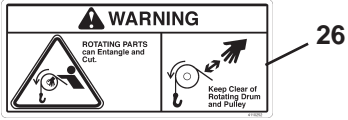

4000 LBS CAP.
(1816 kg CAP.)

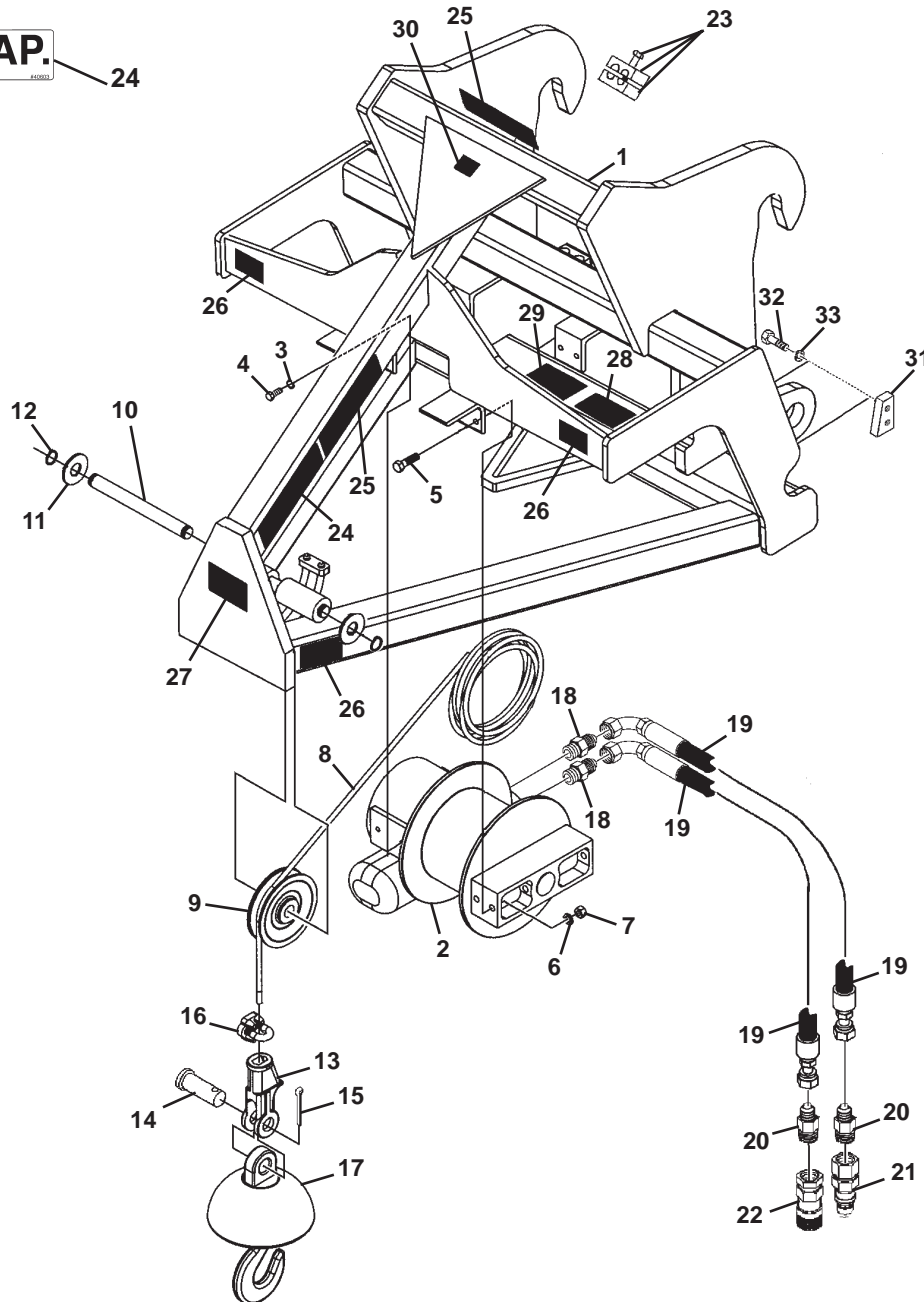

M-1247 3-31-06

3' TRUSS BOOM WITH WINCH

ASSEMBLY #12722

<u>ITEM</u>	<u>QTY.</u>	<u>PART NO.</u>	<u>DESCRIPTION</u>
1	1	103185	3' Truss Boom Frame
2	1	14434	Truss Boom Winch
3	4	1503	.38" Lock Washer
4	4	1043	.38" UNC x 1.00" Hex Capscrew
5	2	1091	.50" UNC x 1.75" Hex Capscrew
6	2	1505	.50" Lock Washer
7	2	1228	.50" UNC Hex Nut
8	1	14435	Cable
9	1	14436	Pulley
10	1	14437	Pin, 1.00" x 9.32"
11	2	1706	1.00" Hard Flat Washer
12	2	1570	Snap Ring
13	1	14439	Socket Assembly, 3 Ton Wedge. Includes Items 14 & 15
14	1	NSS	Pin
15	1	NSS	Cotter Pin
16	1	14440	Cable Clamp
17	1	14438	Ball Swivel, With Safety Hook
18	2	3457	Straight Adapter 6MBo-6MJ
19	2	37810	Hose Assembly .38" x 68.00" 6FJX-6FJX 90°
20	2	30201	Straight Connector 12MBo-6MJ
21	1	22519	Male Quick Coupler
22	1	22518	Female Quick Coupler
23	1	81358	Double Clamp
24	2	40603	Capacity Decal
25	3	40502	Major Logo, Medium
26	4	40602	Rotating Part Warning Decal
27	1	40561	Do Not Tow Warning Decal
28	1	----	Serial Number Identification Tag Location
29	1	40151	High Pressure Fluid Warning Decal
30	1	4338	Made in USA Decal
31	2	14228	Stop Block
32	4	10012	.75" UNC x 2.25" Hex Capscrew, Grade 8
33	4	1507	.75" Lock Washer

M-1248 3-31-06

3' TRUSS BOOM WITH WINCH

ASSEMBLY #12637

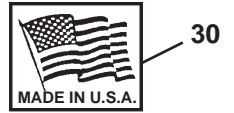
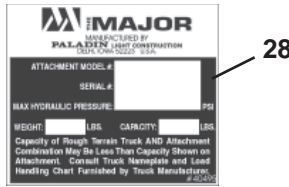
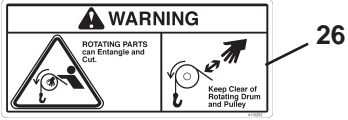

4000 LBS CAP.
(1816 kg CAP.)

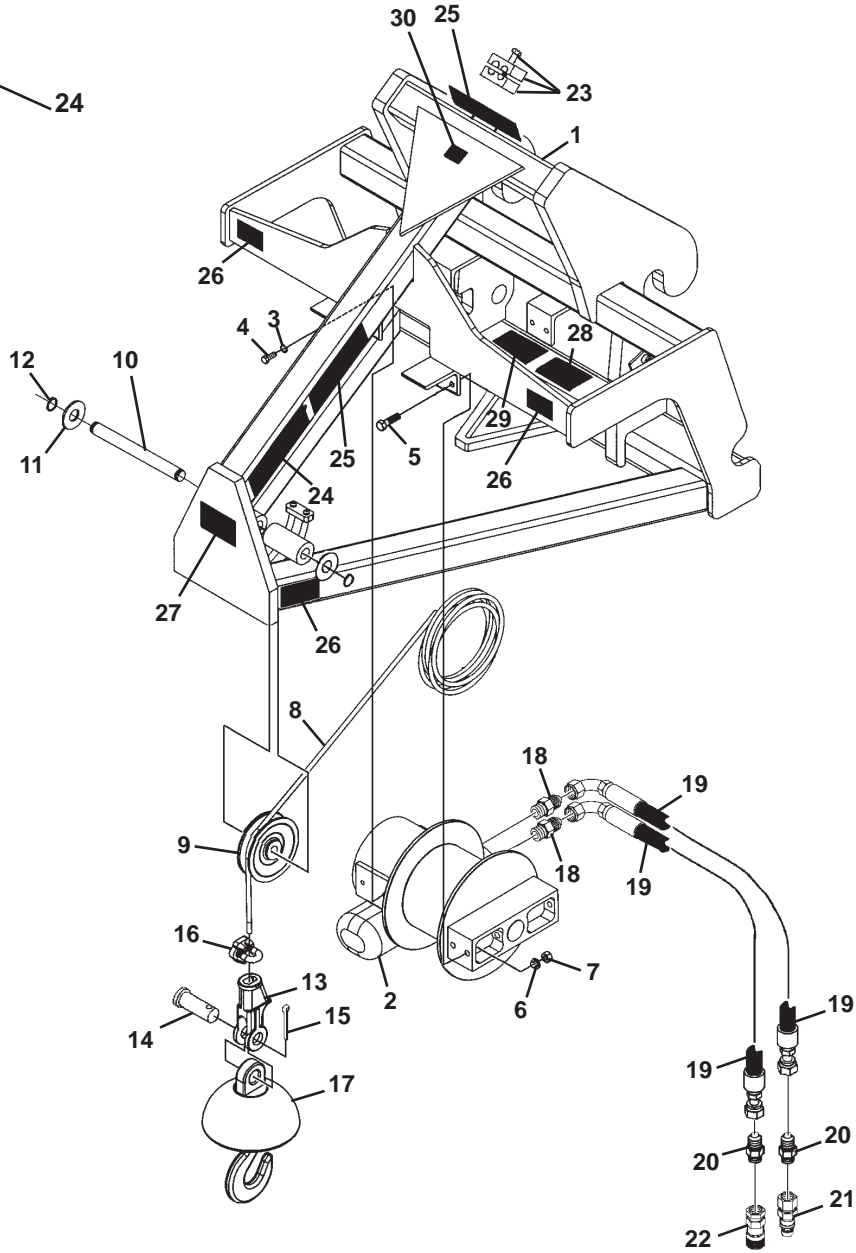

3' TRUSS BOOM WITH WINCH

ASSEMBLY #12637

<u>ITEM</u>	<u>QTY.</u>	<u>PART NO.</u>	<u>DESCRIPTION</u>
1	1	100721	3' Truss Boom Frame
2	1	14434	Truss Boom Winch
3	4	1503	.38" Lock Washer
4	4	1043	.38" UNC x 1.00" Hex Capscrew
5	2	1091	.50" UNC x 1.75" Hex Capscrew
6	2	1505	.50" Lock Washer
7	2	1228	.50" UNC Hex Nut
8	1	14435	Cable
9	1	14436	Pulley
10	1	14437	Pin, 1.00" x 9.32"
11	2	1706	1.00" Hard Flat Washer
12	2	1570	Snap Ring
13	1	14439	Socket Assembly, 3 Ton Wedge. Includes Items 14 & 15
14	1	NSS	Pin
15	1	NSS	Cotter Pin
16	1	14440	Cable Clamp
17	1	14438	Ball Swivel, With Safety Hook
18	2	3457	Straight Adapter 6MBo-6MJ
19	2	37801	Hose Assembly .38" x 70.00" 6FJX-6FJX 90°, HS
20	2	3269	Straight Connector 8MBo-6MJ
21	1	14176	Male Quick Coupler
22	1	14175	Female Quick Coupler
23	1	81358	Double Clamp
24	2	40603	Capacity Decal
25	3	40502	Major Logo, Medium
26	4	40602	Rotating Part Warning Decal
27	1	40561	Do Not Tow Warning Decal
28	1	----	Serial Number Identification Tag Location
29	1	40151	High Pressure Fluid Warning Decal
30	1	4338	Made in USA Decal

3' TRUSS BOOM WITH WINCH

ASSEMBLY #12767

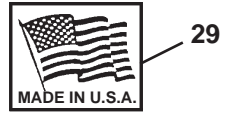
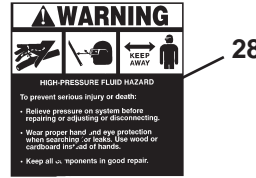
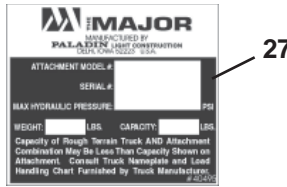
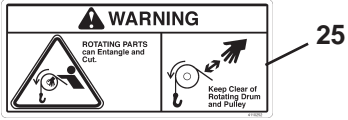

4000 LBS CAP.
(1816 kg CAP.)

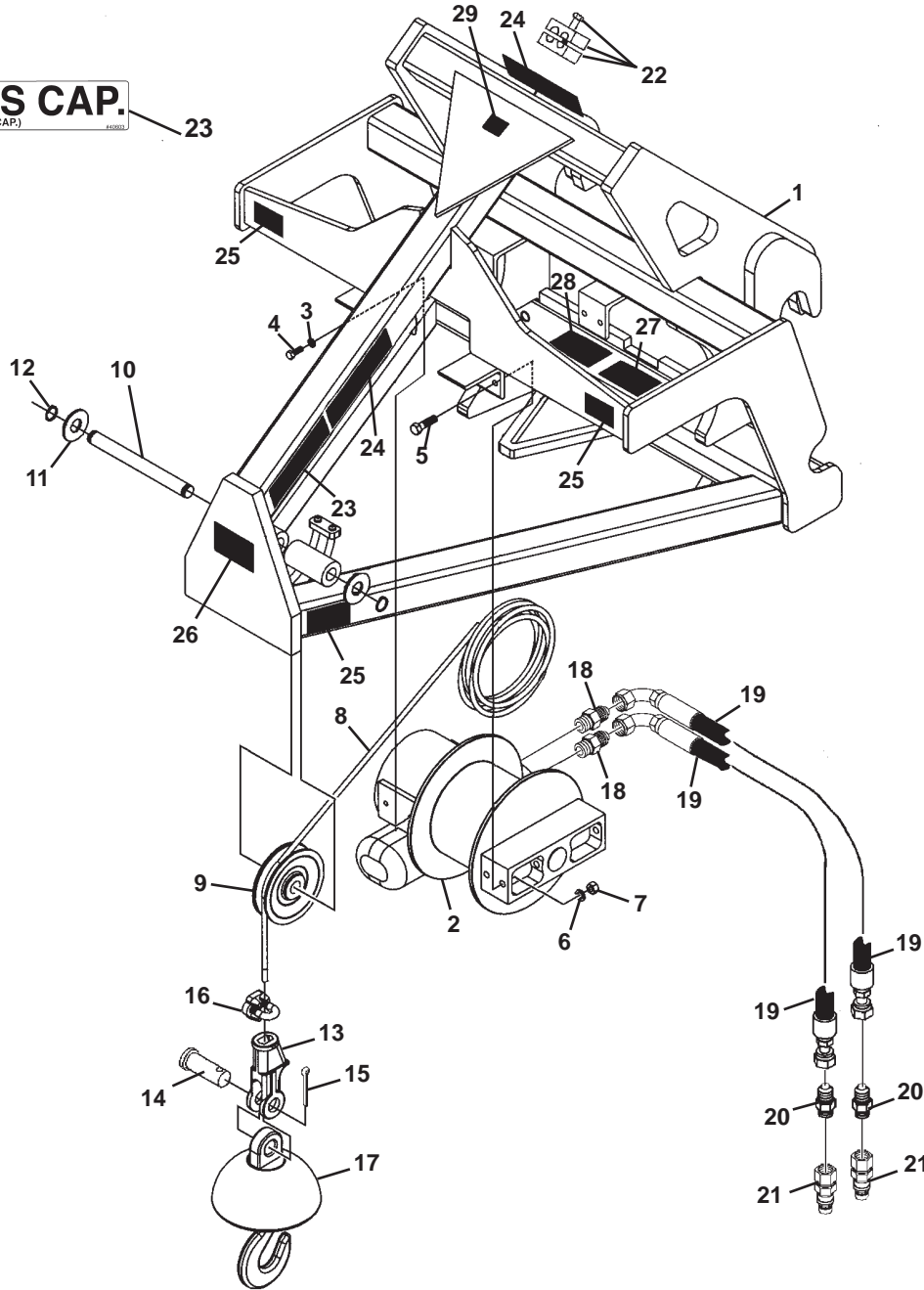

3' TRUSS BOOM WITH WINCH

ASSEMBLY #12767

<u>ITEM</u>	<u>QTY.</u>	<u>PART NO.</u>	<u>DESCRIPTION</u>
1	1	103456	3' Truss Boom Frame
2	1	14434	Truss Boom Winch
3	4	1503	.38" Lock Washer
4	4	1043	.38" UNC x 1.00" Hex Capscrew
5	2	1091	.50" UNC x 1.75" Hex Capscrew
6	2	1505	.50" Lock Washer
7	2	1228	.50" UNC Hex Nut
8	1	14435	Cable
9	1	14436	Pulley
10	1	14437	Pin, 1.00" x 9.32"
11	2	1706	1.00" Hard Flat Washer
12	2	1570	Snap Ring
13	1	14439	Socket Assembly, 3 Ton Wedge. Includes Items 14 & 15
14	1	NSS	Pin
15	1	NSS	Cotter Pin
16	1	14440	Cable Clamp
17	1	14438	Ball Swivel, With Safety Hook
18	2	3457	Straight Adapter 6MBo-6MJ
19	2	37961	Hose Assembly .38" x 93.00" 6FJX-6FJX 90°, HS
20	2	3269	Straight Connector 8MBo-6MJ
21	2	17139	Male Quick Coupler
22	1	81358	Double Clamp
23	2	40603	Capacity Decal
24	3	40502	Major Logo, Medium
25	4	40602	Rotating Part Warning Decal
26	1	40561	Do Not Tow Warning Decal
27	1	-----	Serial Number Identification Tag Location
28	1	40151	High Pressure Fluid Warning Decal
29	1	4338	Made in USA Decal

NSS-Not Serviced Separately

3' TRUSS BOOM WITH WINCH

ASSEMBLY #12886

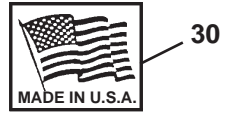
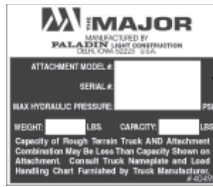
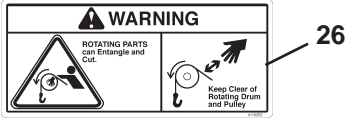

4000 LBS CAP.
(1816 kg CAP.)

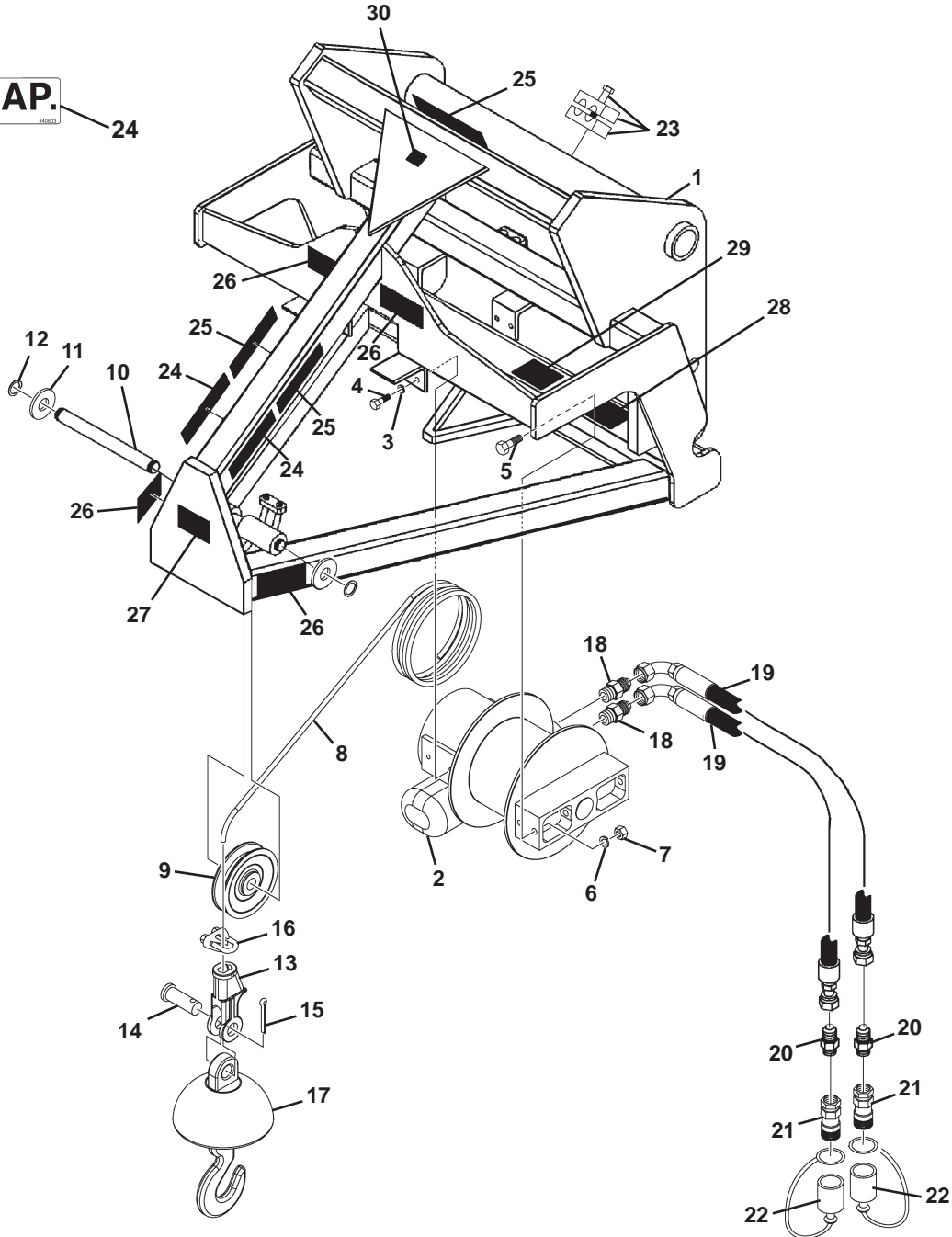

11242

M-1224 2-21-06

3' TRUSS BOOM WITH WINCH

ASSEMBLY #12886

<u>ITEM</u>	<u>QTY.</u>	<u>PART NO.</u>	<u>DESCRIPTION</u>
1	1	106249	3' Truss Boom Frame
2	1	14434	Truss Boom Winch
3	4	1503	.38" Lock Washer
4	4	1043	.38" UNC x 1.00" Hex Capscrew
5	2	1091	.50" UNC x 1.75" Hex Capscrew
6	2	1505	.50" Lock Washer
7	2	1228	.50" Hex Nut
8	1	14435	Cable
9	1	14436	Pulley
10	1	14437	Pin, 1.00" x 9.32"
11	2	1706	1.00" Hard Flat Washer
12	2	1570	Snap Ring
13	1	14439	Socket Assembly, 3 Ton Wedge. Includes Items 14 & 15
14	1	NSS	Pin
15	1	NSS	Cotter Pin
16	1	14440	Cable Clamp
17	1	14438	Ball Swivel, With Safety Hook
18	2	3457	Straight Adapter 6MBo-6MJ
19	2	38085	Hose Assembly .38" x 87.00" 6FJX-6FJX90°
20	2	3269	Straight Connector 8MBo-6MJ
21	2	84928	Female Quick Coupler
22	2	32548	Dust Plug
23	1	81358	Double Clamp
24	2	40603	Capacity Decal
25	3	40502	Major Logo, Medium
26	4	40602	Rotating Part Danger Decal
27	1	40561	Do Not Tow Warning Decal
28	1	----	Serial Number Identification Tag Location
29	1	40151	High Pressure Fluid Warning Decal
30	1	4338	Made in USA Decal

NSS-Not Serviced Separately

M-1225 2-21-06

12' TRUSS BOOM WITH WINCH

ASSEMBLY #11141

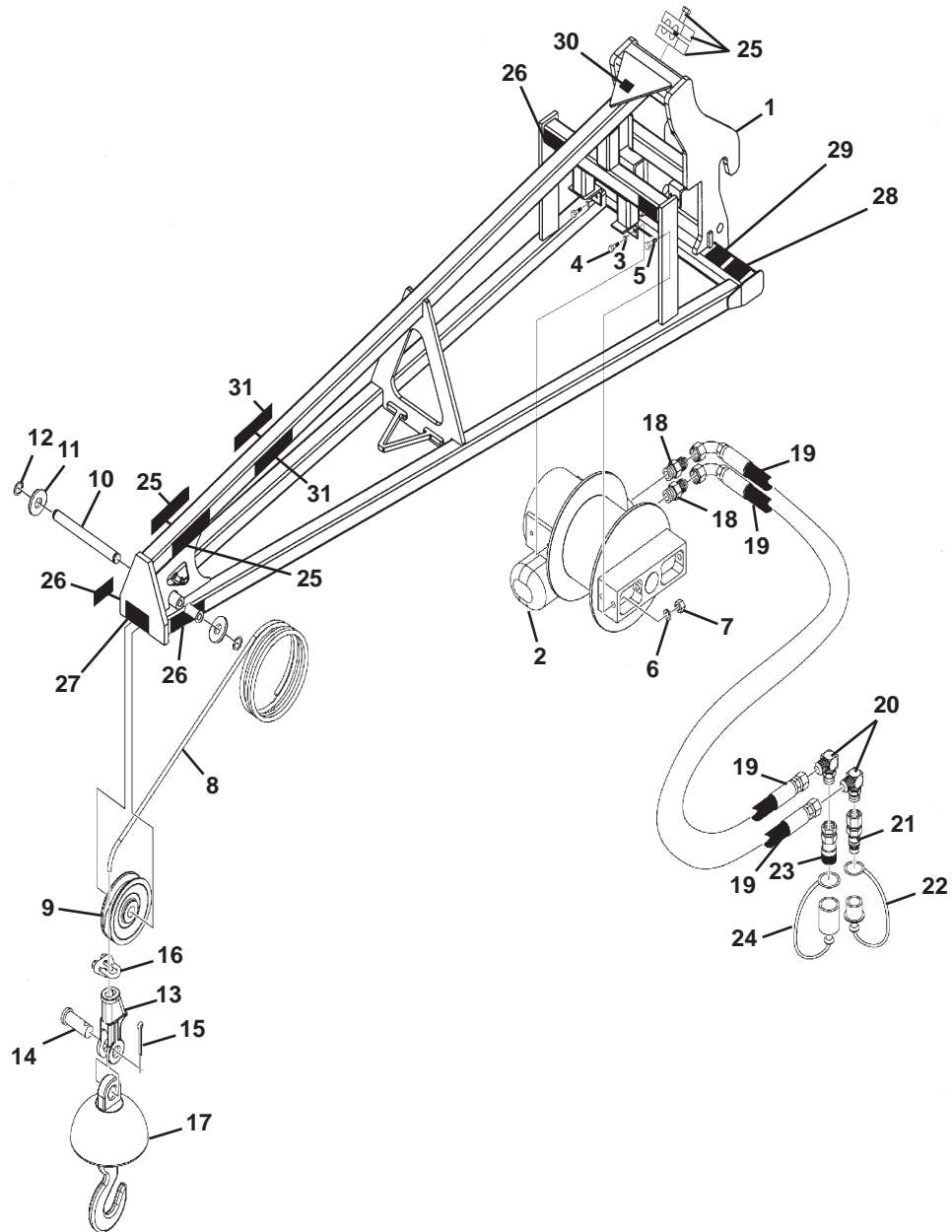
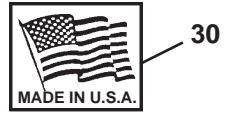
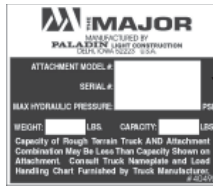
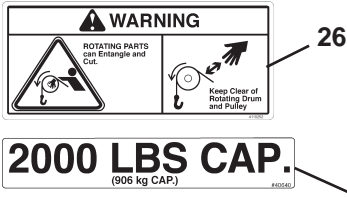

12' TRUSS BOOM WITH WINCH

ASSEMBLY #11141

<u>ITEM</u>	<u>QTY.</u>	<u>PART NO.</u>	<u>DESCRIPTION</u>
1	1	101664	12' Truss Boom Frame
2	1	14434	Truss Boom Winch
3	4	1503	.38" Lock Washer
4	4	1043	.38" UNC x 1.00" Hex Capscrew
5	2	1091	.50" UNC x 1.75" Hex Capscrew
6	2	1505	.50" Lock Washer
7	2	1228	.50" Hex Nut
8	1	14435	Cable With Swage Plug
9	1	14436	Pulley
10	1	14437	Pin, 1.00" x 9.32"
11	2	1706	1.00" Flat Hard Washer
12	2	1570	Snap Ring
13	1	14439	Socket Assembly, 3 Ton Wedge Includes Items 14 & 15
14	1	NSS	Pin
15	1	NSS	Cotter Pin
16	1	14440	Cable Clamp
17	1	14438	Ball Swivel, With Safety Hook
18	2	3457	Straight Adapter 6MBo-6MJ
19	2	37899	Hose Assembly .38" x 32.00" 6FJX-6FJX
20	2	30142	90° Elbow 8MBo-6MJ
21	1	17139	Male Quick Coupler
22	1	51753	Dust Cap
23	1	17140	Female Quick Coupler
24	1	51754	Dust Plug
25	2	40640	Capacity Decal
26	4	40602	Rotating Part Danger Decal
27	1	40561	Do Not Tow Warning Decal
28	1	-----	Serial Number Identification Tag Location
29	1	40151	High Pressure Fluid Warning Decal
30	1	4338	Made in USA Decal
31	2	40502	Major Logo, Medium

M-1126 11-16-05

12' TRUSS BOOM WITH WINCH

ASSEMBLY #11147

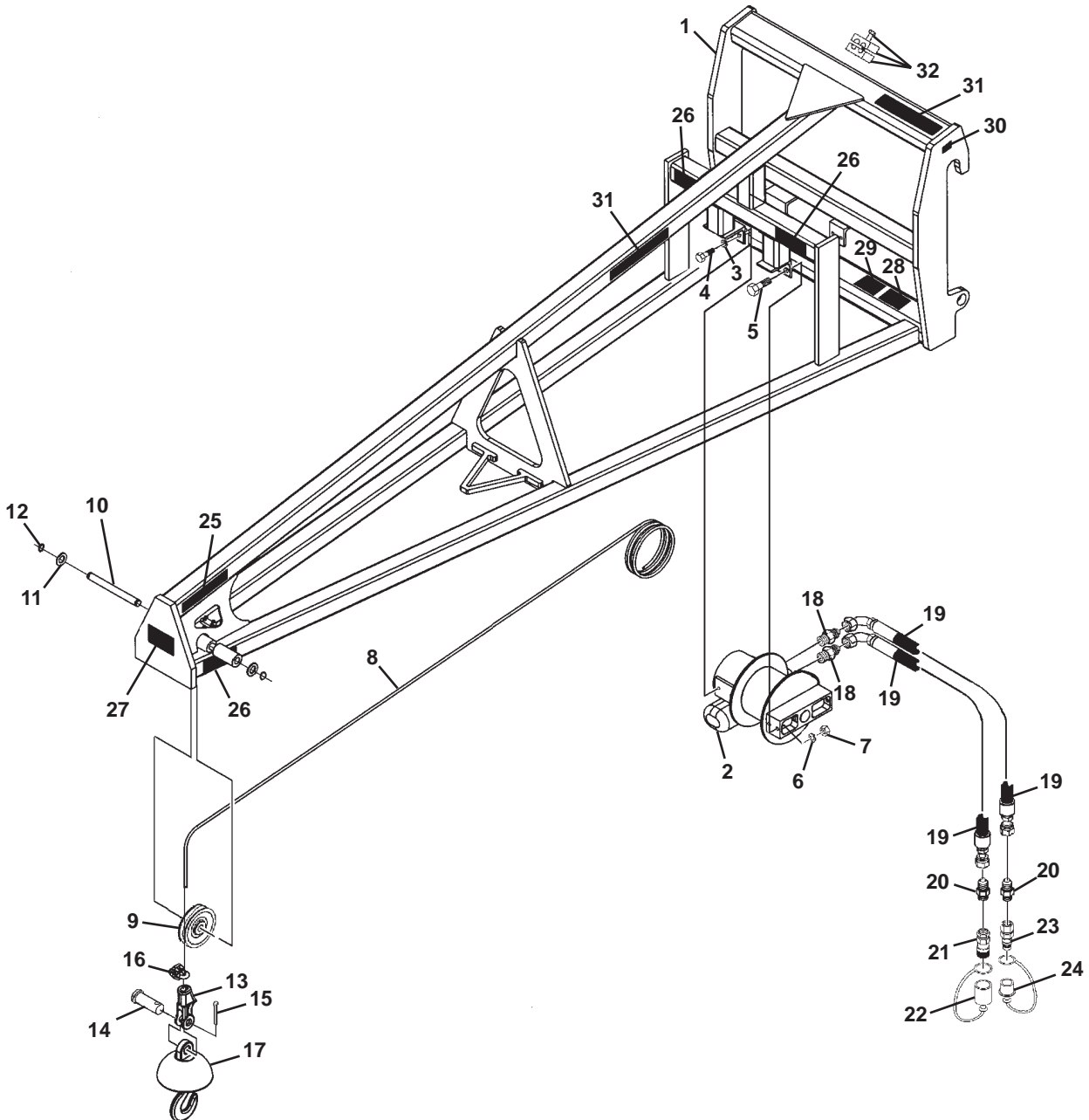
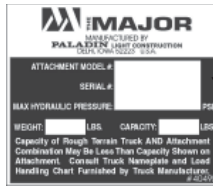
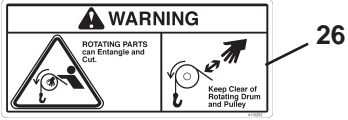

M-1255 3-31-06

12' TRUSS BOOM WITH WINCH

ASSEMBLY #11147

<u>ITEM</u>	<u>QTY.</u>	<u>PART NO.</u>	<u>DESCRIPTION</u>
1	1	16801	12' Truss Boom Frame
2	1	14434	Truss Boom Winch
3	4	1503	.38" Lock Washer
4	4	1043	.38" UNC x 1.00" Hex Capscrew
5	2	1091	.50" UNC x 1.75" Hex Capscrew
6	2	1505	.50" Lock Washer
7	2	1228	.50" UNC Hex Nut
8	1	14435	Cable
9	1	14436	Pulley
10	1	14437	Pin, 1.00" x 9.32"
11	2	1706	1.00" Hard Flat Washer
12	2	1570	Snap Ring
13	1	14439	Socket Assembly, 3 Ton Wedge Includes Items 14 & 15
14	1	NSS	Pin
15	1	NSS	Cotter Pin
16	1	14440	Cable Clamp
17	1	14438	Ball Swivel, With Safety Hook
18	2	3457	Straight Adapter 6MBo-6MJ
19	2	37810	Hose Assembly .38" x 68.00" 6FJX-6FJX 90°
20	2	3269	Straight Connector 8MBo-6MJ
21	1	84928	Female Quick Coupler
22	1	32548	Dust Plug
23	1	84923	Male Quick Coupler
24	1	32549	Dust Cap
25	2	40640	Capacity Decal
26	4	40602	Rotating Part Warning Decal
27	1	40561	Do Not Tow Warning Decal
28	1	----	Serial Number Identification Tag Location
29	1	40151	High Pressure Fluid Warning Decal
30	1	4338	Made in USA Decal
31	3	40502	Major Logo, Medium
32	1	81358	Double Clamp

M-1256 3-31-06

12' TRUSS BOOM WITH WINCH

ASSEMBLY #12514

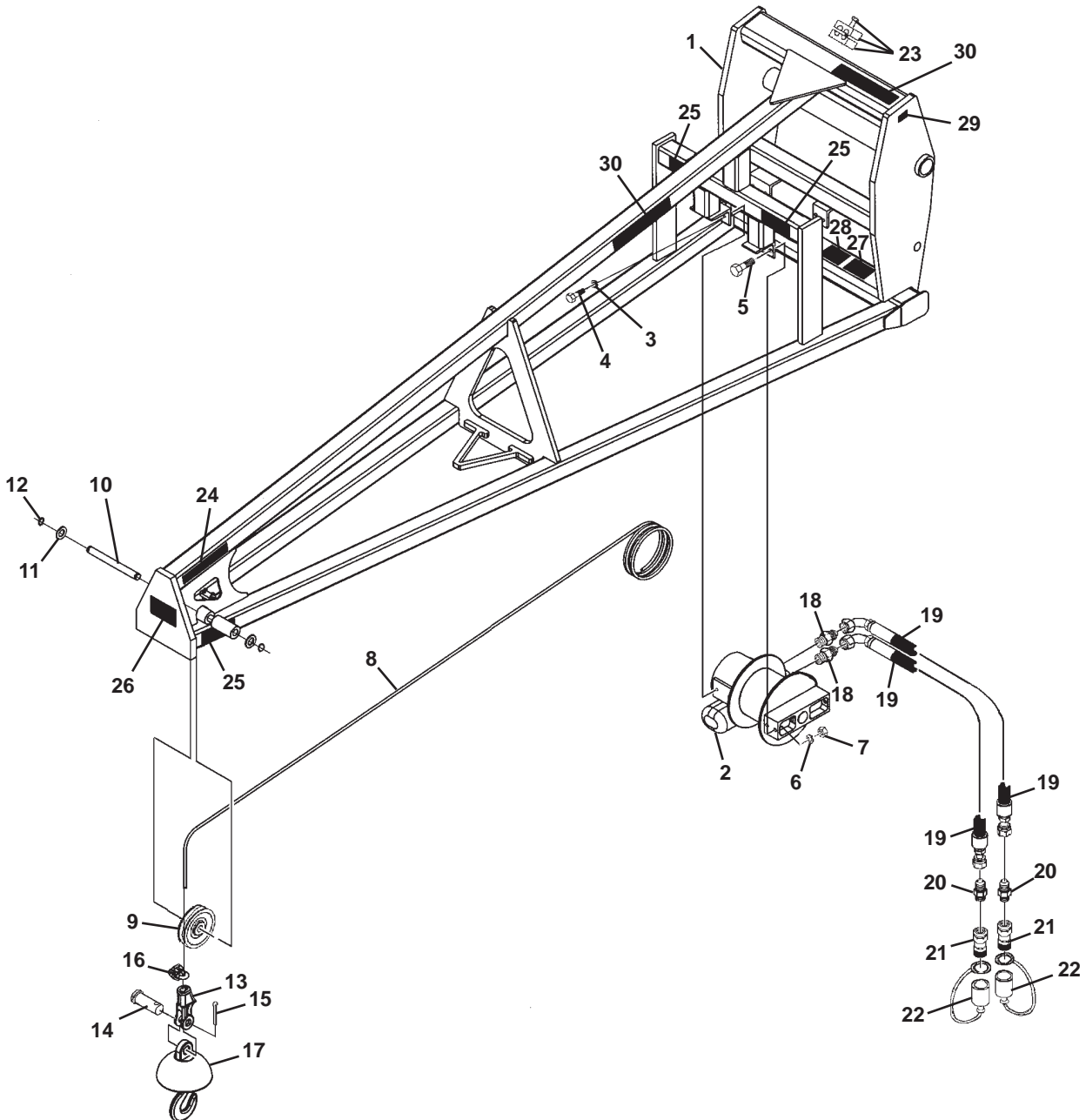
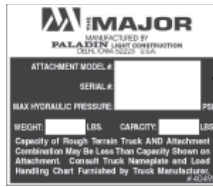
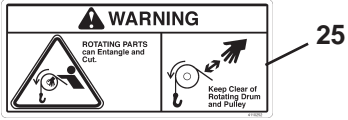

M-1251 4-4-06

12' TRUSS BOOM WITH WINCH

ASSEMBLY #12514

<u>ITEM</u>	<u>QTY.</u>	<u>PART NO.</u>	<u>DESCRIPTION</u>
1	1	18258	12' Truss Boom Frame
2	1	14434	Truss Boom Winch
3	4	1503	.38" Lock Washer
4	4	1043	.38" UNC x 1.00" Hex Capscrew
5	2	1091	.50" UNC x 1.75" Hex Capscrew
6	2	1505	.50" Lock Washer
7	2	1228	.50" UNC Hex Nut
8	1	14435	Cable
9	1	14436	Pulley
10	1	14437	Pin, 1.00" x 9.32"
11	2	1706	1.00" Hard Flat Washer
12	2	1570	Snap Ring
13	1	14439	Socket Assembly, 3 Ton Wedge Includes Items 14 & 15
14	1	NSS	Pin
15	1	NSS	Cotter Pin
16	1	14440	Cable Clamp
17	1	14438	Ball Swivel, With Safety Hook
18	2	3457	Straight Connector 6MBo-6MJ
19	2	38085	Hose Assembly .38" x 87.00" 6FJX-6FJX90°
20	2	3269	Straight Connector 8MBo-6MJ
21	2	84928	Female Quick Coupler
22	2	32548	Dust Plug
23	1	81358	Double Clamp
24	2	40640	Capacity Decal
25	4	40602	Rotating Part Warning Decal
26	1	40561	Do Not Tow Warning Decal
27	1	-----	Serial Number Identification Tag Location
28	1	40151	High Pressure Fluid Warning Decal
29	1	4338	Made in USA Decal
30	3	40502	Major Logo, Medium

NSS-Not Serviced Separately

12' TRUSS BOOM WITH WINCH

ASSEMBLY #12746

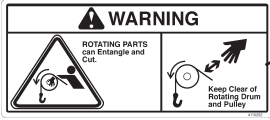

24



25

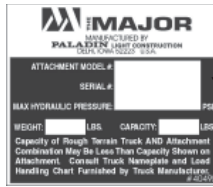

26



27



30

2000 LBS CAP.
(906 kg CAP.) #12746

23

28

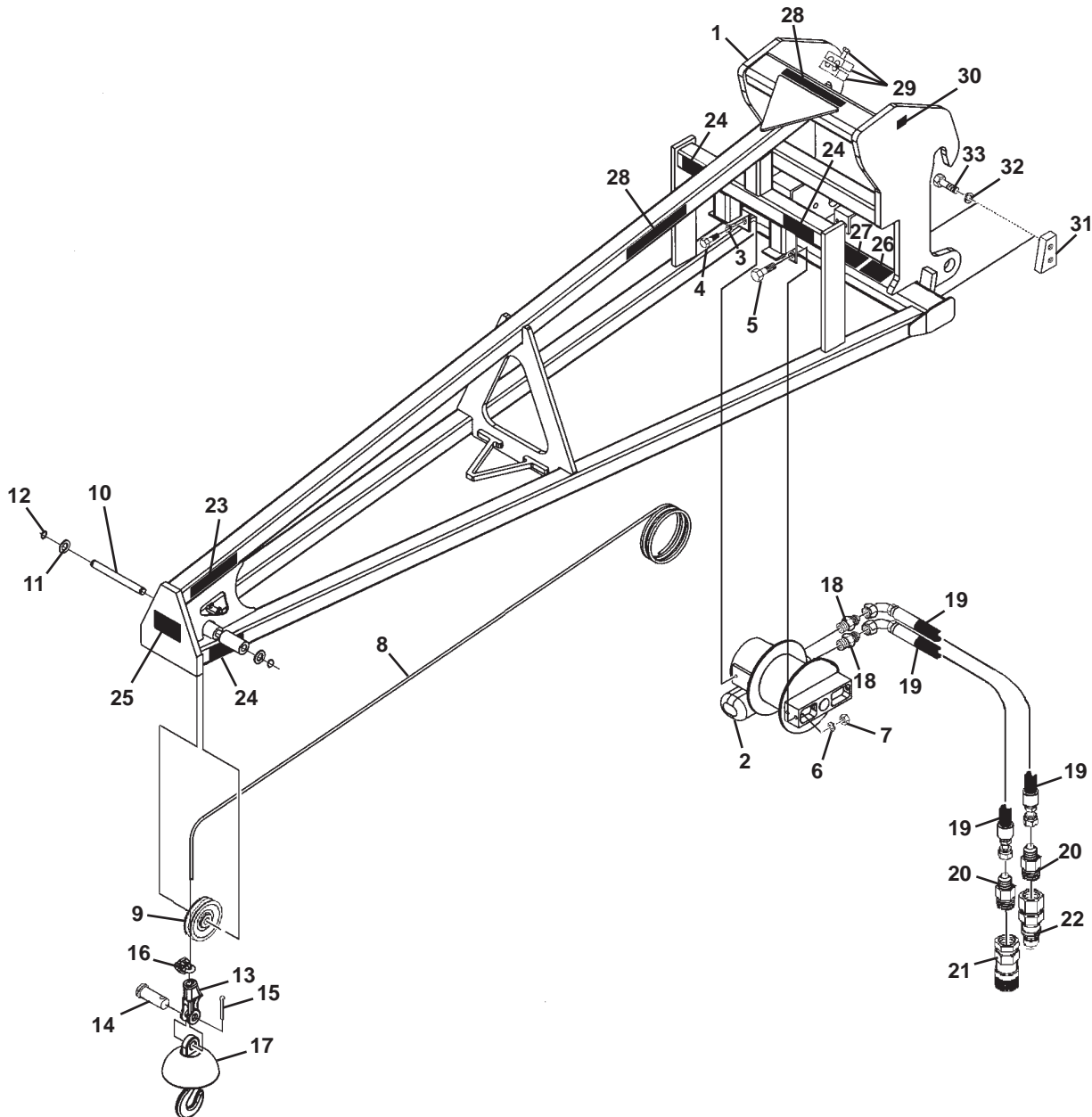

M-1257 3-31-06

12' TRUSS BOOM WITH WINCH

ASSEMBLY #12746

<u>ITEM</u>	<u>QTY.</u>	<u>PART NO.</u>	<u>DESCRIPTION</u>
1	1	102906	12' Truss Boom Frame
2	1	14434	Truss Boom Winch
3	4	1503	.38" Lock Washer
4	4	1043	.38" UNC x 1.00" Hex Capscrew
5	2	1091	.50" UNC x 1.75" Hex Capscrew
6	2	1505	.50" Lock Washer
7	2	1228	.50" UNC Hex Nut
8	1	14435	Cable
9	1	14436	Pulley
10	1	14437	Pin, 1.00" x 9.32"
11	2	1706	1.00" Hard Flat Washer
12	2	1570	Snap Ring
13	1	14439	Socket Assembly, 3 Ton Wedge Includes Items 14 & 15
14	1	NSS	Pin
15	1	NSS	Cotter Pin
16	1	14440	Cable Clamp
17	1	14438	Ball Swivel, With Safety Hook
18	2	3457	Straight Adapter 6MBo-6MJ
19	2	37810	Hose Assembly .38" x 68.00" 6FJX-6FJX 90°
20	2	30201	Straight Connector 12MBo-6MJ
21	1	22518	Female Quick Coupler
22	1	22519	Male Quick Coupler
23	2	40640	Capacity Decal
24	4	40602	Rotating Part Warning Decal
25	1	40561	Do Not Tow Warning Decal
26	1	-----	Serial Number Identification Tag Location
27	1	40151	High Pressure Fluid Warning Decal
28	3	40502	Major Logo, Medium
29	1	81358	Double Clamp
30	1	4338	Made in USA Decal
31	2	14228	Stop Block
32	4	1507	.75" Lock Washer
33	4	10012	.75" UNC x 2.25" Hex Capscrew, Grade 8

M-1258 3-31-06



**P.O. Box 266
Delhi, IA 52223-0266**

**(563) 922-2981
(800) 922-2981**

www.paladinbrands.com

M-1360 10-4-06