



SERVICE PARTS LIST

BULLETIN NO.
54-46-0410

SPECIFY CATALOG NO. AND SERIAL NO. WHEN ORDERING PARTS		REVISED BULLETIN	DATE
M18™ FUEL™ 1-1/2" Magnetic Drill			July 2015
CATALOG NO. 2787-20	STARTING SERIAL NUMBER	WIRING INSTRUCTION	
	G56A	See pages 4 and 5	

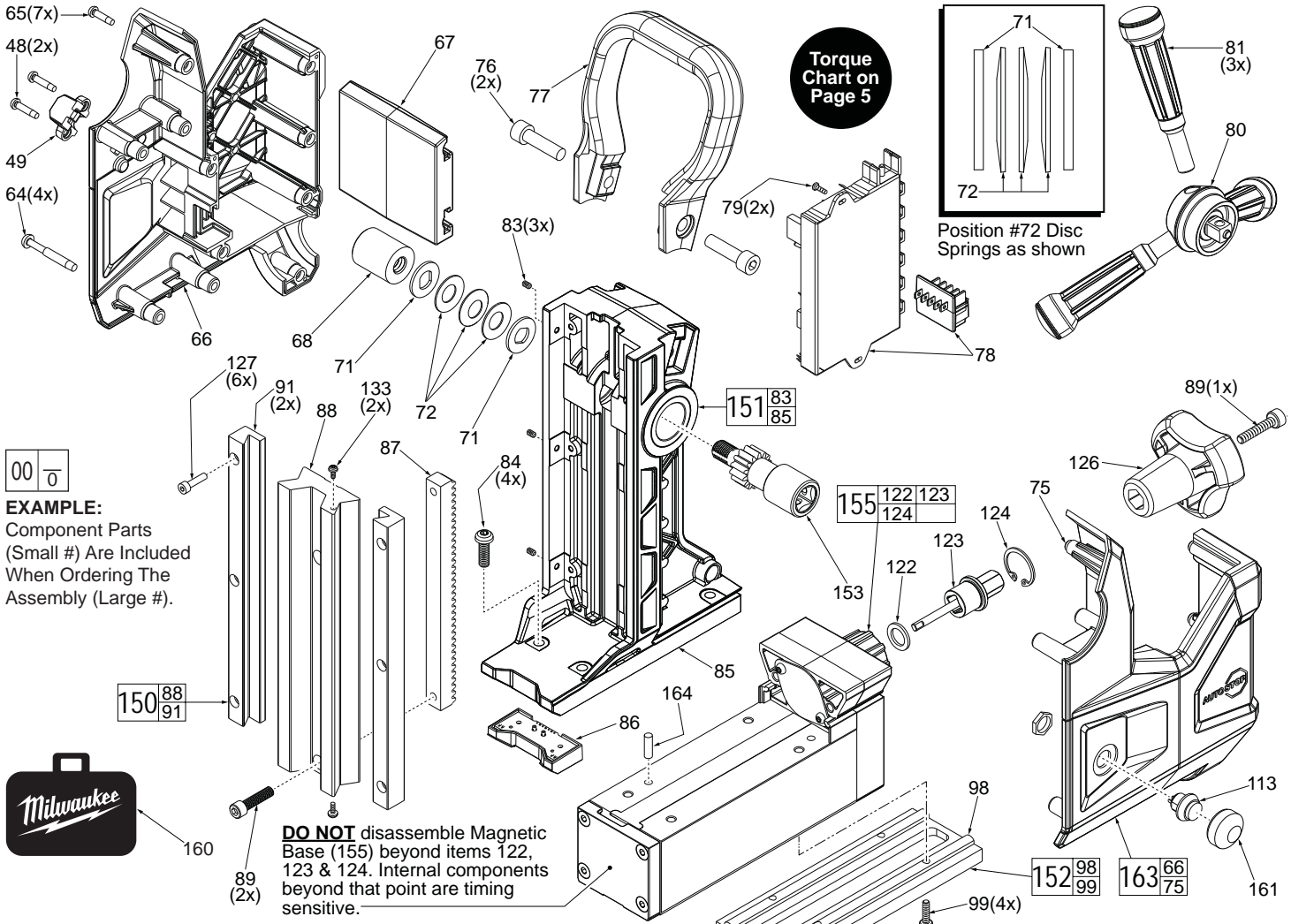

FIG.	PART NO.	DESCRIPTION OF PART	NO. REQ.
48	06-82-3006	M4 x 18mm Pan Hd. T-20 Screw	(2)
49	31-17-0035	Cable Clamp (Same as on drill motor)	(1)
64	06-82-0009	M5 x 1.5mm Pan Hd. T-25 Screw	(4)
65	06-82-0011	M4 x .625 Pan Hd. T-25 Screw	(7)
66	-----	Housing Cover	(1)
67	44-52-0051	Battery Pad	(1)
68	43-12-0055	Handle Square Driver	(1)
71	45-88-0028	Washer	(2)
72	40-50-0029	Disc Spring	(3)
75	-----	Housing Support	(1)
76	05-74-0014	M8 x 1.125, 6mm Hex Socket Hd. Cap Scr	(2)
77	43-62-0017	Carrying Handle	(1)
78	22-09-0022	PCBA/Battery Connector Block Assembly	(1)
79	05-83-0010	M2.5 x 7/32" Round Hd. Phillips Screw	(2)
80	43-78-0032	Quick Connect Hub Assembly	(1)
81	43-62-0022	Feed Handle	(3)
83	06-83-0015	2mm Hex Set Screw	(3)
84	05-81-2787	1/4-20 x 1", 4.5mm Hex Button Hd. Screw	(4)
85	-----	Magstand Base with Bushings	(1)
86	22-09-0042	Lower Control Board with LED	(1)
87	44-80-0061	Rack	(1)
88	-----	Dovetail	(1)
89	06-75-3050	1/4-20 x 3/4", 3/16" Hex Socket Hd. Screw	(3)
91	-----	Dovetail Rail	(2)
98	-----	Insert Adapter	(1)
99	-----	8-32 Screw	(4)
113	23-66-0017	LED Switch Assembly	(1)

FIG.	PART NO.	DESCRIPTION OF PART	NO. REQ.
122	45-88-0039	Rubber Washer	(1)
123	45-08-0018	Spindle Lock Shaft	(1)
124	44-86-0032	Retaining Ring	(1)
126	43-98-0047	Magnet Control Knob	(1)
127	05-74-0013	3mm Hex Socket Hd. Cap Screw	(6)
133	05-80-2787	M3 Flat Head Machine Screw	(2)
150	44-81-0070	Dovetail and Rail Kit	(1)
151	42-20-0015	Magstand Base Assembly	(1)
152	48-10-0130	Pipe Adapter Insert Kit (Accessory)	(1)
153	36-18-0030	Rack/Gear Shaft Assembly	(1)
155	42-20-2787	Magnetic Base/Rear Gearcase Assembly	(1)
160	42-55-0055	Blow Molded Carrying Case	(1)
161	22-68-0020	Rubber Switch Cover	(1)
163	43-76-2787	Housing Assembly	(1)
164	44-60-0002	Alignment Pin	(1)
	45-56-0017	Safety Strap (Not Shown)	(1)
	12-20-0057	Service Nameplate (Not Shown)	(1)
	10-20-0503	Warning Label (Not Shown)	(1)
	10-20-0614	Knob Label (Not Shown)	(1)
	10-20-0616	Permanent Magnet Label (Not Shown)	(1)

Torque Chart on Page 5

SERVICE FIXTURES:
 61-30-2787 Rotor Press Fixture
 61-30-2788 Spindle Bushing Press Fixture
 61-30-2789 Rotor Removal Fixture

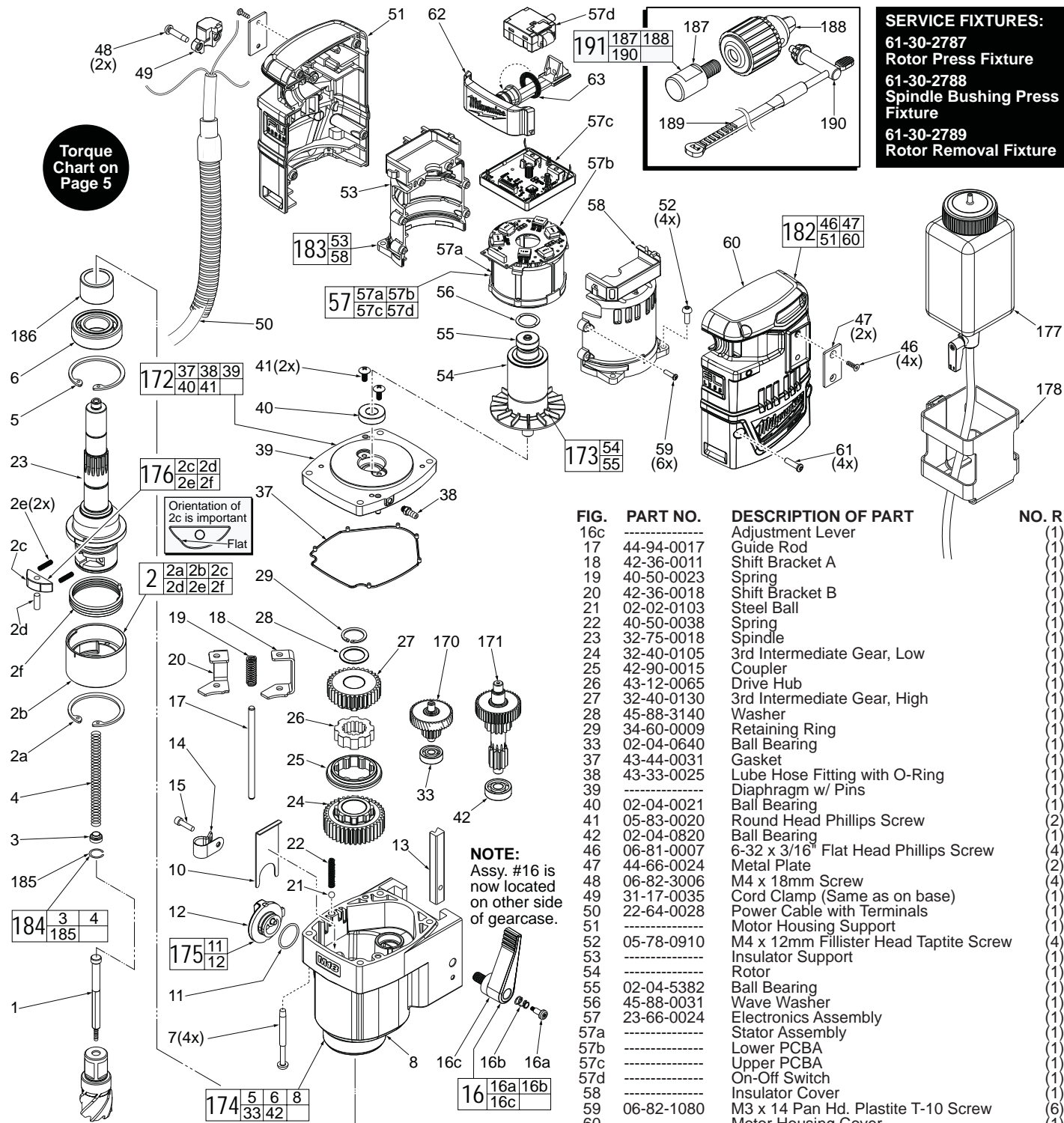

FIG.	PART NO.	DESCRIPTION	NO. REQ.
1	44-60-0007	Ejector Pin Assembly	(1)
2	48-66-0025	Chuck Collar	(1)
2a	34-60-0003	Retaining Ring	(1)
2b	42-76-0017	Spindle Collar	(1)
2c	43-96-0015	Spindle Key	(1)
2d	44-60-0004	Pin	(1)
2e	40-50-0097	Spring	(2)
2f	40-50-0366	Torsion Spring	(1)
3	-----	Spindle Plug	(1)
4	-----	Spring	(1)
5	34-60-0007	Retaining Ring	(1)
6	02-04-0011	Ball Bearing	(1)
7	06-82-0004	M5 x 55mm Pan Hd. T-20 Screw	(4)
8	-----	Gearcase	(1)
10	44-90-0006	Shift Knob Retainer	(1)
11	34-40-1570	O-Ring	(1)
12	-----	Speed Knob	(1)
13	44-20-0021	Dovetail Lock Block	(1)
14	31-17-0030	Cord Clamp	(1)
15	05-81-1410	M4 x 16 Pan Hd. T-20 Screw	(1)
16	44-10-0016	Adjustment Lever Assembly	(1)
16a	-----	Screw	(1)
16b	-----	Spring	(1)

FIG.	PART NO.	DESCRIPTION OF PART	NO. REQ.
16c	-----	Adjustment Lever	(1)
17	44-94-0017	Guide Rod	(1)
18	42-36-0011	Shift Bracket A	(1)
19	40-50-0023	Spring	(1)
20	42-36-0018	Shift Bracket B	(1)
21	02-02-0103	Steel Ball	(1)
22	40-50-0038	Spring	(1)
23	32-75-0018	Spindle	(1)
24	32-40-0105	3rd Intermediate Gear, Low	(1)
25	42-90-0015	Coupler	(1)
26	43-12-0065	Drive Hub	(1)
27	32-40-0130	3rd Intermediate Gear, High	(1)
28	45-88-3140	Washer	(1)
29	34-60-0009	Retaining Ring	(1)
33	02-04-0640	Ball Bearing	(1)
37	43-44-0031	Gasket	(1)
38	43-33-0025	Lube Hose Fitting with O-Ring	(1)
39	-----	Diaphragm w/ Pins	(1)
40	02-04-0021	Ball Bearing	(1)
41	05-83-0020	Round Head Phillips Screw	(2)
42	02-04-0820	Ball Bearing	(1)
46	06-81-0007	6-32 x 3/16" Flat Head Phillips Screw	(4)
47	44-66-0024	Metal Plate	(2)
48	06-82-3006	M4 x 18mm Screw	(4)
49	31-17-0035	Cord Clamp (Same as on base)	(1)
50	22-64-0028	Power Cable with Terminals	(1)
51	-----	Motor Housing Support	(1)
52	05-78-0910	M4 x 12mm Fillister Head Taptite Screw	(4)
53	-----	Insulator Support	(1)
54	-----	Rotor	(1)
55	02-04-5382	Ball Bearing	(1)
56	45-88-0031	Wave Washer	(1)
57	23-66-0024	Electronics Assembly	(1)
57a	-----	Stator Assembly	(1)
57b	-----	Lower PCBA	(1)
57c	-----	Upper PCBA	(1)
57d	-----	On-Off Switch	(1)
58	-----	Insulator Cover	(1)
59	06-82-1080	M3 x 14 Pan Hd. Plastite T-10 Screw	(6)
60	-----	Motor Housing Cover	(1)
61	06-82-0018	M4 Pan Hd. Plastite T-20 Screw	(4)
62	42-42-0021	Switch Button Assembly	(1)
63	40-50-0031	Garther Spring	(1)
170	14-29-0041	Pinion/1st Intermediate Gear Assembly	(1)
171	14-29-0061	Pinion/2nd Intermediate Gear Assembly	(1)
172	14-13-0035	Diaphragm Assembly w/Bearings and Seal	(1)
173	23-40-0085	Rotor Assembly	(1)
174	14-30-0023	Gearcase Assembly	(1)
175	43-98-0071	Speed Knob Assembly	(1)
176	43-96-0091	Spring/Key Kit	(1)
177	49-76-0040	Lubricant Container/Control Assy. (Accessory)	(1)
178	42-36-0022	Container Bracket Assembly	(1)
181	10-20-0578	Warning Label	(1)
182	31-44-2787	Motor Housing Assembly	(1)
183	23-16-2787	Insulator Assembly	(1)
184	14-46-2787	Ejector Spring Kit	(1)
185	44-90-0012	Retainer	(1)
186	42-40-0101	Bushing	(1)
187	-----	Chuck Adapter	(1)
188	48-66-1355	1/2" Keyed Chuck (with Key)	(1)
189	48-66-4040	Key Holder	(1)
190	48-66-3280	Chuck Key	(1)
191	49-59-0020	3/4" Weldon to 1/2" Chuck Adapter w/Key	(1)
-----	-----	Danger Label (Not Shown)	(1)

LUBRICATION:

Type "Y" Grease, No. 49-08-5270 (6 oz. tube)
Use approximately 85 grams, 3 ounces

LUBRICATION NOTE: When servicing the drill motor, 90-95% of old grease must be removed prior to new grease being added.

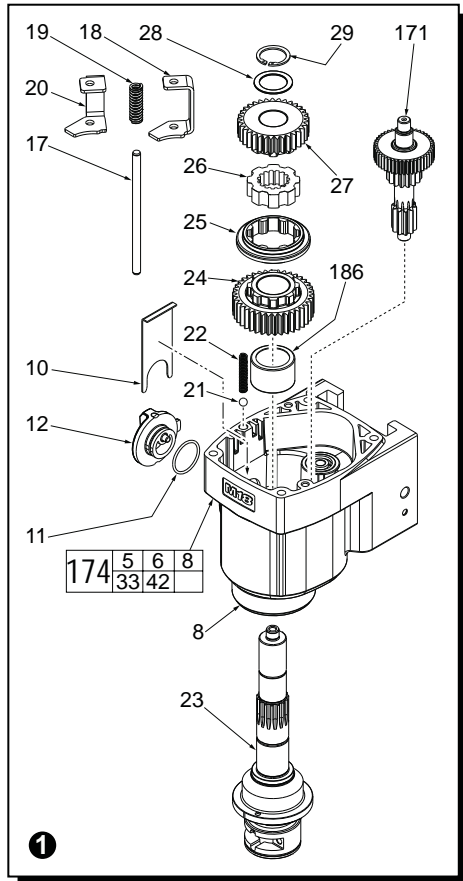

1 Install parts shown into/onto Gear Case Assembly (174) prior to applying any lubrication.

2 Apply 13 grams (approximately .45 ounces) of grease in this area of the gear case prior to installing the Pinion/1st Intermediate Gear Assembly (170).

3 With the aid of a grease gun, place 26 grams (approximately .9 ounces) in and around the gear case cavity for the 3rd Intermediate Gear system (24, 25, 26 and 27).

4 Apply a heavy coating of grease over the entire Pinion/1st Intermediate Gear Assembly (170).

5 Install the assembly (170) into gear case and place 5-8 grams (.17-.28 ounces) fully around gear space.

6 This step will require 39 grams (1.4 ounces) of grease. Place 13 grams (approximately .45 ounces) of grease at each of three positions over and around the Pinion/1st Intermediate Gear Assembly (170).

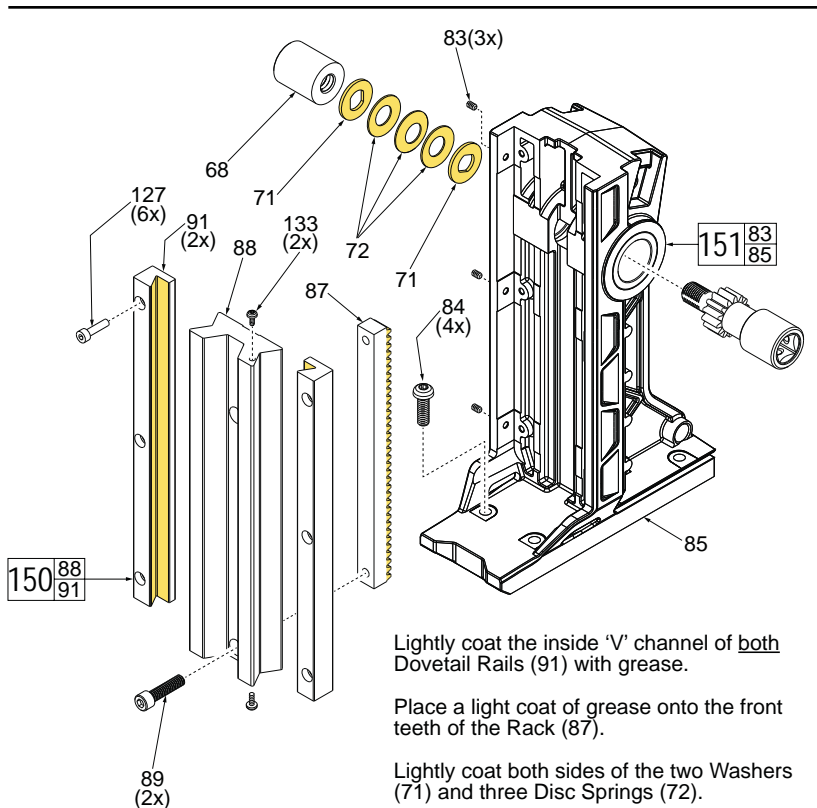
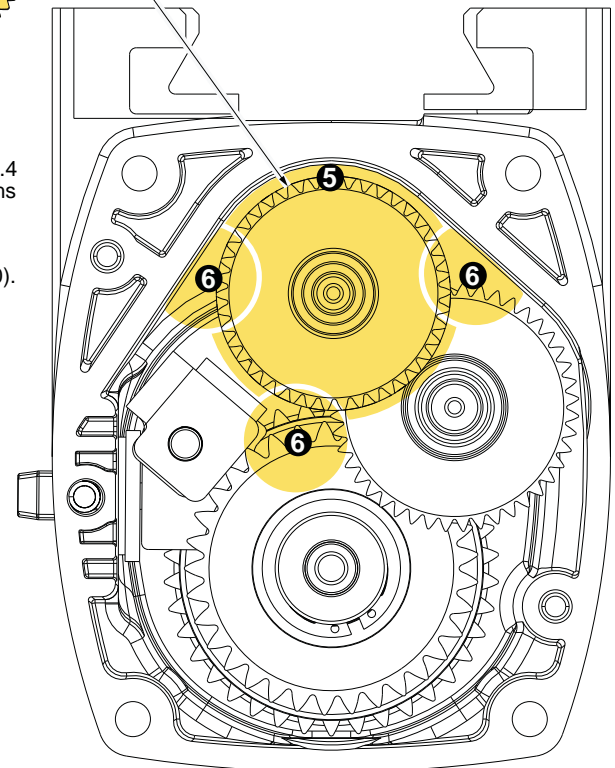
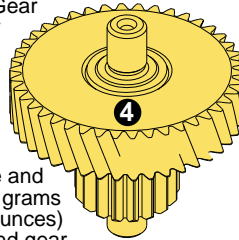
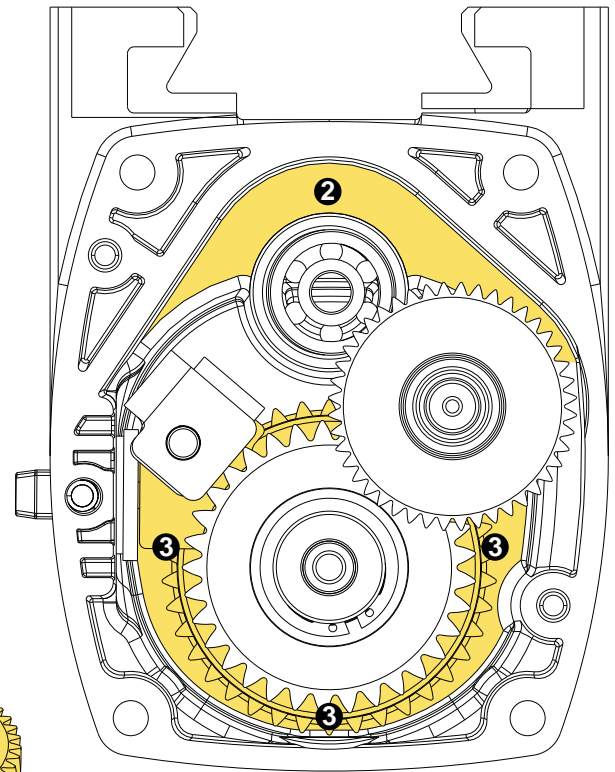

Lightly coat the inside 'V' channel of both Dovetail Rails (91) with grease.

Place a light coat of grease onto the front teeth of the Rack (87).

Lightly coat both sides of the two Washers (71) and three Disc Springs (72).

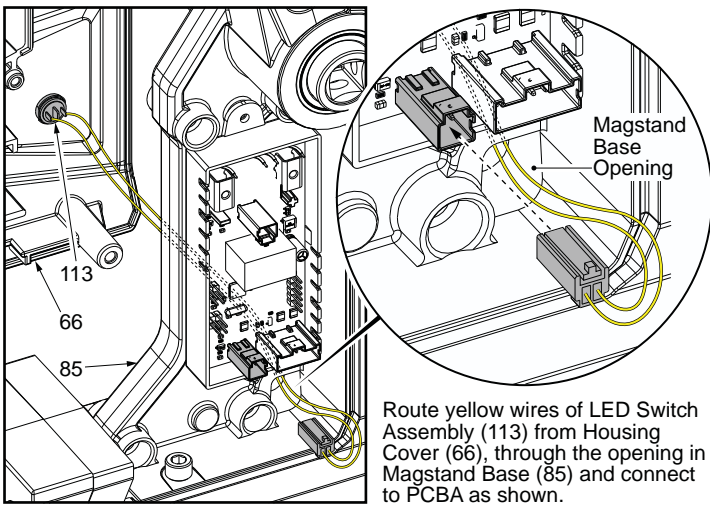

Route yellow wires of LED Switch Assembly (113) from Housing Cover (66), through the opening in Magstand Base (85) and connect to PCBA as shown.

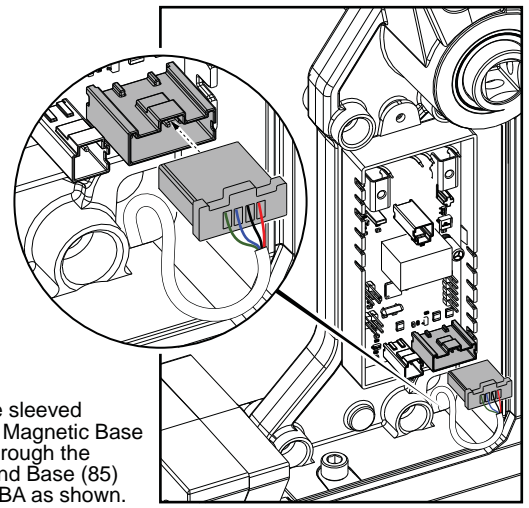

Route the four wire sleeved assembly from the Magnetic Base Assembly (155), through the opening in Magstand Base (85) and connect to PCBA as shown.

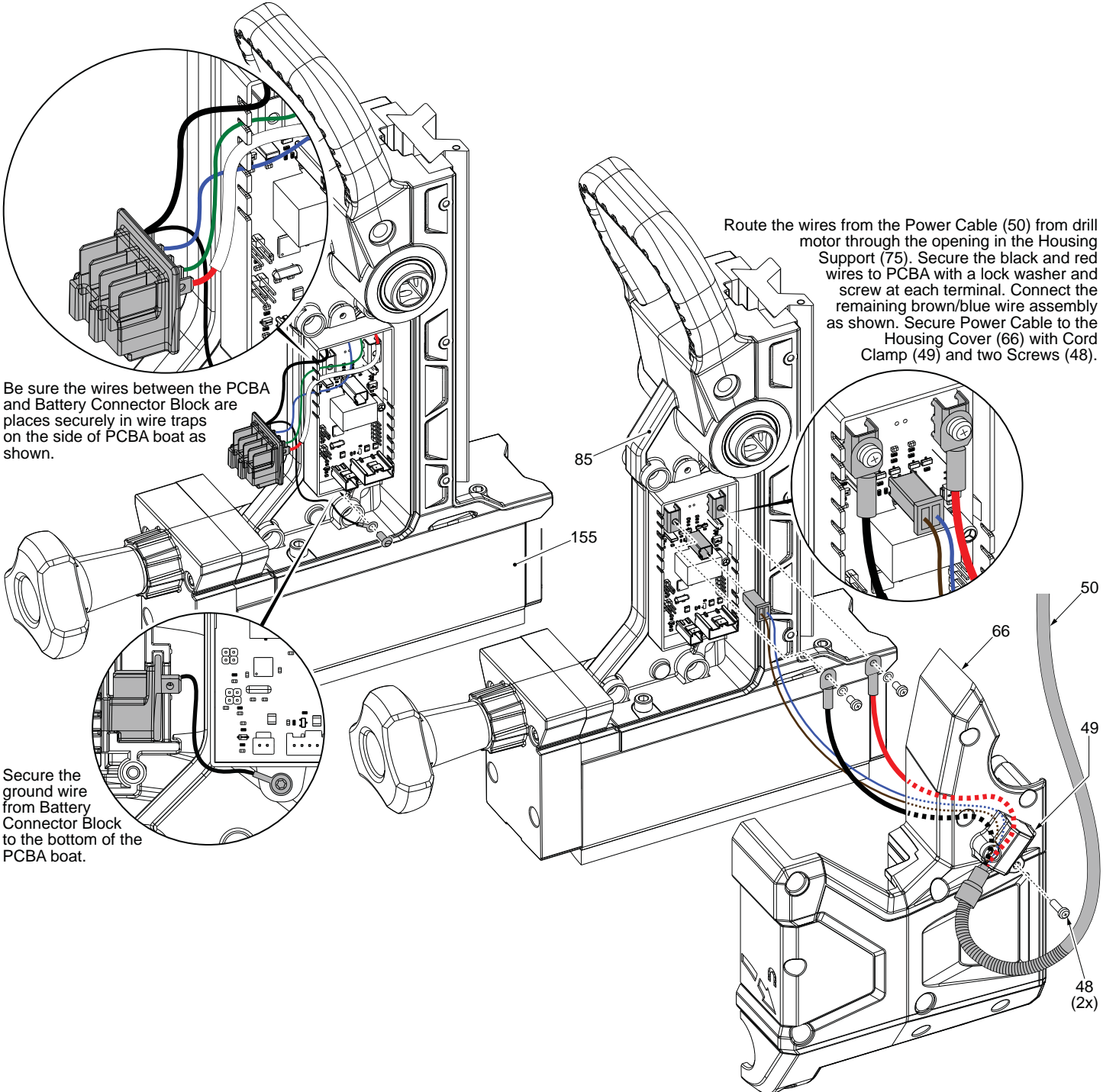

Be sure the wires between the PCBA and Battery Connector Block are placed securely in wire traps on the side of PCBA boat as shown.

Route the wires from the Power Cable (50) from drill motor through the opening in the Housing Support (75). Secure the black and red wires to PCBA with a lock washer and screw at each terminal. Connect the remaining brown/blue wire assembly as shown. Secure Power Cable to the Housing Cover (66) with Cord Clamp (49) and two Screws (48).

Secure the ground wire from Battery Connector Block to the bottom of the PCBA boat.

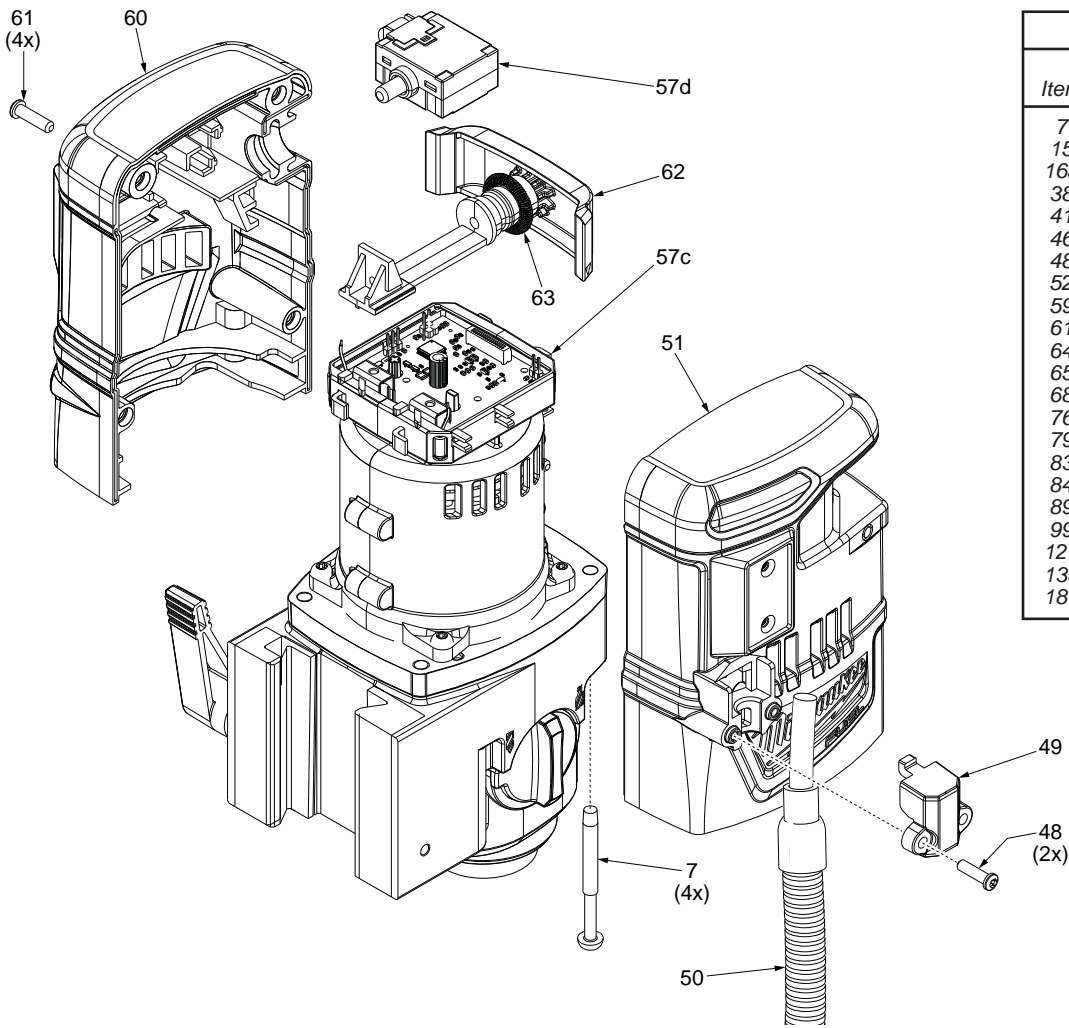

SCREW TORQUE CHART			
Item	Part Number	Seat Torque	
		(Kg./cm.)	(In./lbs.)
7	06-82-0040	28-33	24-28
15	05-81-1410	4-6	3-5
16a	-----	6-10	5-8
38	43-33-0025	4-8	3-7
41	05-83-0020	15-20	13-17
46	06-81-0007	7-10	6-8
48	06-82-3006	13-17	11-14
52	05-78-0910	12-18	10-15
59	06-82-1080	10-15	8-13
61	06-82-0018	15-20	13-17
64	06-82-0009	28-33	24-28
65	06-82-0011	15-20	13-17
68	43-12-0055	460	399
76	05-74-0014	35-40	30-34
79	05-83-0010	3-7	2-6
83	06-83-0015	4	3
84	05-81-2787	28-33	24-28
89	06-75-3050	28-33	24-28
99	-----	20-25	17-21
127	05-74-0013	25-30	21-26
133	05-80-2787	10-15	8-13
187	42-04-0200	50-75	43-65

Connect the wires from the Power Cable (50) to the drill motor as shown. Secure the terminated red and black wires with a lock washer and screw at each terminal location on the Upper PCBA (57c). Insert the male connector with the thin brown and blue wires from the Power Cable to the corresponding female connector on the Upper PCBA. With the Switch Button Assembly (62) and Garter Spring (63) in place, assemble together two motor housing halves (51 and 60) and secure with screws (61 and 7). Secure Power Cable to the Motor Housing Support (51) with Cord Clamp (49) and two Screws (48).

