

Ride-on Brushcutter

**CMX 227/ CM226/ CMX186/ CM185**

---

# Operator's Manual

---

**F1MASAO**

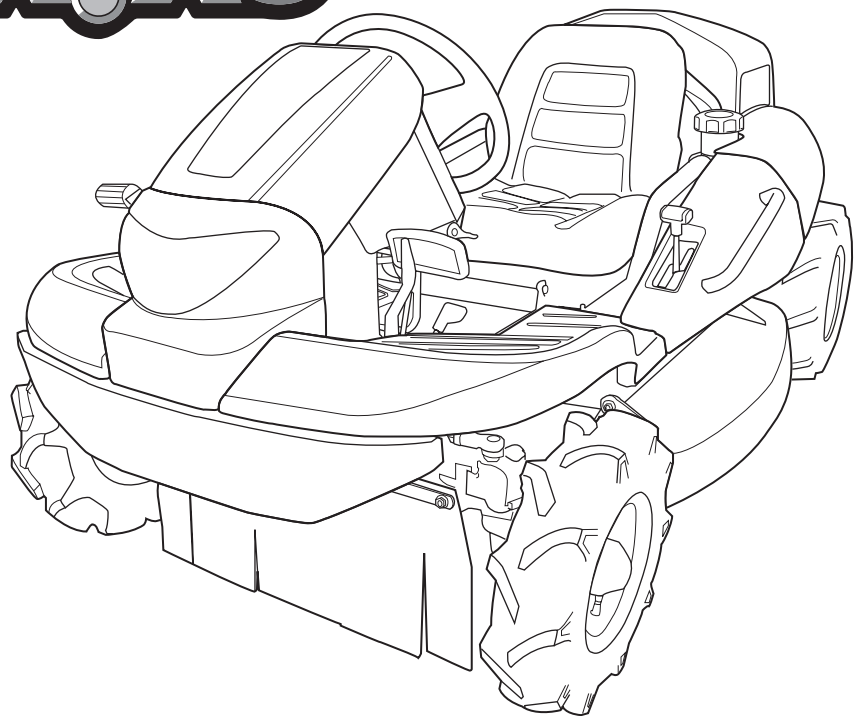

## **⚠ WARNING!**

Read this manual completely before operating or maintaining this machine. Failure to follow safety precautions could result in serious injury or death. Keep this manual for future reference by you and by all those who operate and maintain this machine.

5335 5311 004

---

**Original Instructions** (in English)

---

# CHIKUSUI CANYCOM, INC.

<http://www.canycom.co.jp/>

---

CHIKUSUI CANYCOM, INC.

90-1 Fukumasu, Yoshii-machi,

Ukiha-shi, Fukuoka, Japan 839-1396

Sales Headquarters (International) TEL +81-(0)943-75-2195

FAX +81-(0)943-75-4396

Authorized Dealer

Rent this machine at:



---

## Notice to Users and Maintenance Personnel

Thank you for purchasing this machine.

This manual provides information needed for safe and effective use of this machine to those who operate or maintain machine. Make sure to read and understand the manual thoroughly before operating this product. Also make sure to read the separate operator's manual for engine.

### **⚠ WARNING!**

- **This machine can be very dangerous if the safety precautions in this manual and on the labels attached to this machine are not followed. Read and understand this manual and safety labels on machine thoroughly before using this machine. Always follow the instructions and safety precautions, or serious injury or death could result.**
- **This machine should only be used for its intended purpose: cutting grass and bushes. Any other use could be dangerous.**
- **This machine may not be operated on public road or what is considered to be public road. It is the sole responsibility of the operator to consult the local regulations.**
- **Do not modify this machine, or do not operate this machine with the safety covers removed or open. A serious accident could result.**

### **⚠ CAUTION!**

- **Store this manual in a safe, accessible place for easy reference.**
-

---



## Notice to Owner

### CAUTION!

- Be sure that everyone who uses this machine, including those who rent or lease this machine, receives a copy of this Operator's Manual and understands the importance of reading and following the information in this manual.

## Warning Terms Used in this Manual

In this manual, the following four warning terms are used to signal the four levels of hazard (or seriousness of possible accidents). Read and understand what they mean and always follow the instructions in this manual.

| Warning Term  | Definition  |
|---|---|
|  <b>DANGER!</b>  | Indicates an imminently hazardous situation which will result in death or serious injury if the user does not follow the procedures or the instructions.                            |
|  <b>WARNING!</b> | Indicates a potentially hazardous situation which could result in death or serious injury if the user does not follow the procedures or the instructions.                           |
|  <b>CAUTION!</b> | Indicates a potentially hazardous situation which could result in minor to moderate injury or damage to the machine if the user does not follow the procedures or the instructions. |
| <u>NOTE</u>   | Indicates important information which needs particular attention.   |

---

---

# Warranty and After-Sales Service

## Warranty

CHIKUSUI CANYCOM, INC. guarantees this product, based on the terms of warranty.

## After-Sales Service

Consult your local CANYCOM dealer or our company's sales department regarding service orders or any questions or problems that may arise when using this machine. Please make sure to have the product name, serial number, and the make and type of engine handy at the time of contact. The model and serial number can be found on the model label as shown below, and the make and type of the engine can be found in Chapter 3 "**Specifications**" of this manual (Page15).

### Location of Model Label

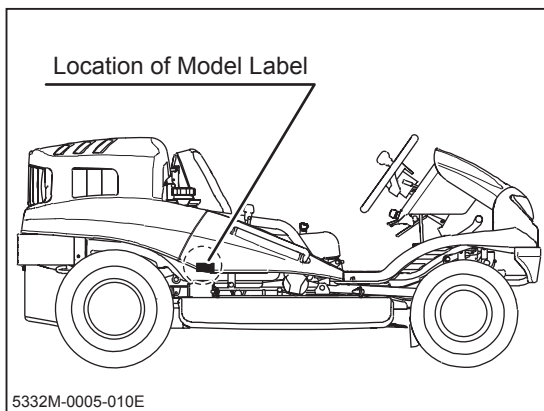

### Model Label



## Availability of Spare Parts

The replacement or repair parts for this product shall remain available for seven years after the production of this type of machine is discontinued.

---

---

# Contents

|   |           |
|---|-----------|
| <b>1. Safety</b>                        | <b>1</b>  |
| Safety Labels . . . . .                 | 1         |
| Safety Mechanisms . . . . .             | 3         |
| Safety Precautions . . . . .            | 4         |
| Training . . . . .                      | 4         |
| Preparation . . . . .                   | 5         |
| Operation . . . . .                     | 6         |
| Servicing . . . . .                     | 10        |
| <b>2. Controls and Components</b>       | <b>11</b> |
| Name and Function of Controls . . . . . | 11        |
| <b>3. Specifications</b>                | <b>15</b> |
| Product Specifications . . . . .        | 15        |
| Contents of Tool Bag . . . . .          | 16        |
| <b>4. Operation</b>                     | <b>17</b> |
| Preparation . . . . .                   | 17        |
| Pre-start up Inspection . . . . .       | 17        |
| Checking and Filling Fuel . . . . .     | 17        |
| Adjusting Steering Wheel . . . . .      | 18        |
| Adjusting Seating Position . . . . .    | 20        |
| Adjusting Drive Pedal . . . . .         | 22        |

---

---

|  |           |
|--|-----------|
| <b>Driving</b> .....                                 | <b>22</b> |
| Starting .....                                       | 22        |
| Driving .....  | 26        |
| Stopping .....                                       | 28        |
| Shifting .....                                       | 30        |
| Shifting Between 2WD and AWD (CMX227 / CMX186) ..... | 30        |
| Locking Differential .....                           | 31        |
| Parking .....  | 32        |
| <b>Working</b> .....                                 | <b>34</b> |
| Inspecting Cutting Blade .....                       | 34        |
| Adjusting Cutting Height .....                       | 34        |
| Cutting .....  | 35        |
| Adjusting Cutting Blade Shield .....                 | 40        |

## **5. Maintenance 41**

|   |           |
|---|-----------|
| <b>Maintenance Schedule</b> .....           | <b>41</b> |
| Engine .....                                | 41        |
| Chassis .....                               | 42        |
| <b>List of Fluids and Lubricants</b> .....  | <b>45</b> |
| <b>Greasing Points</b> .....                | <b>46</b> |
| Greasing Points (CMX227 / CMX186) .....     | 46        |
| Greasing Points (CM226 / CM185) .....       | 47        |
| <b>List of Consumables and Spares</b> ..... | <b>48</b> |

---

---

|  |           |
|--|-----------|
| <b>Removing and Installing Body Panels . . . . .</b> | <b>50</b> |
| Front Cover . . . . .                                | 50        |
| Head Lamp . . . . .                                  | 51        |
| Engine Hood . . . . .                                | 52        |
| Lower Rear Cover . . . . .                           | 52        |
| Step . . . . .                                       | 52        |
| Seat Bracket . . . . .                               | 53        |
| Cutting Blade Shield . . . . .                       | 53        |
| <b>Engine . . . . .</b>                              | <b>55</b> |
| Engine Oil . . . . .                                 | 55        |
| Oil Filter Cartridge . . . . .                       | 57        |
| Air Cleaner . . . . .                                | 57        |
| Spark Plugs . . . . .                                | 58        |
| <b>Drive Train . . . . .</b>                         | <b>59</b> |
| Tires . . . . .                                      | 59        |
| Transmission Oil . . . . .                           | 60        |
| Front Axle Oil (CMX227 / CMX186) . . . . .           | 60        |
| HST (Hydrostatic Transmission) Fluid . . . . .       | 61        |
| Drive Belt . . . . .                                 | 63        |
| Parking Brake . . . . .                              | 64        |
| <b>Cutting System . . . . .</b>                      | <b>65</b> |
| Cutting Blades . . . . .                             | 65        |
| Cutting Rotary Drive Belt . . . . .                  | 68        |
| Cutting Rotary Brake . . . . .                       | 69        |
| <b>Electrical System . . . . .</b>                   | <b>70</b> |
| Battery . . . . .                                    | 70        |
| Fuses . . . . .                                      | 72        |
| Light Bulbs . . . . .                                | 73        |
| <b>After Use Care . . . . .</b>                      | <b>75</b> |
| Cutting System . . . . .                             | 75        |

---



---

|                              |           |
|------------------------------|-----------|
| After Normal Use .....       | 76        |
| After Cold Weather Use ..... | 77        |
| <b>Storage .....</b>         | <b>78</b> |

## **6. Troubleshooting 79**

|                       |    |
|-----------------------|----|
| Troubleshooting ..... | 79 |
|-----------------------|----|

## **7. Transporting 84**

|               |    |
|---------------|----|
| Hauling ..... | 84 |
|---------------|----|

|                             |    |
|-----------------------------|----|
| Loading and Unloading ..... | 84 |
|-----------------------------|----|

|                |    |
|----------------|----|
| Hoisting ..... | 85 |
|----------------|----|

## **Warranty**

Warranty Certificate is attached at the end of this manual.

\* Have the warranty certificate signed after you have received and fully understood the instructions for handling this machine and received the receipt.

## **Appendix**

- Operator's Manual for the Engine

\* Be sure to read and understand it together with this manual .

---

## Safety Labels

The safety labels shown on the next page are attached to the machine. See the illustration below for the location and the illustration on the next page for the content of each label on the machine.

- Locate all the warning labels attached to this machine. Read and follow the instructions and precautions in them. Failure to do so could result in serious injury or death to the operator or bystanders.
- Keep the labels clean and legible. Do not use solvents or gasoline to clean the labels.
- Replace these labels immediately if they have been removed, have fallen off or become illegible. Use the part number, on the label or shown in this manual, to order a replacement label from your CANYCOM representative.

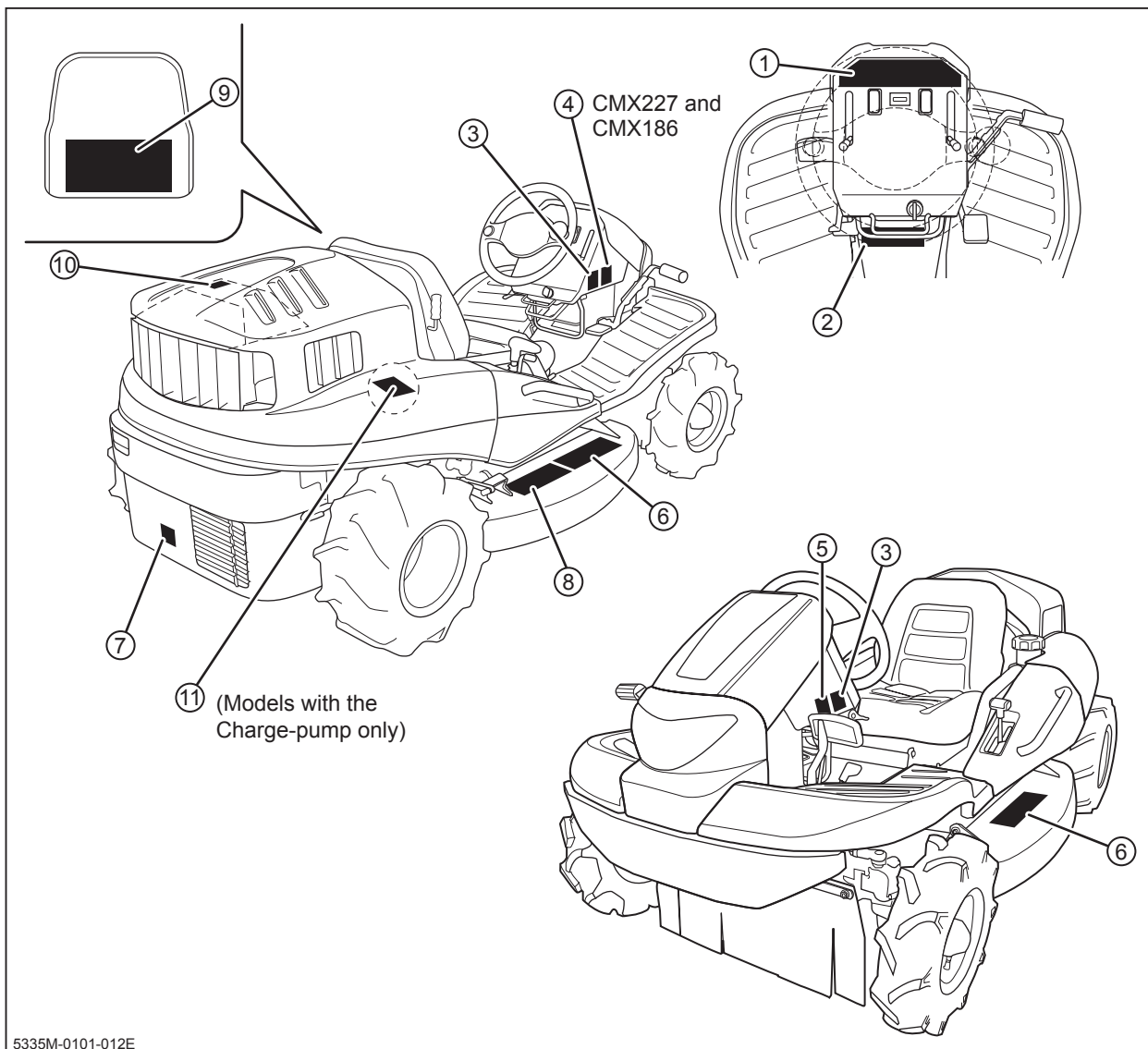

5335M-0101-012E

① 5332 5109 000

**WARNING/AVERTISSEMENT  
WARNUNG/AVVERTENZA**

- Engage cutting blade clutch only when cutting. Keep it disengaged all the other times.
- Embrayez la lame uniquement pour tondre. Laissez-la débrayée le reste du temps.
- Schalten Sie die Mähwerkskupplung nur ein, wenn Sie mähen. Lassen Sie diese ausgeschaltet wenn das Mähen nicht erforderlich ist!
- Inestate la lama solo in fase di taglio. In tutti gli altri casi, la lama non deve essere innestata.

**CANYCOM**  
**Head lamp**

③ 5332 5121 000



④ 5332 5122 000

**CAUTION / ATTENTION  
VORSICHT / ATTENZIONE**

- Use 2WD mode under normal condition.
- Stop before shifting between 2WD and AWD modes.
- Utilisez le mode 2WD pour des conditions normales.
- Arrêtez-vous avant de changer de mode: 2WD ou AWD.
- Nutzen Sie im normalen Einsatz den 2WD Antrieb.
- Bringen Sie die Maschine zum Stillstand bevor Sie zwischen 2WD und AWD Antrieb wechseln.
- In condizioni di normale utilizzo usare solo la trazione a 2WD.
- Prima di variare la trazione da 2WD a AWD fermatevi.

② 5332 5114 000

**CAUTION/ATTENTION  
VORSICHT/ATTENZIONE**

- Do not hold the drive lever and press the brake pedal at the same time.
- Ne prenez pas en main le levier d'avancement en même temps que vous utilisez la pédale de frein.
- Betätigen Sie nicht den Fahrtrieb (Hebel oder Pedal) gleichzeitig.
- Non spingete la leva di avanzamento e premete il pedale del freno contemporaneamente.

**ON** **OFF**

⑤ 5332 5128 000



⑥ 5321 5116 000



⑦ 5305 5326 000

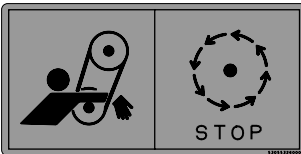

⑧ 5332 5127 000

**WARNING/AVERTISSEMENT/WARNUNG/AVVERTENZA**

- When a blade is broken, replace it immediately. Always replace blades in pairs. Always replace blade pins and wave washers also. Vibration may occur.
- Lorsqu'une lame casse, la remplacez immédiatement. Il faut systématiquement remplacer les lames par paires. Remplacez systématiquement les épingles de lames et les rondelles. Risque de créer des vibrations.
- Wenn eine Klinge zerbricht, ersetzen Sie sie sofort. Ersetzen Sie immer Messerpaare. Ersetzen Sie auch die Messerbolzen und Wellenwascher. Gefahr von Vibrationen.
- In Falle der Beschädigung eines Messer, tauschen Sie dieses umgehend aus. Messer immer paarweise austauschen. Immer Messerbolzen und Befestigungsteile mit den Messern ersetzen. Falls die Bolzen der Messerträger bis zum Limit abgenutzt sein, einen Riss oder Deformationen aufweisen, kontaktieren Sie Ihre Canycom-Vertretung um den Messerträger umgehend austauschen zu lassen. Dies kann zum Bruch des Messerträgers führen, welcher aus dem Mähwerk geschleudert werden kann.
- Se si rompe una lama, sostituirla immediatamente. Sostituire sempre anche i perni e le rondelle. Non accendo si potrebbero verificare vibrazioni eccessive.
- Quando il supporto lama è usurato oltre il limite, o presenta crepe o deformazioni, contattate il concessionario CANYCOM per farlo sostituire subito. Infatti il supporto lama potrebbe rompersi ed essere proiettato. Se si aggroviglia del materiale sulle lame, scopriete il motore e togliete il groviglio. Non facendolo si potrebbero verificare danni ed eccessive vibrazioni.
- Quando maneggate le lame indossate sempre guanti protettivi pesanti e fate particolare attenzione. Le lame e il supporto lama potrebbero diventare particolarmente affilati in seguito all'usura.

⑨ 5335 5125 000

**WARNING/AVERTISSEMENT/WARNUNG/AVVERTENZA**

- Keep fire away when refueling. Always stop engine and let engine and muffler cool down before refueling. Fill up to the upper limit (top of filter inside filler).
- Nicht in der Nähe von Feuer betanken. Schalten Sie immer den Motor ab und warten Sie bis der Motor und Auspuff abgekühlt sind, bevor Sie neu betanken. Befüllen Sie nur bis zur maximalen Füllmenge (bis zum Anfang des inneren Füllers)
- Fill below the upper limit when working on an incline.
- Bleiben Sie beim Befüllen des Tanks unterhalb des Füllers, wenn Sie an Neigungen Arbeiten verrichten wollen.
- Start engine in a well ventilated place. Always scan around and ride on the machine when starting.
- Starten Sie den Motor nur in gut belüfteter Umgebung. Achten Sie immer auf Ihre Umgebung und seien Sie sitzend auf der Maschine, wenn Sie den Motor starten.
- Do not allow persons to come near the machine when traveling or cutting.
- Sorgen Sie für ausreichenden Sicherheitsabstand zu Ihren Mitmenschen, wenn Sie mit der Maschine Mäharbeiten verrichten oder auf dieser fahren.
- Dive forward when cutting.
- Fahren Sie vorwärts während Sie mähen.
- Check the safety of the surroundings when traveling or cutting. Do not start, turn, accelerate or stop suddenly.
- Überprüfen Sie immer die Sicherheit Ihrer Umgebung wenn Sie mit der Maschine Mäharbeiten verrichten oder fahren. Unterlassen Sie schnell Start, schnelle Lenkeinschläge, abruptes Gas geben oder abruptes Anhalten der Maschine.
- Check holes, ditches and obstacles before traveling or cutting.
- Überprüfen Sie die Arbeitsfläche auf Löcher, Äste, Unebenheiten und andere Hindernisse bevor Sie Mäharbeiten verrichten oder die Fahrt antreten.
- Check the incline before traveling or cutting. Do not use the machine on an incline steeper than 25 degrees(CM227) 15 degrees(CM226/185). On an incline less than 25 degrees or an undulating ground, drive slow.
- Überprüfen Sie die Neigung der Arbeitsfläche bevor Sie die Mäharbeit oder Fahrt antreten. Nutzen Sie die Maschine nicht an Neigungen über 25 Grad(CM227)15 Grad (CM226/185). An einer Neigung weniger 25 Grad(CM227)15 Grad(CM226/185) oder auf unwegsamen Gelände, passen Sie Ihre Geschwindigkeit den Gegebenheiten an.
- Ne pas approcher de flamme lors du remplissage du réservoir d'essence. Toujours arrêter le moteur et le laisser refroidir.
- Spiegnete sempre il motore e aspettate che motore e marmitta si raffreddino prima di eseguire il rifornimento di carburante.
- Riemplite il serbatoio al di sotto del limite superiore quando dovete lavorare in pendenza.
- Remplissez en dessous de la limite supérieure pour travailler sur une pente.
- Démarruez le moteur dans un lieu ventilé. Toujours regarder autour et d'écouter sur la machine pour démarrer.
- Avviate il motore in una zona ben ventilata. Controllate sempre l'ambiente circostante e salite sulla macchina prima di avviare il motore.
- Ne laissez personne s'approcher de la machine en déplacement ou en tonte.
- Non permettete ad altre persone di avvicinarsi alla macchina quando siete in movimento o quando la state utilizzando.
- Tendez en marche avant.
- Vérifiez la sécurité aux alentours en déplacement ou en tonte.
- Non pas démaner, tourner, accélérer ou stopper brutalement.
- Tagliando l'erba procedete in avanti.
- Répérez les trous et les fossés avant de vous déplacer ou de tondre.
- Prima di utilizzare la macchina, controllate che non ci siano buche, fossi e ostacoli.
- Vérifiez la pente avant de vous déplacer ou de tondre. Ne pas utiliser la machine sur une pente supérieure à 25 degrés (CM227)15 degrés(CM226/185). Conduisez lentement sur une pente inférieure à 25 degrés(CM227)15 degrés(CM226/185) ou sur un terrain bosselé.
- Prima di utilizzare la macchina verificate la pendenza. Non procedete su pendenza superiori a 25 gradi(CM227)15 gradi(CM226/185). Su pendenze inferiori a 25 gradi (CM227)15 gradi(CM226/185) o su terreni irregolari procedete comunque lentamente.

⑩ 5332 5127 000



⑪ 3667 5063 000



## Safety Mechanisms

This product is equipped with the following safety mechanisms.

### Start Interlock Mechanism

Engine can be started only when parking brake is in [(P)] (engaged)] position and cutting rotary clutch in [OFF] position. This is to prevent unintended movement of machine or cutting blade when starting engine.

### Automatic Blade Stopping Mechanism

Engine stops if operator is not seated while cutting blade is rotating. This is to reduce the possibility of accident related to moving blade when machine is turned over.

## Safety Precautions

This section contains safety precautions to follow when operating and maintaining the machine. Read and understand the precautions in this section as well as throughout this manual and follow them when operating or maintaining the machine. Failure to follow safety precautions could result in property damage, serious injury or death to the operator or bystanders.

## Training

All operators and mechanics should receive practical instructions from their employer or renter. Such instructions should cover the following issues:

- It is essential to familiarize yourself with the controls, safety labels and the proper use of the machine.
- Never allow people unfamiliar with these instructions to operate or service the machine. Do not let anyone under 18 years of age to operate this machine. Local regulations may restrict the minimum age for operating the machine. Consult your local authority.
- The operator is responsible for the accidents or hazards caused to other people or their property.
- This machine has a riding capacity for one person only. Do not carry passengers other than the operator.
- Observe the weight limit of this machine: 120kg.
- Always keep in mind that care and concentration is required when working with ride-on machines.
- Loss of control on a slope cannot be regained by the application of the brake. The main reasons for loss of control are:
  - insufficient grip of tires.
  - excessive speed.
  - misjudging of the ground conditions, especially slopes.

## Preparation

### **WARNING!**

- Fuel is highly flammable. See Checking and Filling Fuel, page 17, for important safety information on handling fuel.
- Always wear protective footwear, long trousers, hardhat, safety glasses and ear protection when operating or servicing the machine. Proper clothing will minimize the chance of injury. Do not operate the equipment if you have long hair, loose clothing, or jewelry; all of which may get tangled in moving parts. Do not operate the machine barefoot or with open sandals.
- Prepare beforehand the working rules and procedures such as signaling and traffic control for the work place. Following such rules will reduce the risk of accidents.
- Never handle fuel or grease, service the engine, or recharge the battery in the presence of fire or spark.
- Perform the daily pre-startup inspection (see Preparation, pages 17) before starting the machine. Repair or replace damaged parts before starting the machine.

## Operation

This machine is intended for cutting grass and bushes. Any other use may pose hazard or cause damage to the machine.

The stability of the machine is affected by the speed, rate of steering, terrain and the operator's weight. Always pay close attention to these factors or a loss of control or tip over could occur, resulting in property damage, serious injury or death.

### General Driving

- Do not operate the engine in a confined space where dangerous carbon monoxide fumes can accumulate.
- Do not touch the engine, muffler or exhaust pipe while the engine is running or soon after it has stopped. These areas will be very hot and can cause burns.
- Do not operate the machine under the influence of alcohol or drugs. Do not operate the machine when you are tired, ill, or not feeling well.
- Always check for obstacles before operating on new terrain. This includes overhead obstacles such as the branches of a tree.
- Before starting the engine and moving the machine, scan around your surroundings and make sure all persons and other vehicles are a safe distance away from the machine.
- On a slippery surface, travel slowly and exercise caution to reduce the chance of skidding or sliding out of control. Never operate on ice.
- Always make certain that there is no obstacle or a person behind the machine when backing up. After confirming that it is safe to back up, move slowly and avoid sharp turns.
- To reduce the risk of tip over, pay special attention when encountering an obstacle or a slope, or when braking on a slope or during a turn. See Driving on a Slope on page 8.
- Never attempt to drive over a large obstacle such as rock or fallen tree.

- Always travel slowly and use extra caution when operating on unfamiliar terrain. Be alert when traveling on changing terrain.
- Never operate on terrain that you are not comfortable with. Avoid terrain that is so rough, slippery or loose that you feel like you could tip over.
- Do not operate the machine near the edge of a cliff, an overhang or a slide area. Pay special attention after heavy rain or earthquake.
- Do not make sudden maneuvers. A sudden start, stop, or turn can make the machine lose control and could cause a tip over. Be especially cautious when traveling on soft or wet ground.
- Drive at a safe speed, taking into account the surface gradient, surface conditions and load.



## Driving on a Slope

### **WARNING!**

- Never use on a slope steeper than 25 degrees for the CMX227 and the CMX186, and 15 degrees for the CM226 and CM185.
  - Driving on a slope can be dangerous. It can result in a tip over and cause serious injury or death. Take the following precautions.
- Always follow proper procedures for driving on a slope as described in this manual.
  - Driving on a slope in a wrong manner can cause a loss of control or a vehicle tip over. Check the terrain carefully before attempting to drive on a slope.
  - Never drive on a slope that you are not comfortable with. Avoid a slope that is so rough, slippery, or loose that you feel like you could tip over.
  - When driving up a slope, proceed at a steady rate of speed and throttle position.
  - Never move the throttle lever, the drive lever, the drive pedal or the steering wheel suddenly.
  - If the engine stalls or loses traction during a climb and cannot make it to the top of the slope, do not try to turn the machine around. Carefully back down slowly, straight down the slope.
  - Drive straight up or down slopes. Avoid turning on a slope.
  - When going over the top of a slope, go slow; an obstacle, a sharp drop, or another vehicle or person could be on the other side of the crest.
  - Avoid driving the machine across a slope.
  - Before driving down a slope, stop and shift auxiliary transmission to [L (low)] position. Drive slowly. Use the engine speed to help keep the machine speed low.

## Cutting

When conducting cutting operation, take the following precautions.

- Always follow the proper procedures for cutting as described in this manual.
- Shutt off the work site. Post signs to inform of the cutting operation. Close off the site with rope if necessary to keep people, especially children, off the work site.
- Pay attention to the surrounding area. Rotating cutting blade throws stones, rocks and debris. This may cause property damage, injury, or death.
- Drive forward when cutting. This best prevents the cutting blades from throwing stones, rocks, or debris.
- Pay attention to obstacles. This includes overhead obstacles such as the branches of a tree.

## Parking

- Park the machine on a flat, level and stable surface. Never park on a slope steeper than 10 degrees. Avoid parking on a slope less than 10 degrees. If parking on a slope less than 10 degrees is absolutely unavoidable, apply the parking brake and block the wheels at the lower end of the machine.
  - Park the machine facing uphill
  - Do not park sideways on a slope.
- Never park on an instable surface. Do not park near the edge of a cliff.
- Observe all the previous precautions for driving, driving on a slope, loading .
- Whenever you park the machine, apply the parking brake and stop the engine. Remove the key whenever you leave the machine unattended to prevent unauthorized use or accidental starting.
- Gasoline is extremely flammable and can be explosive. When parking the machine indoors, make certain that the building is well ventilated and that the machine is not close to any source of flame or spark, including appliances with pilot lights.

## Servicing

- Do not service the machine when the engine is running. If it is absolutely necessary to run the engine while servicing, pay attention to the moving parts.
- Do not operate the engine in a confined space where dangerous carbon monoxide fumes can accumulate.
- Make sure all hydraulic line connectors are tight and all hydraulic hoses and lines are in good condition and leak-free.
- Keep your body and hands away from pinhole leaks or nozzles that eject hydraulic fluid under high pressure. Use paper or cardboard, not your hands, to search for leaks. Hydraulic fluid escaping under pressure can have sufficient force to penetrate the skin and cause serious injury.
- Check all fuel lines on a regular basis for tightness and wear. Tighten or repair them as needed.
- If the engine must be running to perform a service, keep hands, feet, clothing and any part of the body away from any moving part, especially the cooling fan and the belts at the back of the engine.
- Do not touch the engine, muffler, or exhaust pipe while the engine is running or soon after it has stopped. These areas will be very hot and can cause burns.
- The engine must be shut off before checking or adding oil.

## Name and Function of Controls

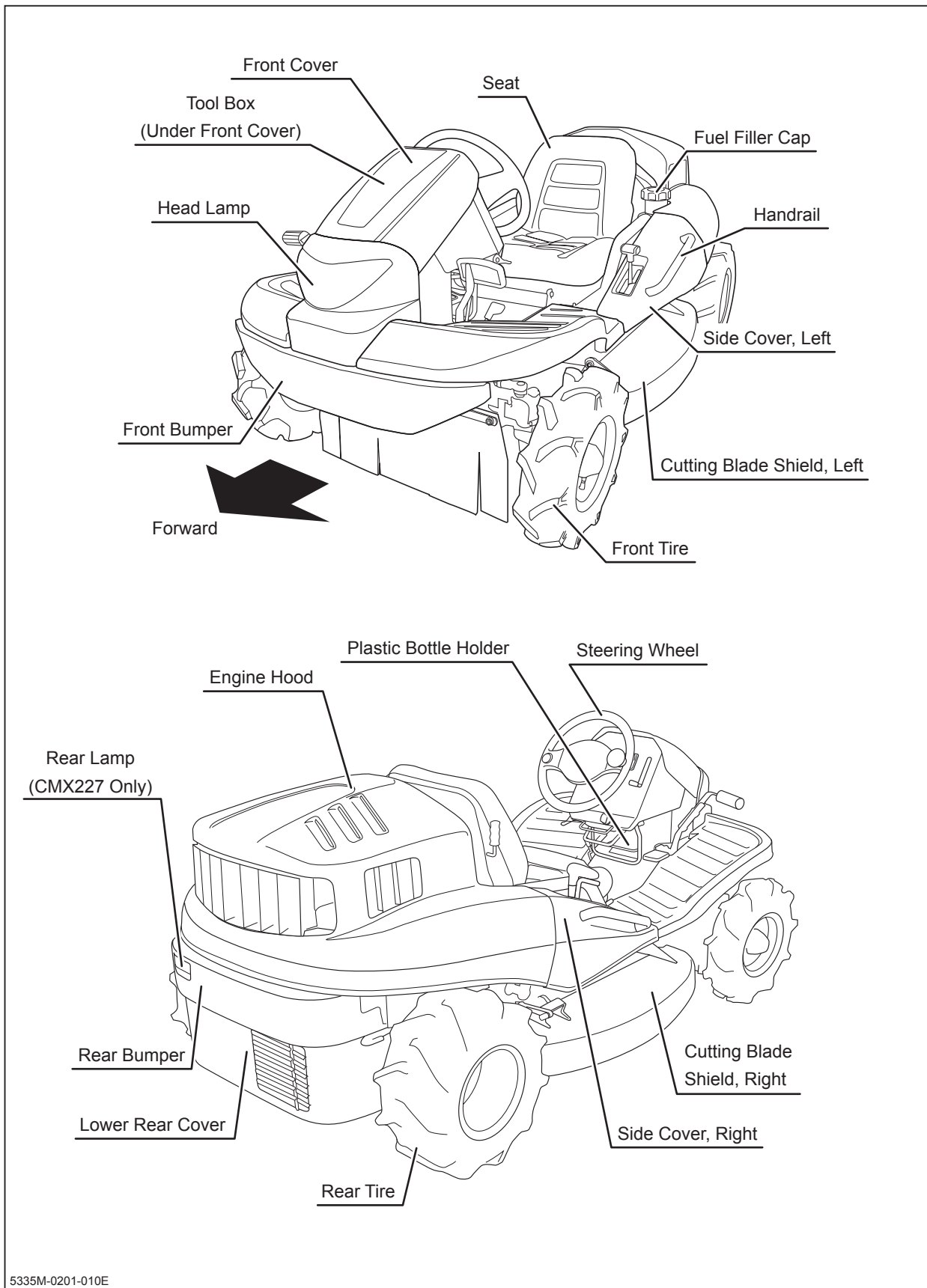

5335M-0201-010E

# 2

# Controls and Components

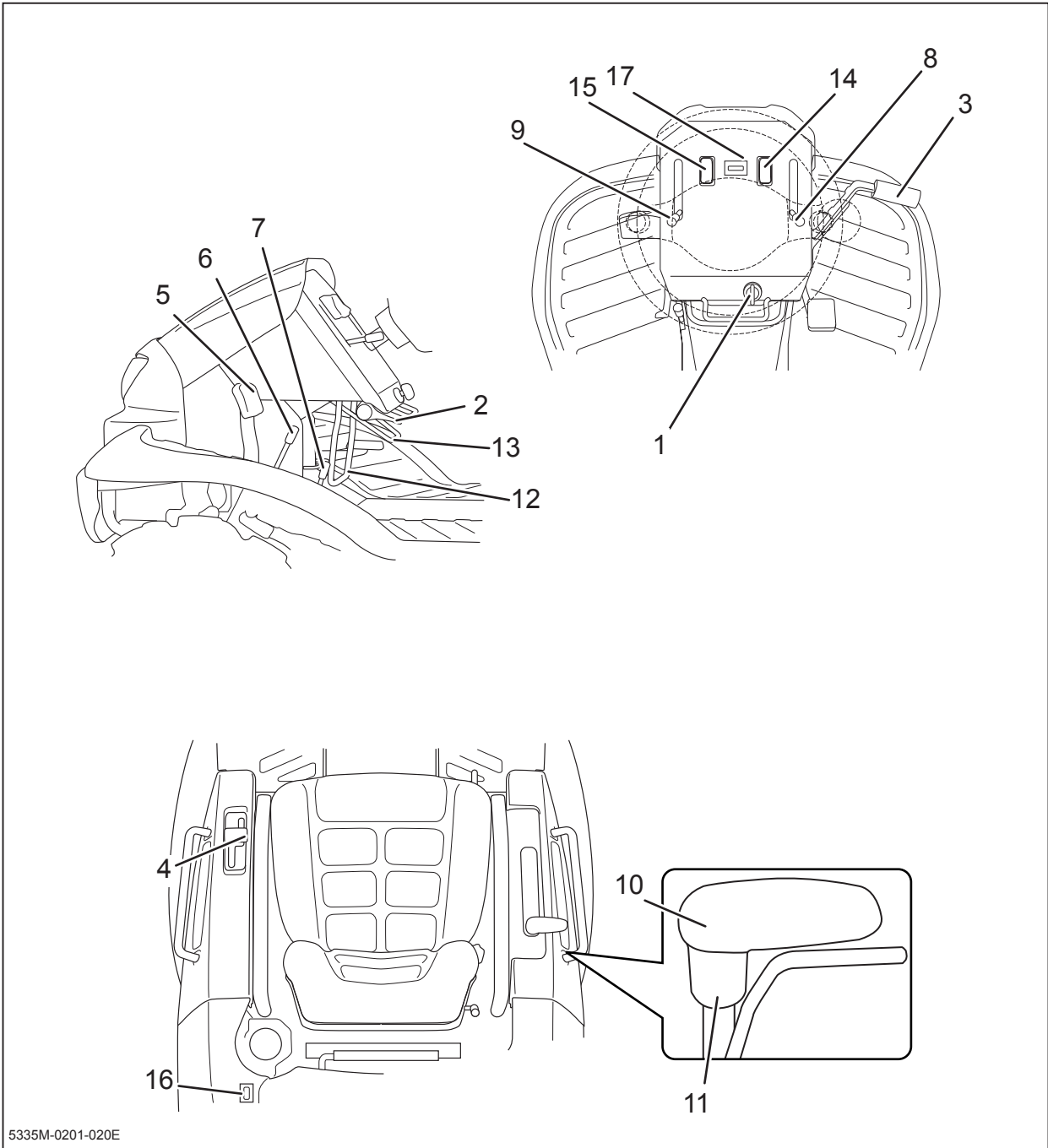

- 
- 1 **Main Switch** ..... Main switch is used to start or stop engine.
  - 2 **Throttle Lever** ..... Throttle lever is used to control engine speed.
  - 3 **Drive Pedal** ..... Drive pedal is used to control the traveling direction and speed of the machine. Machine moves forward when the front of drive pedal is depressed and backward when the rear of drive pedal is depressed. Angle of drive pedal determines the speed.
  - 4 **Drive Lever** ..... Drive lever is used to control the traveling direction and speed of machine. Machine moves forward when lever is tilted forward and backward when lever is tilted backward. Angle of drive lever determines the speed. (On the right lever model, this lever is on the right -hand side. See illustration.)
  - 5 **Brake Pedal** ..... Brake pedal is used to stop machine. When brake pedal is depressed, drive lever returns to neutral position and brake is engaged. (On the right lever model, this lever is on the right -hand side. See illustration.)
  - 6 **Parking Brake Lock Lever** ..... Parking brake lock lever is used when parking machine securely. Pulling parking lock lever while brake pedal is depressed locks brake pedal. (On the right lever model, this lever is on the right -hand side. See illustration.)
  - 7 **Auxiliary Transmission Shift Lever** ... Auxiliary transmission shift lever is used to shift auxiliary transmission to change the speed of the machine.
  - 8 **2WD/AWD Shift Lever (on CMX227and CMX186)** .... 2WD/AWD shift lever is used to switch between 2WD (rear-wheel drive) and AWD (all-wheel drive) modes.
  - 9 **Differential Lock Lever** ... Differential lock lever is used to lock differential when rear wheels slip. Tilting differential lock lever to [ON] position locks differential.

## 2

# Controls and Components

---

- 10 Cutting Height Adjust . . . . . Lever** Cutting height adjust lever is used to adjust the cutting height. Grab and hold cutting height adjust lock and move cutting height adjust lever back or forth to adjust cutting height.
- 11 Cutting Height Adjust Lock**
- 12 Cutting Rotary Clutch . . . . . Lever** Cutting rotary clutch lever is used to start or stop rotating cutting rotary.
- 13 Tilt Lever . . . . .** Tilt lever is used to adjust the angle of steering wheel.
- 14 Head Lamp Switch . . . . .** Head lamp switch is used to turn on or off head lamp. When umain switch is on, head lamp switch illuminates.
- 15 Tail Lamp Switch . . . . . (CMX227 Only)** Tail lamp switch is used to turn on or off tail lamp. When umain switch is on, head lamp switch illuminates.
- 16 Fuel Gauge . . . . .** Fuel gauge indicates the amount of fuel in fuel tank.
- 17 Hour Meter . . . . .** Hour meter indicates the cumulative total operating time of the machine in 0.1 hour increments.

## Product Specifications

### ⚠ CAUTION!

· Use this product properly after understanding its specifications thoroughly.

| Model and Type   |                        |                 | CMX227                             | CM226     | CXM186             | CM185     |  |
|------------------|------------------------|-----------------|------------------------------------|-----------|--------------------|-----------|--|
| Machine Mass     | kg                     |                 | 345                                | 325       | 325                | 320       |  |
| Mowing Rate      | m <sup>2</sup> /h      |                 | 7300* <sup>1</sup>                 |           | 7000* <sup>1</sup> |           |  |
| Dimensions       | Overall Length         | mm              | 1947 [1997]* <sup>2</sup>          |           | 1947               |           |  |
|                  | Overall Width          | mm              | 1020                               |           |                    |           |  |
|                  | Overall Height         | mm              | 860 [905]* <sup>3</sup>            |           | 840                |           |  |
|                  | Wheelbase              | mm              | 1300                               |           |                    |           |  |
|                  | Tread                  | Front           | mm                                 | 860       |                    |           |  |
|                  |                        | Rear            | mm                                 | 800       |                    |           |  |
| Ground Clearance | mm                     | 130             |                                    | 110       |                    |           |  |
| Engine           | Model                  |                 | Robin EH65DS                       |           | Robin EH63DS       |           |  |
|                  | Type                   |                 | Air-cooled 4-cycle V-twin Gasoline |           |                    |           |  |
|                  | Cylinder (Bore×Stroke) | mm              | 80X65                              |           |                    |           |  |
|                  | Displacement           | cm <sup>3</sup> | 653                                |           |                    |           |  |
|                  | Maximum Output         | kw(PS)/rpm      | 16.4(22)/3600                      |           | 13.4(18.3)/3600    |           |  |
|                  | Maximum Torque         | N·m(kgf·m)/rpm  | 45.6(4.65)                         |           | 43.3(4.42)         |           |  |
|                  | Starter System         |                 | Electric                           |           |                    |           |  |
|                  | Fuel                   |                 | Automotive Unleaded Gasoline       |           |                    |           |  |
|                  | Fuel Consumption       | g/kW·h(g/PS·h)  | 310(230)                           |           |                    |           |  |
|                  | Fuel Tank Capacity     | L               | 20                                 |           |                    |           |  |
|                  | Ignition               |                 | Contactless Magneto                |           |                    |           |  |
|                  | Spark Plug             |                 | NGK BPR5ES                         |           |                    |           |  |
| Electrical       | Battery Type           |                 | 38B19R                             |           |                    |           |  |
|                  | Battery Capacity       | V/Ah            | 12/28                              |           |                    |           |  |
| Performance      | Speed                  | High            | km/h                               | 0 to 13.8 |                    | 0 to 12.8 |  |
|                  |                        | Low             | km/h                               | 0 to 7.7  |                    | 0 to 7.2  |  |
|                  | Minimum Turning Radius | m               | 1.8                                |           |                    |           |  |
|                  | Gradeability           | Degrees         | 25                                 | 15        | 25                 | 15        |  |
|                  | Stability Angle        | Left            | Degrees                            | 30        |                    |           |  |
| Right            |                        | Degrees         | 30                                 |           |                    |           |  |

\*1 Estimated at the maximum speed with the auxiliary transmission in Low position (7.5km/h)

\*2 [ ] indicates the Step Bumper model

\*3 [ ] indicates the Extra Seat model



# 3

# Specifications

| Model and Type |                        |       | CMX227                      | CM226                                   | CMX186 | CM185            |  |
|----------------|------------------------|-------|-----------------------------|---|--------|------------------|--|
| Drive Train    | Main Transmission      |       | HST (Continuously Variable) |   |        |                  |  |
|                | Auxiliary Transmission |       | Constant Mesh               |   |        |                  |  |
|                | Tires                  | Left  |                             | AGR 4.00-7 (2PR)                        |        | AGR 3.50-7 (2PR) |  |
|                |                        | Right |                             | 17X8.00-8 (4PR)                         |        | 16X7.00-8 (4PR)  |  |
|                | Steering               |       | mm                          | Rack and Pinion<br>Round Steering Wheel |        |                  |  |
|                | Brakes                 |       |                             | Internally Expanding                    |        |                  |  |
| Cutting System | Cutting Width          |       | mm                          | 975                                     |        |                  |  |
|                | Cutting Height         |       | mm                          | 0~150 (21 Steps)                        |        | 0~130 (21 Steps) |  |
|                | Blade Type             |       |                             | Free Knife & Stepped Stay               |        |                  |  |
|                | Number of Blades       |       |                             | 2                                       |        |                  |  |
|                | Blade Drive Train      |       |                             | Shaft Drive                             |        |                  |  |

\*These specifications are subject to change without notice.

## Contents of Tool Bag

| No. | Content                          | Quantity | Note                 |
|-----|----------------------------------|----------|----------------------|
| 1   | Operator's Manual                | 1        | This Manual          |
| 2   | Operator's Manual for the Engine | 1        |                      |
| 4   | Engine Service Tool              | 1        | for Servicing Engine |

## Preparation

### Pre-start up Inspection

Always perform an inspection before use.

Refer to the **Maintenance Schedule** (page 40) for the inspection schedule and procedure.

### Checking and Filling Fuel

#### **⚠ WARNING!**

- Keep fire and spark away when handling fuel.
- Always stop engine before refueling.
- Do not fill beyond the limit (bottom of the filler filter) so that fuel will not overflow. In case fuel is spilt, wipe out immediately.

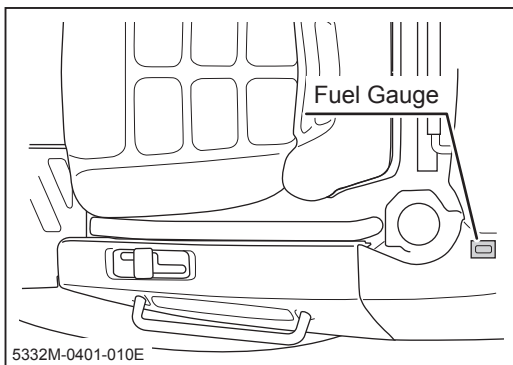

1. Check fuel gauge. If fuel level is low, fill fuel.

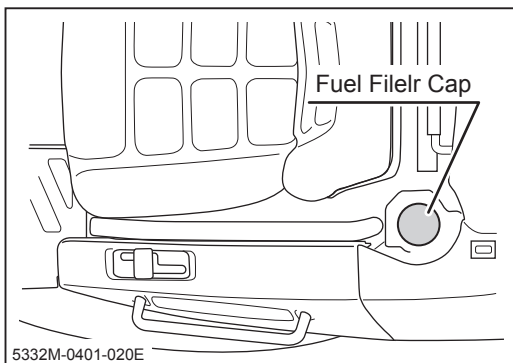

2. Open fuel filler cap and fill fuel.

3. Put fuel filler cap back in place and close it securely.

#### **NOTE**

- Fuel : Automotive Unleaded Gasoline
- Fuel Tank Capacity : 20L

## Adjusting Steering Wheel

### ⚠ CAUTION!

- After adjusting steering wheel, try moving steering wheel back and forth and up and down to make sure it is securely locked in its position.

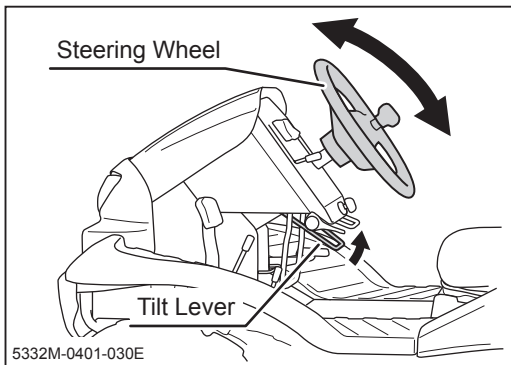

### Adjusting Angle (Tilting)

1. Pull up tilt lever to adjust steering wheel angle.
2. There are five positions for steering wheel angle.
3. After adjusting angle, return tilt lever to lock steering wheel securely.

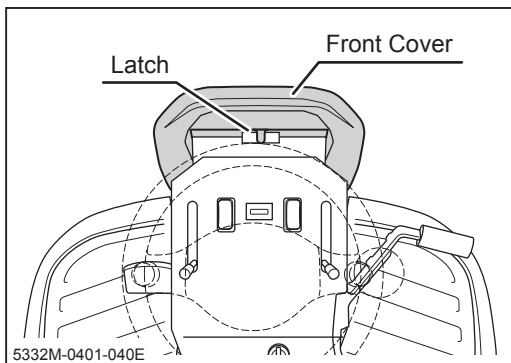

### Adjusting Height

1. Pull top edge of front cover to unlock latch.

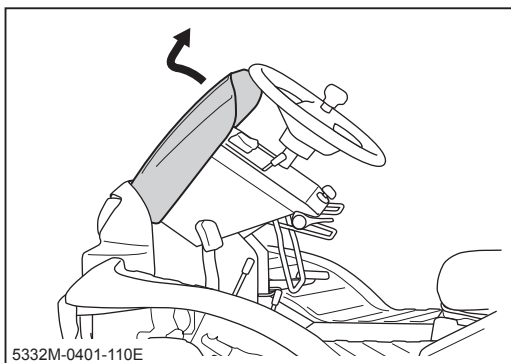

2. Pull out front cover.

### NOTE

- Inside of the front cover is made as tool box. Use this box to store items such as tools or substitute cutting blades.

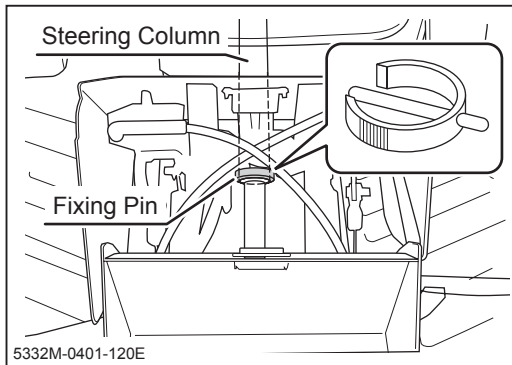

3. Remove fixing pin from steering column in the front of machine.

### NOTE

- If fixing pin is in the difficult direction to remove, steer the steering wheel to change direction of the pin so that the pin can be easily removed.

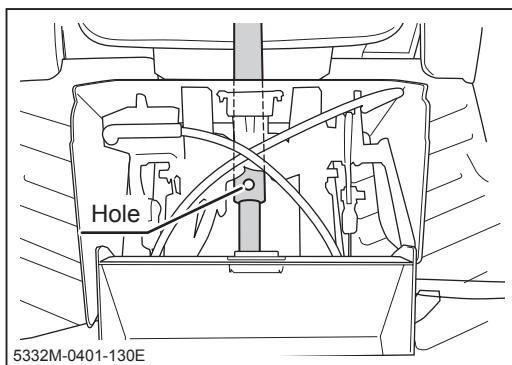

4. Adjust steering wheel height in preferred position. Line up holes on steering shafts and insert pin.

### NOTE

- Move steering wheel up and down to check if the steering wheel is fixed securely.

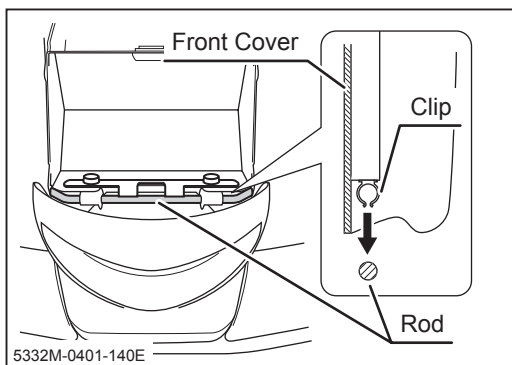

5. Raise steering wheel angle.
6. Fit clip on back side of front cover into the rod.
7. Latch top edge of the front cover.

### NOTE

- Pay attention not to catch the front cover by the plate on both sides when installing front cover.

## Adjusting Seating Position

### ⚠ CAUTION!

- Beware of pinch points when adjusting seating position.
- After adjusting seat, try moving seat back and forth and up and down to make sure it is securely locked in its position.

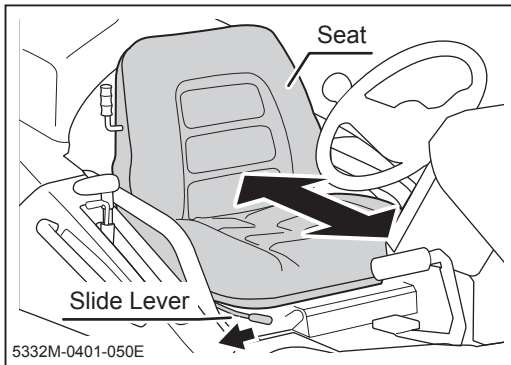

### Sliding seat

1. Pull slide lever to the right to slide seat forward or backward.
2. When seat is in a desired position, release slide lever and lock seat securely.

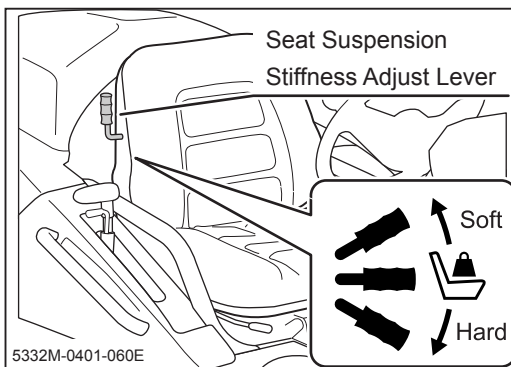

### Adjusting Stiffness

1. Move seat suspension stiffness adjust lever to adjust desired seat stiffness.

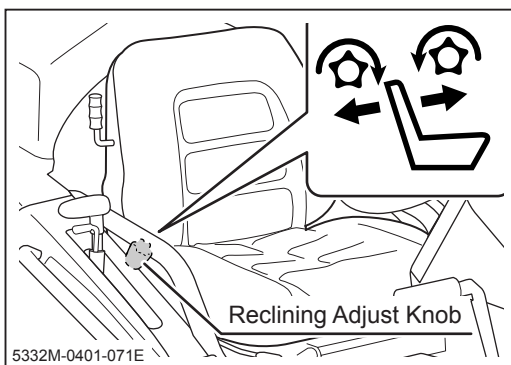

### Adjusting Reclining Angle

1. Rotate reclining adjust knob on the right of seat to adjust reclining angle of the seat.

### NOTE

- Do not adjust seat position to the end and recline the seat. The seat may contact with rear cover. This may activate seat switch and stop engine. Adjust seat in the range of not contacting with rear cover.

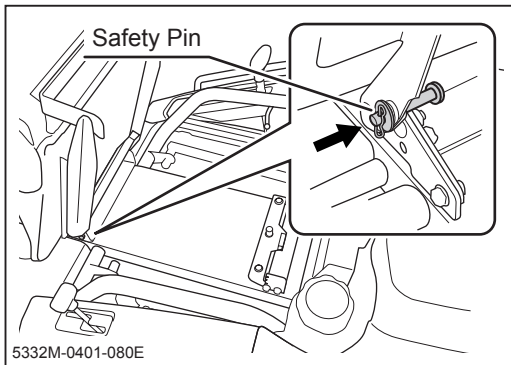

## Adjusting Height (Rear Part)

1. Slide seat to the rear-most position.
2. Pull up seat and push safety pin toward inside to hold seat lifted.

### NOTE

- Move seat and to check if the seat is locked securely.
- Height can be adjusted in 4 levels.

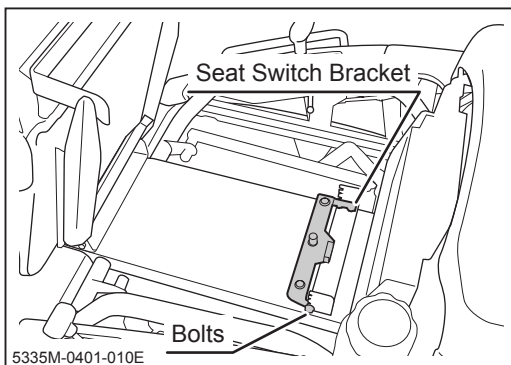

3. Remove 2 bolts fixing seat switch bracket.
4. Move seat switch bracket into desired position and fix with bolts firmly.
5. Pull safety pin back and lower the seat.

## Adjusting Height (Front Part)

If the seat height is not high enough with the rear part of seat in the highest position, adjust height of front the part of seat.

1. Pull up seat and push safety pin toward inside to hold seat lift up.
2. Adjust seat switch bracket in the highest position.

### NOTE

- Seat switch bracket need to be in the highest position when adjusting height of front part of seat.

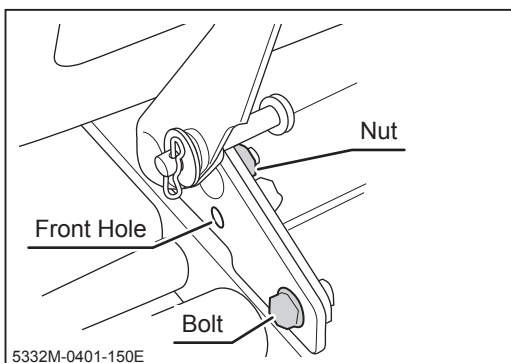

3. Loosen nut (left and right) fixing hinge of seat.
4. Remove bolts on both sides.
5. Move seat so that front hole lines up with bolt hole and fix with bolt on both sides.
6. Tighten nuts.
7. Pull safety pin back and lower the seat.

## Adjusting Drive Pedal

### ⚠ CAUTION!

- Always check if the drive pedal is fixed firmly after adjusting.

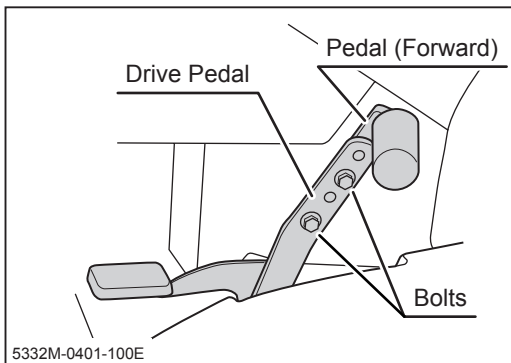

1. Remove two bolts fixing forward pedal with drive pedal.
2. Adjust the pedal (forward) into the desired position and fix with bolts.

### NOTE

- Drive pedal can be adjusted in 3 positions and angle.



## Driving

### Starting

### ⚠ WARNING!

- Always start and run engine in a well ventilated place.
- Always stay on seat when starting engine. Never attempt to start engine away from machine. Run over accident may result.

## **⚠ CAUTION!**

- Do not turn main switch to [  (start)] position when engine is running. Starter motor and/or engine may be damaged.
- Position throttle lever to [  (slow)] when starting.
- Do not turn the starter for more than 5 seconds. If the engine does not start, turn main switch back to [  (off)] position and wait for 10 seconds or more before attempting to start again.
- If engine does not start after starting procedure is performed several times, turn off main switch and wait for 5 to 10 minutes and try again.
- Do not use this machine in temperatures above 40°C or below -15°C. This machine cannot perform adequately in these temperature ranges. Using this machine under such conditions may result in an accident or cause damage to machine.
- In the winter or cold climate, warm up engine thoroughly before driving machine. A cold engine delivers poor performance, which may result in an accident. It also causes excessive wear.
- Do not use this machine in dusty places such as desert. Dust may clog air cleaner or enter engine, which may result in loss of performance and an accident. It also causes excessive wear.
- Do not use this machine in the altitude above 1500m (4920ft.) in its original configuration. This machine cannot perform adequately above that altitude. Using this machine under such conditions may result in an accident or cause damage to machine. If you need to use this machine above that altitude, contact your CANYCOM representative.



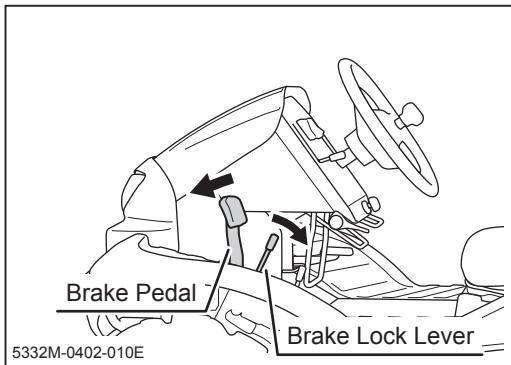

1. Make certain brake pedal is depressed and locked. If it is not, depress brake pedal and pull lock lever to lock it.

**NOTE**

- **Safety feature: engine cannot be started unless brake pedal is depressed.**

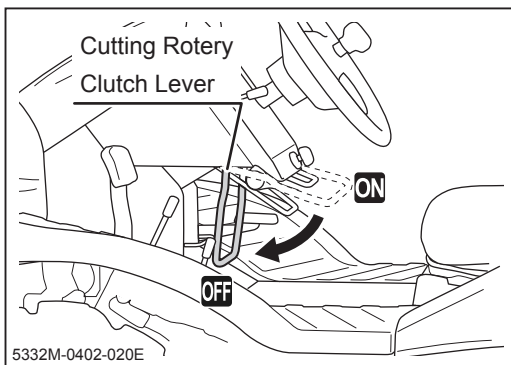

2. Make sure cutting rotary clutch lever is in [OFF] position.

**NOTE**

- **Safety feature: engine cannot be started unless cutting rotary clutch lever is in [OFF] position.**

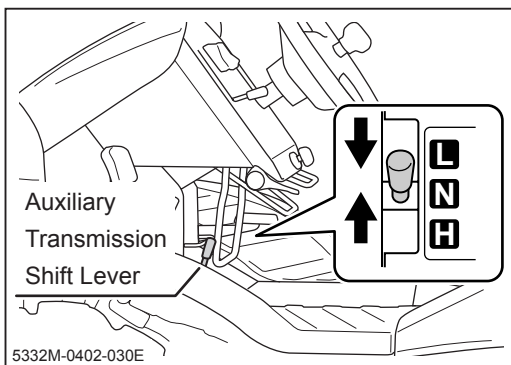

3. Make certain auxiliary transmission shift lever is in [N (neutral)] position.

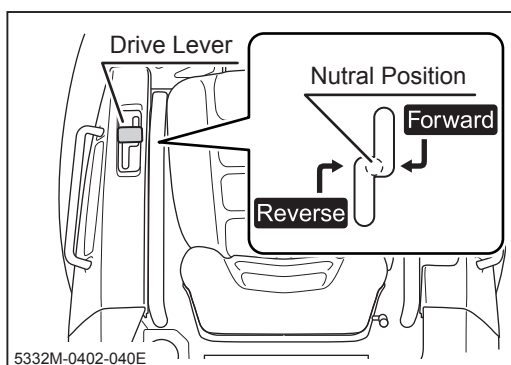

4. Make certain drive lever is in neutral position.

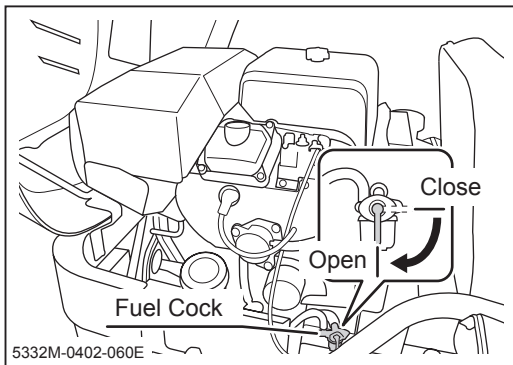

**NOTE**

- **Drive lever returns to neutral position when brake pedal is fully depressed.**

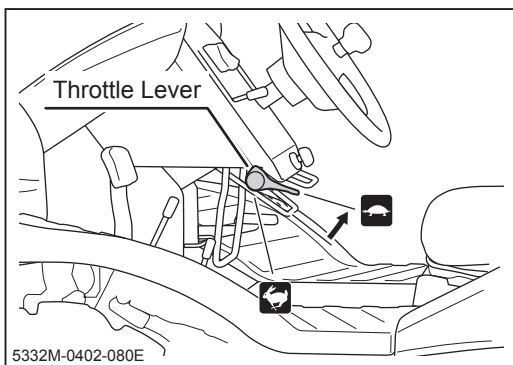

5. Open engine hood (see page 51). Open fuel cock.





6. Make sure throttle lever is in the [  (slow)] position. In the cold weather below 10 degrees celsius when engine revolution is not stable, position throttle lever 1/3 toward the [  (fast)] position.

## NOTE

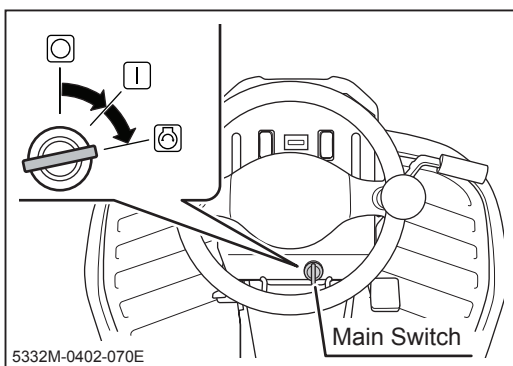
- This machine is equipped with the auto-choke system and may start more easily with throttle lever in the [  (slow)] position.



7. Insert ignition key into main switch.
8. Turn key to [  (start)] position to start engine. Release key immediately after engine starts. Key automatically returns to [  (ON)] position.
9. Run engine without load for about 5 minutes to warm up.

## NOTE

- Avoid frequent starting. Once engine starts, run it for a while to charge battery.
- Drive machine gently in the first week (40 to 50 hours) of operation after purchase for breaking-in.

## Driving

### **⚠ WARNING!**

- Always wear protective footwear, long trousers, hardhat, safety glasses and ear protection when operating or servicing the machine. Proper clothing will minimize the chance of injury. Do not operate the equipment if you have long hair, loose clothing, or jewelry; all of which may get tangled in moving parts. Do not operate the machine barefoot or with open sandals.
- Do not allow bystanders to come near machine when driving.
- Always make certain of the safety of your surroundings before driving; start slow.
- Always make certain of the safety of your surroundings before turning
- Do not make sudden starts, acceleration, change of speed, change of direction, or stop. Do not turn at speed. Avoid sudden maneuvers; this may cause the operator to fall or to be thrown, or machine to tip over.
- Do not operate drive pedal and drive lever simultaneously.
- Do not turn the key to [○ (off)] position while traveling.

### **⚠ CAUTION!**

- Do not operate drive pedal or drive lever when brake is locked with parking brake lock lever. It can wear out brake.

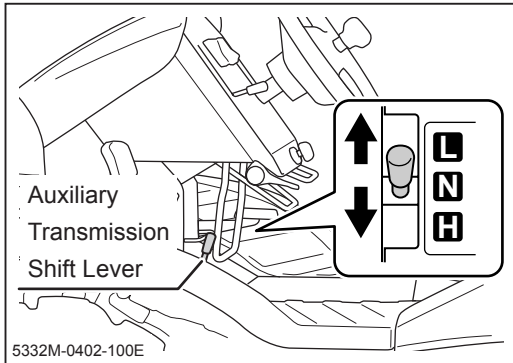

1. Make certain of the safety of your surroundings.
2. Move auxiliary transmission shift lever to either [H (high speed)] or [L (low speed)] position.

## NOTE

- See Specifications (page 15) for the speed range in either gear position.

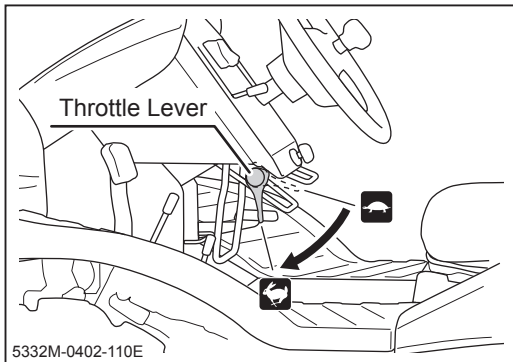

3. Move the throttle lever toward [  (fast)] position to increase engine speed.

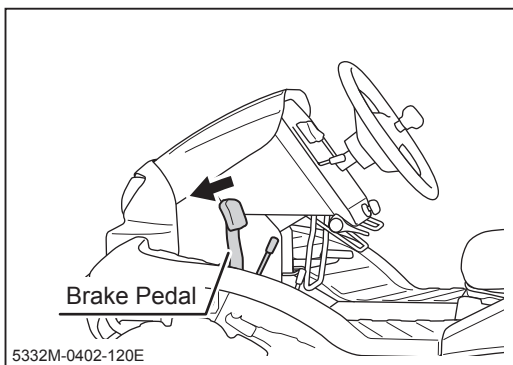

4. Depress brake pedal to release brake pedal lock.

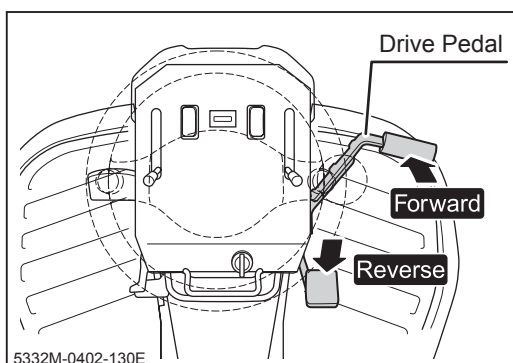

## Driving with Drive Pedal

5. Depress gradually the forward or reverse side of drive pedal to move in the corresponding direction.

## NOTE

- Speed can be adjusted continuously by the position of drive pedal.

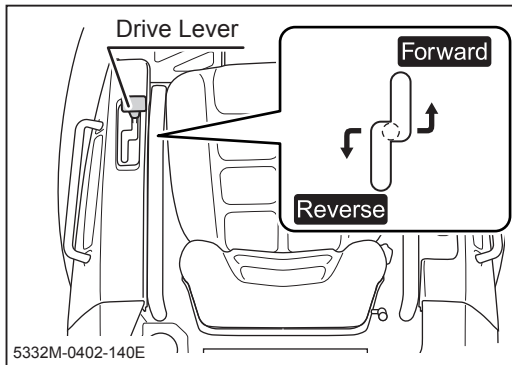

### Driving with Drive Lever

5. Move drive lever gradually forward or backward to move in the corresponding direction.

### NOTE

- Speed can be adjusted continuously by the position of drive lever.

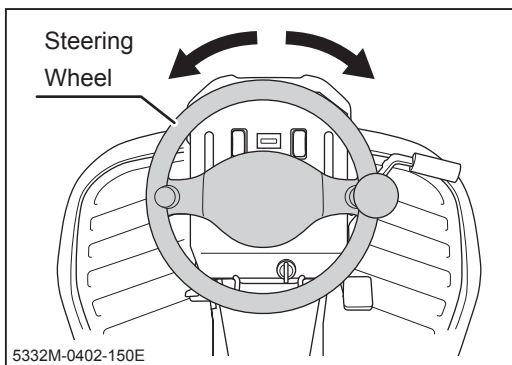

6. Turn steering wheel to turn.

## Stopping

### ⚠ WARNING!

- Do not make a sudden stop. Operator may be thrown off, or machine may skid or tip over.
- Always park on a firm, level place. Never park on a potentially dangerous place.

### ⚠ CAUTION!

- Do not hold drive lever and depress brake pedal at the same time. Or, do not depress drive and brake pedals at the same time. HST may be damage.

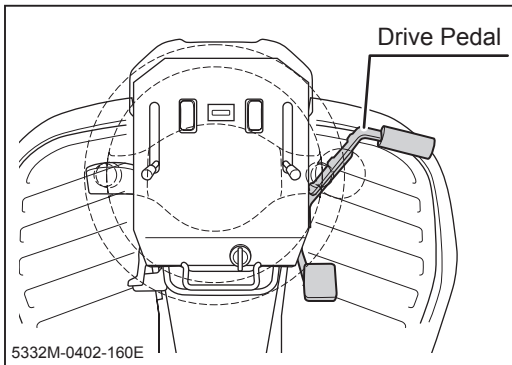

## When Driving with Drive Pedal

1. Gradually return drive pedal to slow down.
2. Take foot off drive pedal.

## NOTE

- Drive pedal automatically returns to neutral when released.

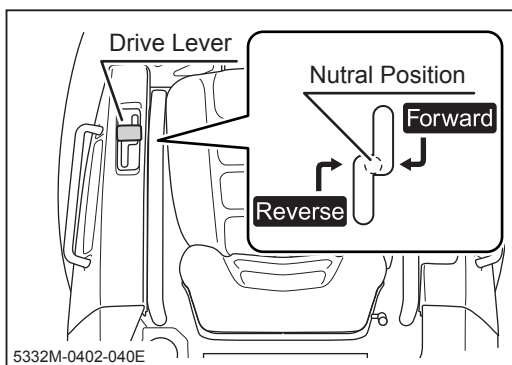

## When Driving with Drive Lever

1. Gradually return drive lever to neutral position to slow down.
2. Release hand off drive lever.

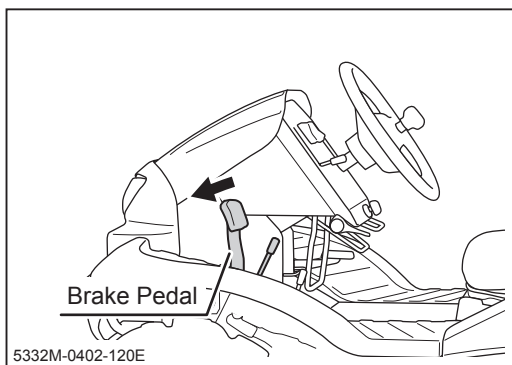

3. Depress brake pedal to stop machine completely.

## NOTE

- When brake pedal is depressed, drive lever returns to neutral position.

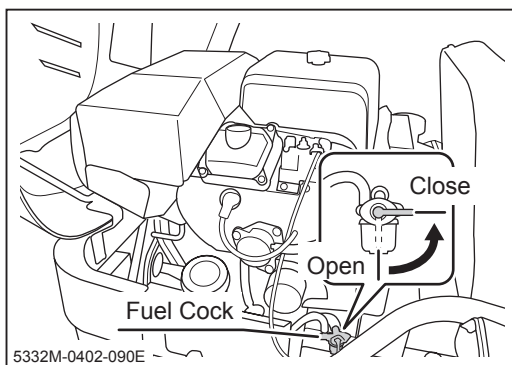

4. Open engine hood and close fuel cock. Close engine hood.

## Shifting

**⚠ WARNING!**

- Always shift gears firmly. When transmission is not firmly shifted, it may jump out of gear, resulting in loss of control of machine.

**⚠ CAUTION!**

- Always stop machine to shift gears. Shifting gears while machine is in motion can damage transmission.

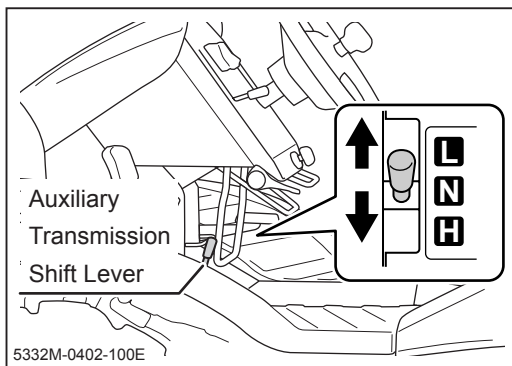

1. Stop machine.
2. Move auxiliary transmission shift lever to [H (high speed)] or [L (low speed)] position firmly.

**NOTE**

- See Specifications (page 15) for the speed range in either gear position.

## Shifting Between 2WD and AWD (CMX227 and CMX186)

**⚠ CAUTION!**

- Always stop machine to shift between 2WD or AWD (all-wheel-drive) modes. Shifting gears while machine is in motion can damage transmission.
- Use 2WD mode under normal condition.
- Pay attention to the minimum turning radius in AWD mode. In AWD mode, minimum turning radius is greater than that in 2WD mode.

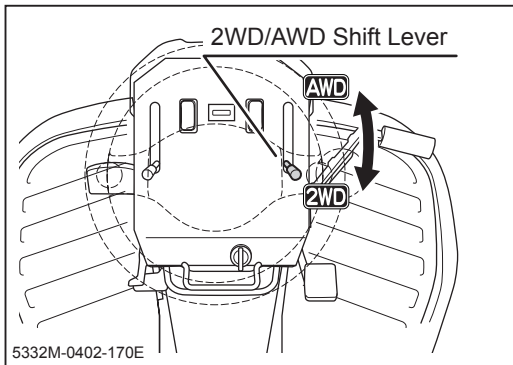

1. Stop machine.
2. Move 2WD/AWD shift lever to [2WD] or [AWD] position firmly.

## Locking Differential

Differential can be locked to minimize slipping o slippery surface.

### ⚠ CAUTION!

- Always stop machine to operate differential lock lever. Operating differential lock lever while machine is in motion can damage differential.
- Keep differential lock in [OFF] position under normal running condition. Differential may be damaged.
- Do not turn machine when differential lock is in [ON] position.

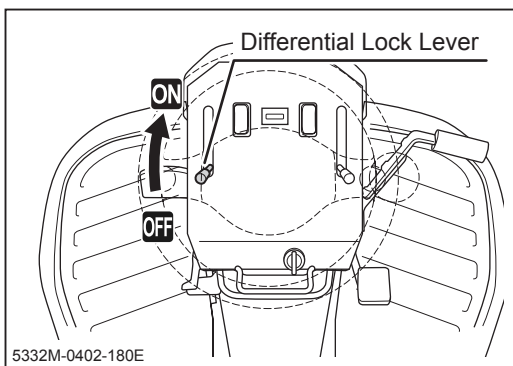

1. Move differential lock lever to [ON] position.
2. Move auxiliary transmission shift lever to [L (low speed)] position.
3. Drive slowly out of the slippery area.



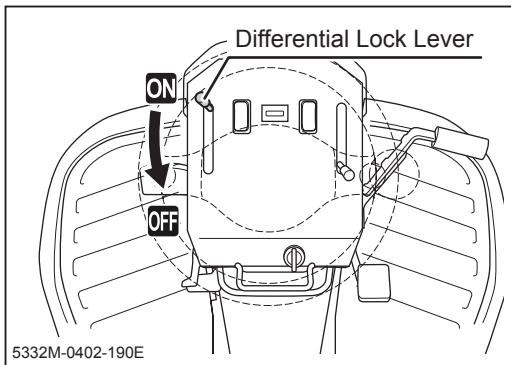



- Once machine is out of the slippery area, stop and move differential lock lever to [OFF] position.

## Parking

### ⚠ WARNING!

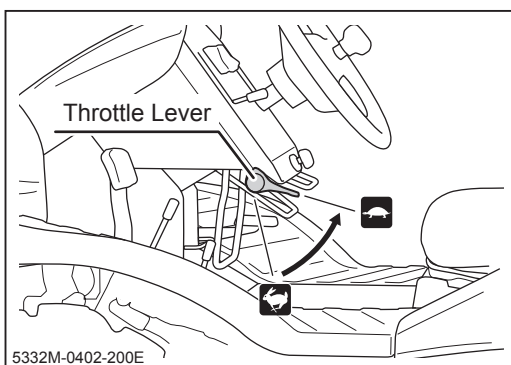
- Always park on a firm, level place. Never park on a potentially dangerous place.
- Avoid parking on a slope. Never park on a slope with an incline of 10 degrees or steeper. If it is absolutely necessary to park machine on a slope less than 10 degrees, make certain to apply parking brake firmly and block wheels with chocks.
- Apply brake and remove key when parking.
- Do not park near combustibles.



- Stop machine.
- Move throttle lever toward [  (slow)] to slow engine speed.

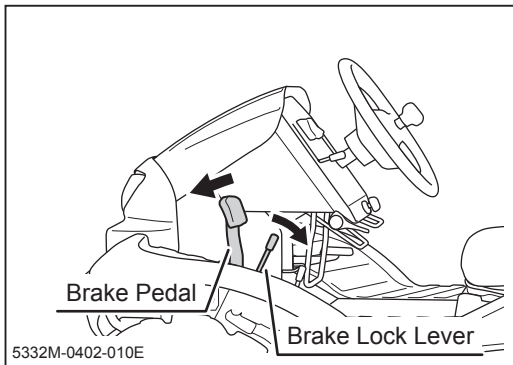

3. Depress brake pedal and pull brake lock lever to lock brake pedal in depressed position.

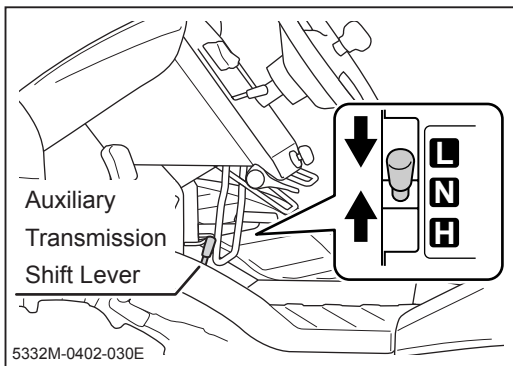

4. Move auxiliary transmission shift lever to [N (neutral)] position.

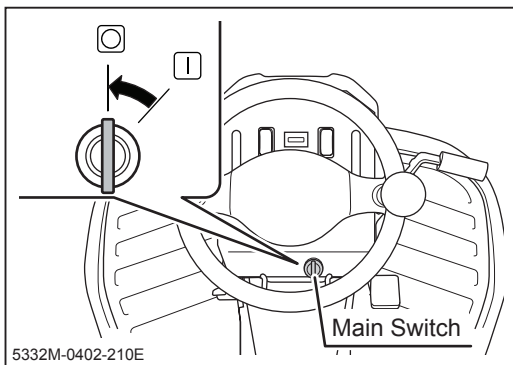

5. Turn main switch to [O (off)] to stop engine. Remove ignition key.

## Working

### Inspecting Cutting Blade

Inspect cutting blade before work. Refer to **Cutting Blades** (page 65) for inspection procedure.

### Adjusting Cutting Height

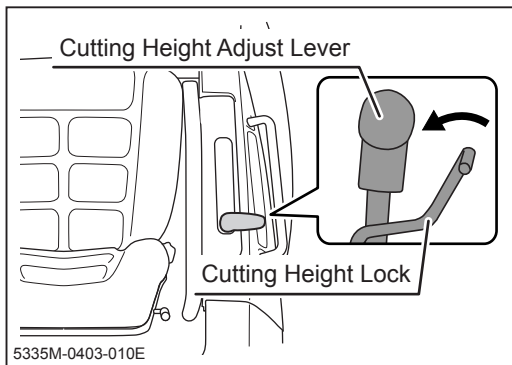

1. Grab cutting height lock to unlock cutting height adjust lever.

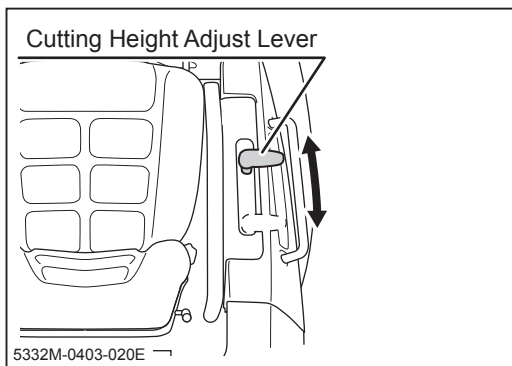

2. With lock button pulled up, move cutting height adjust lever to a desired position.
3. Release lock to lock cutting height adjust lever.

#### NOTE

- **Cutting Height Range: 0mm - 150mm (CMX227, CM226)**  
0mm - 130mm (CMX186, CM185)
- **Cutting Height indicated on the side of the adjust lever is for reference purpose only; actual cutting height may vary due to the condition of ground or brush, and other factors.**

## Cutting

### **DANGER!**

- Never place any part of body under cutting blade shield.

### **WARNING!**

- Always wear protective footwear, long trousers, hardhat, safety glasses and ear protection when operating or servicing the machine. Proper clothing will minimize the chance of injury. Do not operate the equipment if you have long hair, loose clothing, or jewelry; all of which may get tangled in moving parts. Do not operate the machine barefoot or with open sandals.
- Do not allow bystanders to come near machine when cutting.
- Rotating cutting blades can throw stones or debris and cause injuries and damages to nearby people, animals, crops, buildings, automobiles, etc. Pay attention to the safety of surroundings and plan ahead when cutting.
- Never attempt to cut with cutting blade shield open.
- When cutting, drive forward. Machine is intended to cut brush while moving forward, and this best prevents stones and debris from being thrown.
- Turn cutting rotary clutch to [ON] only when cutting. Keep it in [OFF] position all the other times.
- Never attempt to cut brush on the edge of a ditch or bank. Shoulder of the ditch or bank may collapse. Pay special attention after heavy rain or earthquake.

## **⚠ WARNING!**

- Inspect the work site beforehand; inspect terrain and locate holes, drops, or obstacles. Also inspect overhead obstacles such as the branches of a tree. Pay special attention when working near these areas.
- Do not use this machine on an incline steeper than 25 degrees for the CMX 227/CMX186 or 15 degrees for the CM226/CM185.
- Always stay on machine when working.
- Make sure air intake for cooling is not clogged or blocked. If it is clogged or blocked, it causes overheating, resulting in damages to machine.

## **⚠ CAUTION!**

- When working in a dusty area, clean air cleaner element twice a day. Dirty air cleaner element results in poor starting, poor performance, or short life.
- When a cutting blade is broken, replace it and the other blade with a new pair. A broken blade causes excessive vibration, which damages machine.
- When something is tangled to cutting blade, stop engine immediately and remove the tangled object. Such object causes excessive vibration, which damages machine.
- Always clean cutting blades and cutting blade stay after every use ( see page 75). Remained foreign object may solidified or corrode and make cutting blades hard to remove.

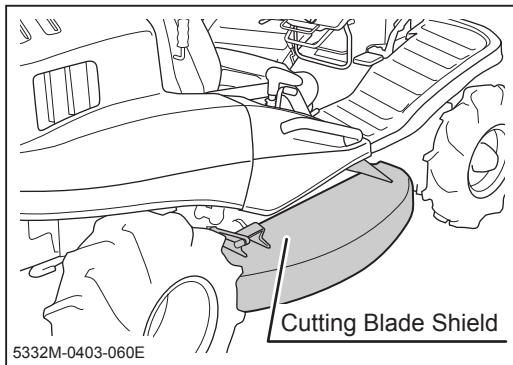

1. Make sure cutting blade shield is closed.

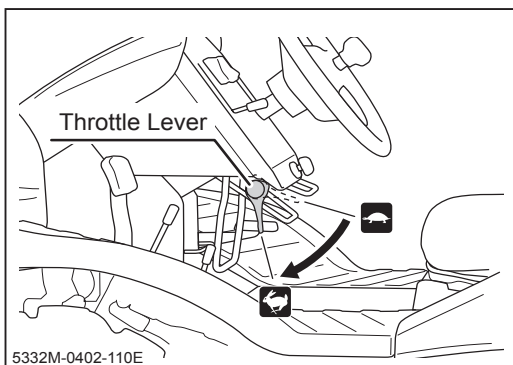

2. Turn throttle lever to [  (fast)] position to raise engine speed.

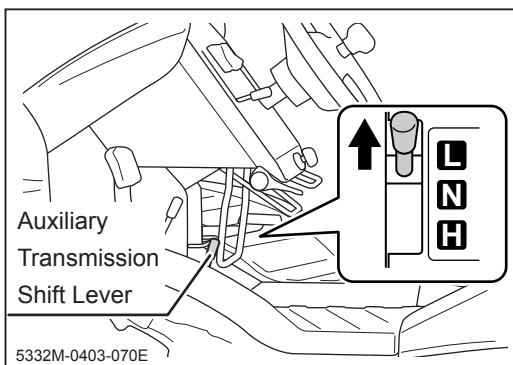

3. Move auxiliary transmission shift lever to [L (low speed)].

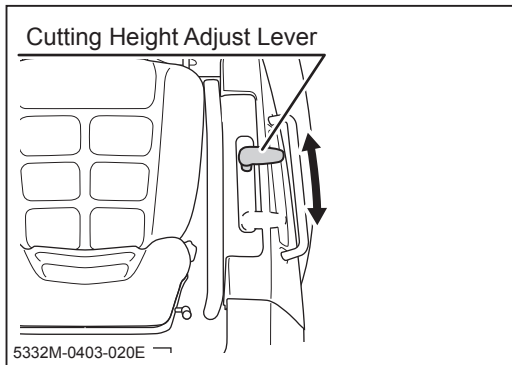

4. Move cutting height adjust lever to a desired height.

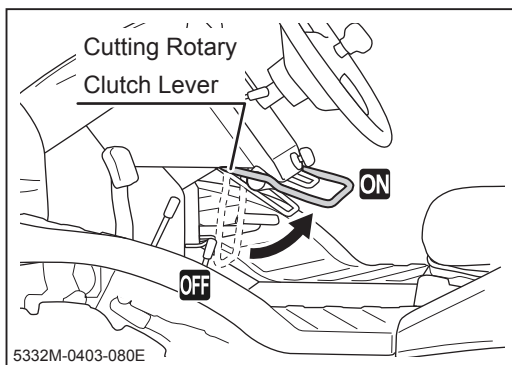

5. Move rotary clutch lever to [ON] to start cutting blade.

### NOTE

- **Safety feature:** engine stops automatically if operator leaves seat while cutting blade is rotating.

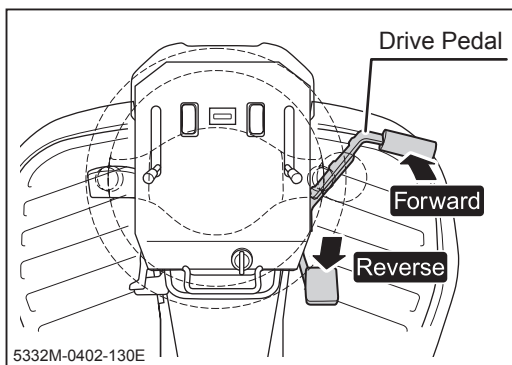

6. Drive machine forward to cut.

### NOTE

- **When cutting with this machine for the first time, start on a flat surface. Drive slowly and in an overlapping pattern.**
- **If load to cutting blade is high, drive slowly, or cut twice.**

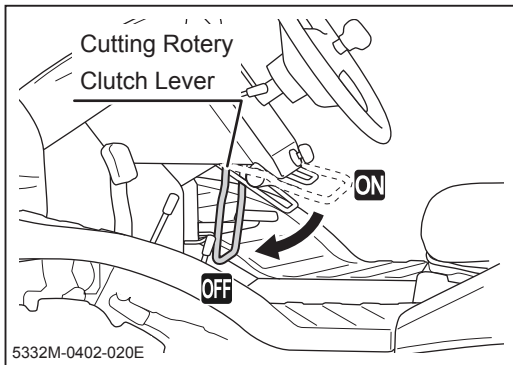

7. Move cutting rotary clutch lever to [OFF] to stop cutting blade.

## NOTE

- Moving cutting rotary clutch lever to [OFF] applies brake on cutting blade to stop.

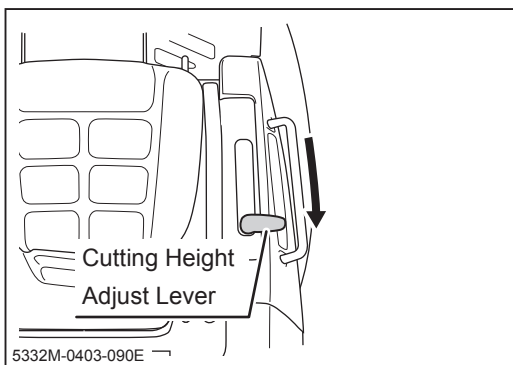

8. Move cutting height adjust lever to the highest position.



## Adjusting Cutting Blade Shield

### **⚠ WARNING!**

- Always stop engine when adjusting cutting blade shield. It may cause serious injury if you open cutting blade shield when blades are rotating.
- Never attempt to work if cutting blade is unlocked. Also never attempt to work if cutting blade shield is open upward. Thrown stones or debris may cause injuries to nearby people.

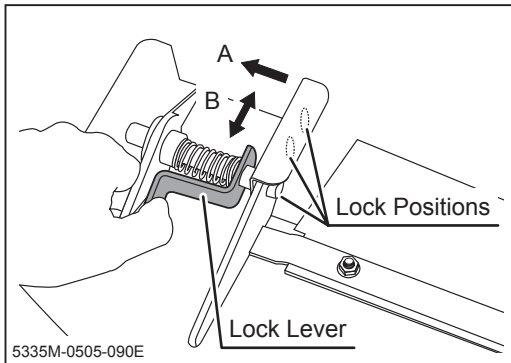

### Opening shield to the side

1. Squeeze lock lever as shown (A).
2. Keep lock lever squeezed and move shield (B) to one of three lock positions.
3. Release lock lever at the selected lock position so that the pin on lock lever positively fits into the hole at lock position.

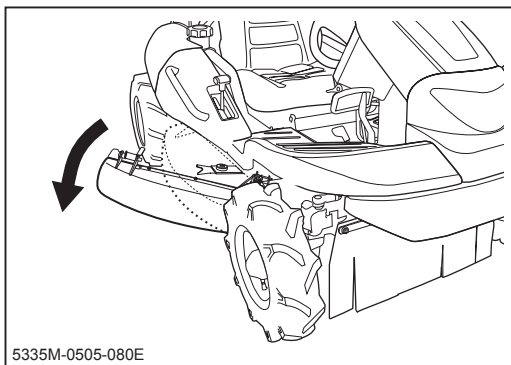

## Maintenance Schedule

### **⚠️WARNING!**

- Follow the scheduled maintenance as described below. Failure to do so may result in mechanical or property damage, injury or death.

## Engine

### Daily Inspection

- Engine Oil - to be clean and at the correct level.
- Air Cleaner Element - to be clean and free of damage.
- Leaks - No fuel or oil leaks to be found.
- Bolts, Nuts, Fasteners - not to be loose or missing.
- Sound, Vibration - No abnormal noise or excessive vibration.

### Scheduled Maintenance

| Items                                    | Frequency  |
|--|--|
| Clean and check fastenrs                 | Every 8 hours (daily)<br>(clean more frequently in dusty place)                            |
| Check and fill oil                       | Every 8 hours (daily)<br>(clean more frequently in dusty place)                            |
| Clean air cleaner element                | Every 8 hours (daily)<br>(clean more frequently in dusty place)                            |
| Change oil                               | First time:20 hours. Every 50 afterward  |
| Clean spark plugs                        | Every 100 hours  |
| Replace fuel strainer                    | Every 200 hours  |
| Replace air cleaner element              | Every 200 hours<br>(contact Canycom representative for placement)                          |
| Check and adjust spark plug gap          | Every 200 hours<br>(contact Canycom representative for placement)                          |
| Replace oil filter                       | First time:50 hours. Every 200 afterward<br>(contact Canycom representative for placement) |
| Check and adjust tappets                 | Every 300 hours (do more frequently in dusty place)  |
| Remove carbon deposit from cylinder head | Every 500 hours (do more frequently in dusty place)  |
| Clean Oil pan                            | Every 500 hours (clean more frequently in dusty place)                                     |
| Clean carburator                         | Every 500 hours (clean more frequently in dusty place)                                     |
| Perform valve lapping                    | Every 500 hours (clean more frequently in dusty place)                                     |
| Replace fuel hose                        | Every two years  |
| Overhaul                                 | 1000 hours (contact Canycom representative for overhaul)                                   |

**Chassis**

- Perform a pre-startup inspection (PSI) before each use, a monthly inspection once a month, and a yearly inspection once a year.
- Some maintenance procedures described below may require special knowledge or tools and instruments. Contact your CANYCOM representative to perform such procedures.

| Item  | Description                   | Schedule  |     |      | Note |         |
|---|-------------------------------|---|-----|------|------|---------|
|   |                               | PSI   | Mon | Year |      |         |
| <b>Drive Train</b>  | <b>Tires</b>                  | Tires shall be inflated to the specified pressure.  | √   | √    | √    | Page 59 |
|   |                               | Tires and wheels shall be free of crack, damage, or uneven wear.  |     | √    | √    |         |
|   |                               | Wheel bolts shall not be loose or missing.  | √   | √    | √    |         |
|   |                               | Wheel bearings do not exhibit excessive play and no irregular noise or overheating shall be observed.   |     | √    | √    |         |
|   | <b>Transmission</b>           | Irregular noise or overheating shall not be observed when moving forward or backward.                   |     | √    | √    |         |
|   |                               | There shall not be oil leaks in or around transmission.   |     | √    | √    |         |
|   | <b>Auxiliary Transmission</b> | Transmission can be shifted to either position positively and performs normally.                        |     | √    | √    |         |
|   |                               | Lever shall not be loose or have excessive play.  |     | √    | √    |         |
|   | <b>Front Axle</b>             | Irregular noise or overheating shall not be observed when traveling.                                    |     | √    | √    |         |
|   |                               | There shall not be oil leaks in or around front differential case or knuckles.                          |     | √    | √    |         |
|   | <b>HST</b>                    | HST shall perform normally.   | √   | √    | √    |         |
|   |                               | Hydraulic fluid shall be filled to a proper level and shall be clean and free of dirt or contamination. |     | √    | √    | Page 61 |
| Lever or pedal shall not be loose or have excessive play. |                               |   | √   | √    |      |         |

| Item                                 | Description  | Schedule  |     |      | Note |             |
|--------------------------------------|--|---|-----|------|------|-------------|
|                                      |  | PSI   | Mon | Year |      |             |
| <b>Drive Train</b>                   | <b>V-belt</b>  | Belt tension shall be properly adjusted.  |     | √    | √    |             |
|                                      |  | Belt shall be free of damage or excessive wear.   |     | √    | √    |             |
|                                      | <b>Brake</b>   | Brake shall work properly.  | √   | √    | √    | Page 64     |
|                                      | <b>Parking Brake</b>   | Parking brake shall be able to hold the machine on a 20-degree slope.                       |     | √    | √    |             |
|                                      | <b>Steering</b>  | Turn steering wheel right and left; front wheels shall turn accordingly.                    |     | √    | √    |             |
|                                      |  | Steering can be adjusted in 5 positions and locked securely.                                |     | √    | √    |             |
|                                      | <b>Rods, Links, and Wires</b>  | Rods, links, and wires in linkage shall be free of deformation or damage.                   |     | √    | √    |             |
|                                      |  | Connections shall be free of looseness, excessive play, or missing cotter pins.             |     | √    | √    |             |
| <b>Body, Chassis, Safety Devices</b> | <b>Chassis, Frame</b>  | Shall be free of cracks, deformation, or corrosion.   |     | √    | √    |             |
|                                      |  | Fastening bolts or nuts shall not be loose or missing.                                      | √   | √    | √    |             |
|                                      | <b>Body Panels</b>   | Shall be free of cracks, deformation, or corrosion.   |     | √    | √    |             |
|                                      |  | Doors and lids shall open, close, and lock properly.  |     | √    | √    |             |
|                                      |  | Fastening bolts or nuts shall not be loose or missing.                                      | √   | √    | √    |             |
| <b>Labels</b>                        | Warning labels and instruction plates shall be clean, legible, and free of damage. | √   | √   | √    |      |             |
| <b>Cutting System</b>                | <b>Cutting System</b>  | Blades shall be free of cracks or damage.   | √   | √    | √    | Page 65     |
|                                      |  | Blade mounting pins and wave washers shall be free of cracks or damage.                     | √   | √    | √    | Page 65     |
|                                      |  | Cutting blade shield shall be free of cracks or damage.                                     | √   | √    | √    |             |
|                                      |  | Skirts on cutting blade shield shall be free of cracks or damage, and shall not be missing. | √   | √    | √    |             |
|                                      |  | Belt tension shall be properly adjusted.  | √   | √    | √    | Page 68     |
|                                      |  | Belt shall be free of damage or excessive wear.   | √   | √    | √    | Page 68     |
|                                      |  | When activated, cutting blade brake shall stop cutting rotary.                              | √   | √    | √    | Page 69     |
|                                      |  | Greasing points shall be properly greased.  |     | √    | √    | Page 46, 47 |

# 5

# Maintenance

| Item                     | Description                       | Schedule  |     |      | Note |         |
|--------------------------|-----------------------------------|---|-----|------|------|---------|
|                          |                                   | PSI   | Mon | Year |      |         |
| <b>Electrical System</b> | <b>Charging System</b>            | Charging system shall charge battery.   |     |      | √    |         |
|                          | <b>Battery</b>                    | Battery fluid (electrolyte) shall be of proper level.                             |     | √    | √    | Page 70 |
|                          |                                   | Terminals shall be free of looseness or excessive corrosion.                      |     | √    | √    |         |
|                          | <b>Head Lamp<br/>Tail Lamp *1</b> | Head and tail lamps shall work.   | √   | √    | √    |         |
|                          |                                   | Lamp lens shall be free of cracks or chipping and water shall not be in the lamp. |     | √    | √    |         |
|                          | <b>Wiring</b>                     | Connections shall not be loose.   |     | √    | √    |         |
|                          |                                   | Wiring shall be free of damages.  |     | √    | √    |         |

\*1 CMX227 only.

## List of Fluids and Lubricants

| Item                          | Schedule   | Grade  | Cap.             |
|-------------------------------|--|--|------------------|
| Fuel                          | As needed.   | Automotive Unleaded Gasoline   | 20 L             |
| Engine Oil                    | Fill<br>Inspect daily. Fill as needed.<br>Change<br>Initially - After 20 hours of use.<br>Every 50 hours afterwards. | Gasoline Engine Oil<br>API rating: SE or better.<br>SAE rating: 10W-30 | 1.4L             |
| Transmission Oil              | Change<br>Initially - After 50 hours of use.<br>Every 500 hours afterwards.  | Gear Oil<br>API rating: GL-4 or 5<br>SAE rating: 80                    | 0.9L             |
| Front Axle Oil*1              | As needed.   | Gear Oil<br>API rating: GL-4 or 5<br>SAE rating: 80                    | 0.7L             |
| HST Fluid                     | As needed.   | Gasoline Engine Oil<br>API rating: SE or better.<br>SAE rating: 20W-30 | 4.0L*2<br>1.1L*3 |
| Cutting Rotary<br>Gearbox Oil | As needed.   | Gear Oil<br>API rating: GL-4 or 5<br>SAE rating: 80                    | 0.15L            |
| Battery Electrolyte           | Fill<br>Inspect every 50 hours and fill<br>when necessary.   | Distilled Water  | -                |

\*1 CMX227 and CMX186 only, \*2 Models with Charge-Pump, \*3 Models without Charge-Pump

## Greasing Points

### ⚠ CAUTION!

- Grease regularly. Insufficient greasing may result in seizure or rusting, affecting smooth operation of machine.

### NOTE

- When using a manual grease pump, push handle five to six times. When handle becomes heavy, stop pushing.
- When using a pneumatic grease pump, charge for two to three seconds.
- Set cutting rotary height to the lowest to grease link pivots.

## Greasing Points (CMX 227 / CMX 186)

| Location                     | Schedule       | Grade          |
|------------------------------|----------------|----------------|
| 1 Propeller shaft            | Every 6 Months | Chassis Grease |
| 2 Cutting rotary link pivots | Every 6 Months | Chassis Grease |
| 3 Cutting rotary drive shaft | Every 6 Months | Chassis Grease |

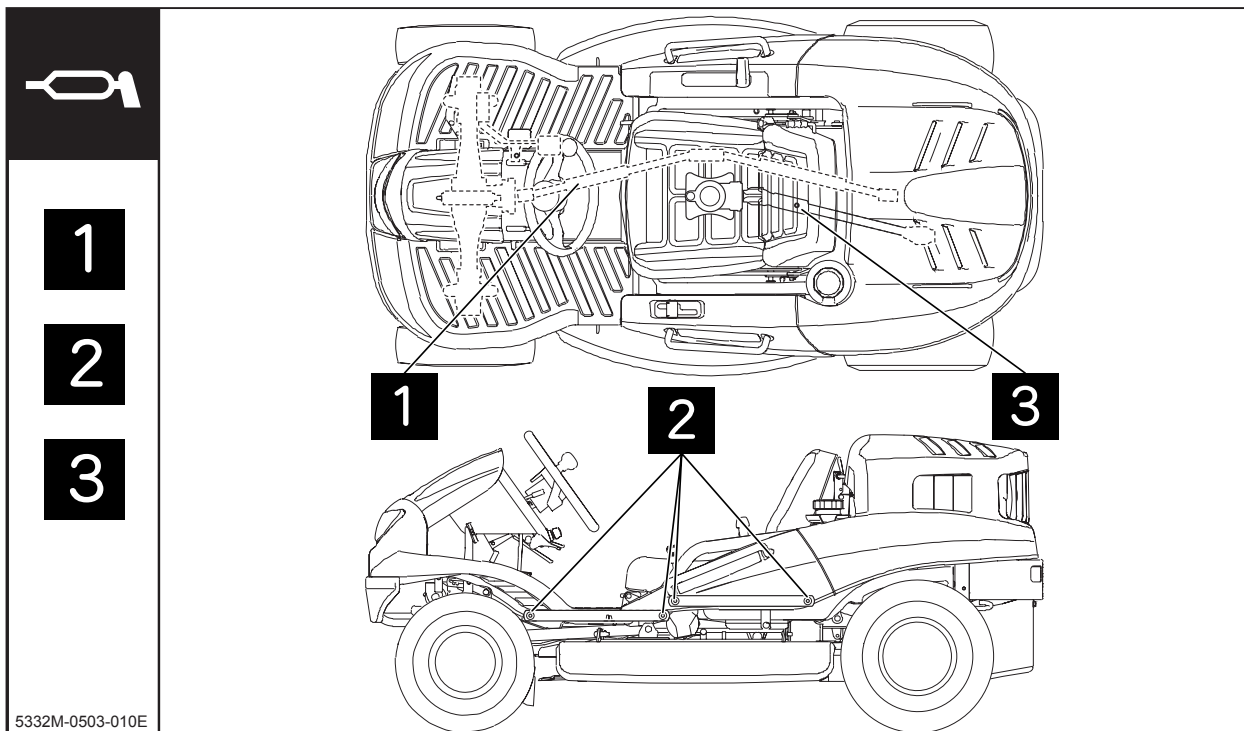

## Greasing Points (CM 226 / CM 185)

| Location                            | Schedule       | Grade          |
|-------------------------------------|----------------|----------------|
| <b>1</b> Front knuckles             | Every 6 Months | Chassis Grease |
| <b>2</b> Cutting rotary link pivots | Every 6 Months | Chassis Grease |
| <b>3</b> Cutting rotary drive shaft | Every 6 Months | Chassis Grease |

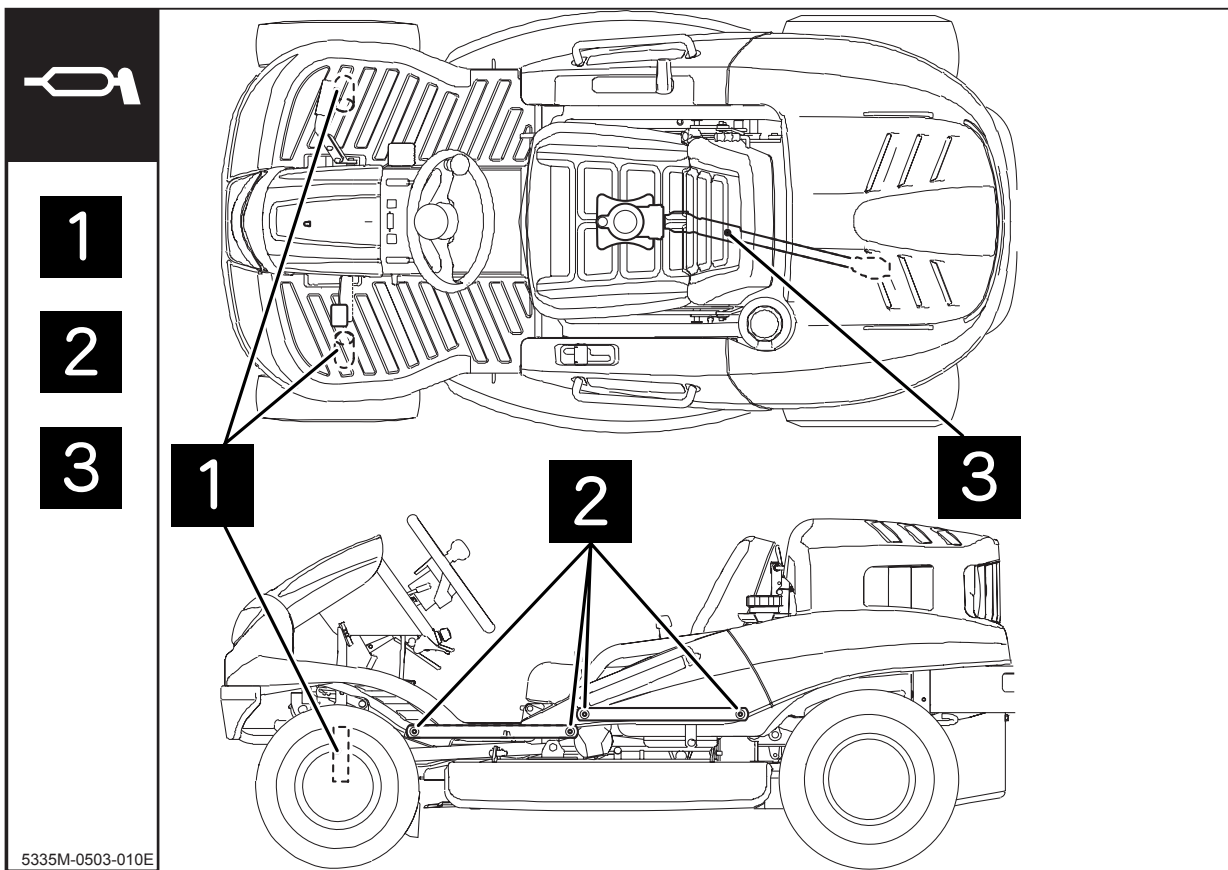



## List of Consumables and Spares

### ⚠ CAUTION!

- When replacing consumable or spare, always use CANYCOM genuine parts. Using non-CANYCOM parts may reduce machine's performance or service life. Note that it may also void warranty and certification for relevant standards.

| Item                           | Part No.     | Schedule   | Qty. |
|--------------------------------|--------------|--|------|
| <b>Engine</b>                  |              |  |      |
| Oil Filter Cartridge           | 248-65801-00 | Initially 50 hrs.<br>After - Every 200 hrs.<br>Replace if defective. | 1    |
| Air Cleaner Element            | 263-32610-A1 | Every 200 hrs or seasonally.   | 1    |
| Spark Plug (NGK BPR5ES)        | 065-01402-80 | Clean: every 50 hrs.<br>Replace if defective.                        | 2    |
| Wire (Throttle)                | 53320101100  | Replace if defective.  | 1    |
| <b>Fuel System</b>             |              |  |      |
| Hose (Carburator - Fuel Pump)  | 263-68006-B3 | Every 2 years.   | 1    |
| Hose (Fuel Pump - Fuel Filter) | 263-68007-B3 | Every 2 years.   | 1    |
| Hose (Fuel Filter - Fuel Cock) | 53320316000  | Every 2 years.   | 1    |
| Hose(Fuel Cock - Fuel Tank)    | 53320315000  | Every 2 years.   | 1    |
| <b>Drive Train</b>             |              |  |      |
| V-belt (HST)                   | 08521300036  | Replace if defective.  | 1    |
| Tire (Front)*1, *2             | 53322202000  | Replace if defective<br>or reaches the wear limit.                   | 2    |
| Tire (Front)*3                 | 53042204000  | Replace if defective<br>or reaches the wear limit.                   | 2    |
| Tire (Rear)*1, *2              | 53322302000  | Replace if defective<br>or reaches the wear limit.                   | 2    |
| Tire (Rear)*3                  | 53042301100  | Replace if defective<br>or reaches the wear limit.                   | 2    |
| Tire Tube (Front)*1, *2        | 53042205000  | Replace if defective.  | 2    |
| Tire Tube (Front)*3            | 53042205000  | Replace if defective.  | 2    |
| Tire Tube (Rear)*1, *2         | 53322303000  | Replace if defective.  | 2    |
| Tire Tube (Rear)*3             | 42012543000  | Replace if defective.  | 2    |
| Brake Lining (Rear)            | 73019901000  | Replace if defective.<br>(Replace in pairs)                          | 2    |
| Brake Lining (Front)           | 73069901000  | Replace if defective.<br>(Replace in pairs)                          | 2    |
| Wire (Rear Brake)              | 53323305000  | Replace if defective.  | 1    |
| Wire (Front Brake)             | 53323306000  | Replace if defective.  | 1    |

\*1: CMX227, \*2: CM 226, \*3: CMX186, CM185

| Item  | Part No.    | Schedule              | Qty. |
|---|-------------|-----------------------|------|
| <b>Drive Train</b>                            |             |                       |      |
| Wire (Differential Lock)                      | 53323402000 | Replace if defective. | 1    |
| Wire (AWD)*1                                  | 53323452000 | Replace if defective. | 1    |
| Cooling Fan                                   | 53352023000 | Replace if defective. | 1    |
| <b>Cutting System</b>                         |             |                       |      |
| Blade Set (Iai)                               | Z3324202010 | Replace if defective. | 1    |
| Rubber Plate (Front Skirt, Center)*1          | 53322114000 | Replace if defective. | 1    |
| Rubber Plate (Front Skirt, Center)*2          | 53332109000 | Replace if defective. | 1    |
| Rubber Plate (Front Skirt, Center)*3          | 53382114000 | Replace if defective. | 1    |
| Rubber Plate (Front Skirt, Center)*4          | 53342109000 | Replace if defective. | 1    |
| Rubber Plate (Front Skirt, Sides)*1           | 53322113000 | Replace if defective. | 2    |
| Rubber Plate (Front Skirt, Sides)*2           | 53332108000 | Replace if defective. | 2    |
| Rubber Plate (Front Skirt, Sides)*3           | 53382113000 | Replace if defective. | 2    |
| Rubber Plate (Front Skirt, Sides)*4           | 53342108000 | Replace if defective. | 2    |
| Rubber Plate (Front Diff.-Blade Shield)*1, *3 | 53352111000 | Replace if defective. | 1    |
| Rubber Plate (Front Diff.-Blade Shield)*2, *4 | 53362114000 | Replace if defective. | 1    |
| Rubber Plate (Front Axle, Rear Right)*1       | 53212118000 | Replace if defective. | 1    |
| Rubber Plate (Front Axle, Rear Right)*2, *4   | 53332112000 | Replace if defective. | 1    |
| Rubber Plate (Front Wheel, Inside)*1, *3      | 53322116000 | Replace if defective. | 1    |
| Rubber Plate (Front Wheel, Inside)*2, *4      | 53062121000 | Replace if defective. | 1    |
| Rubber Plate (Front Wheel, Rear Inside)*2, *4 | 53232132000 | Replace if defective. | 1    |
| Rubber Plate (Blade Shield, Rear)             | 53324113000 | Replace if defective. | 1    |
| Rubber Plate (Blade Shield, Rear Left)        | 53324114000 | Replace if defective. | 1    |
| V-Belt (Cutting Rotary)                       | 08521600037 | Replace if defective. | 2    |
| Brake Lining (Cutting Rotary)                 | 53104301000 | Replace if defective. | 2    |
| Wire (Cutting Rotary Clutch)                  | 53322408000 | Replace if defective. | 1    |
| Free Lock (Cutting Height Adjuster)           | 53324068000 | Replace if defective. | 1    |
| Cutting Blade Stay                            | 53324201000 | Replace if defective. | 1    |

\*1: CMX227, \*2: CM 226, \*3: CMX186, \*4: CM185

| Item                     | Part No.    | Schedule              | Qty. |
|--------------------------|-------------|-----------------------|------|
| <b>Electrical System</b> |             |                       |      |
| Battery                  | 37053901000 | Replace if defective. | 1    |
| Fuse, 30A (Green, Main)  | 09801003002 | Replace if defective. | 1    |
| Fuse 10A (Red, Lights)   | 09801001002 | Replace if defective. | 1    |
| Light Bulb (Head Lamp)   | 53320203100 | Replace if defective. | 1    |
| Light Bulb (Tail Lamp)*1 | 09808121502 | Replace if defective. | 1    |

## Removing and Installing Body Panels

### ⚠ CAUTION!

- Cut or pinch hazard exists when removing or installing body panels; beware of sharp edges and pinch points.
- Make certain to reinstall panels after removing for repairs or inspection.

### Front Cover

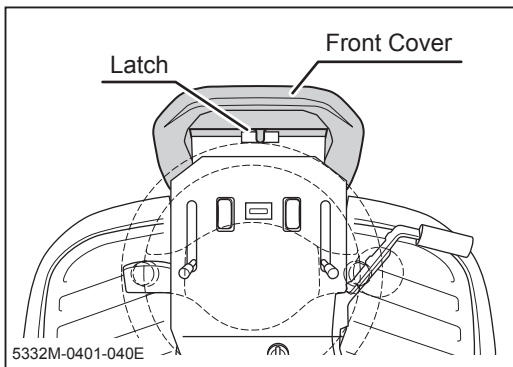

1. Pull top side of front cover to unlock latch.

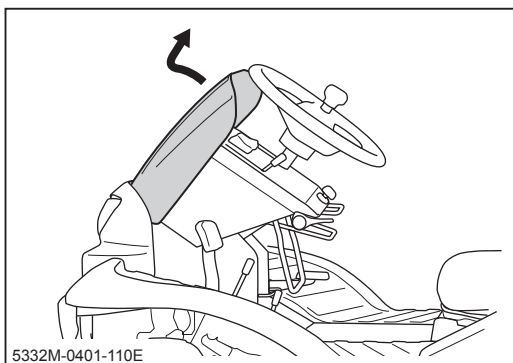

2. Pull up front cover.

#### NOTE

- Tool box is provided under the front cover. Use this tool box to store tools or substitute cutting blades.

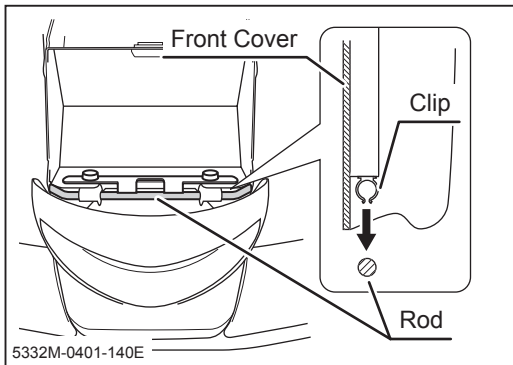

3. Raise steering wheel to the maximum angle and fit clip on the back of front cover to rods.
4. Fit upper part of front cover.

## NOTE

- Beware not to catch front cover by the plates on both sides when you installing front cover.

## Head Lamp

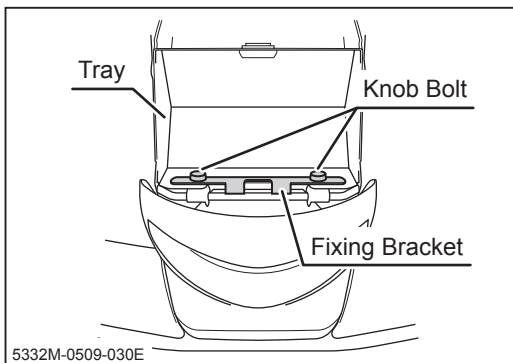

1. Remove front cover.
2. Remove 2 knob bolts fixing the tray.
3. Remove fixing bracket and lift tray.

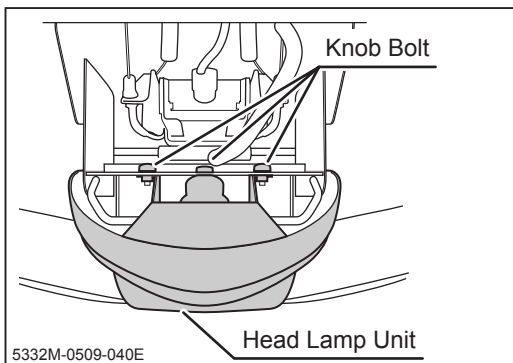

4. Remove 3 knob bolts fixing head lamp unit to remove head lamp unit.

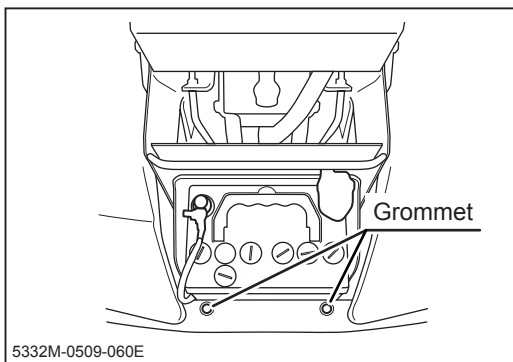

5. Insert projections at the bottom of head lamp unit into holes of grommet on bumper and install adversely.

## Engine Hood

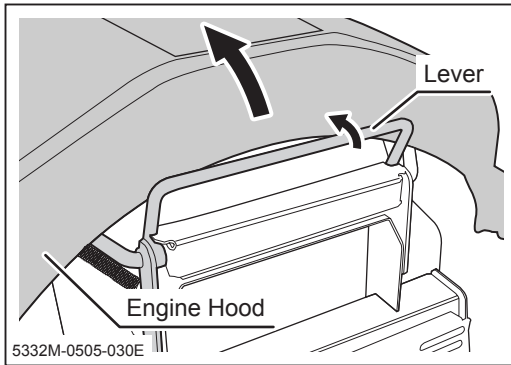

1. Pull lever and open engine hood.

## Lower Rear Cover

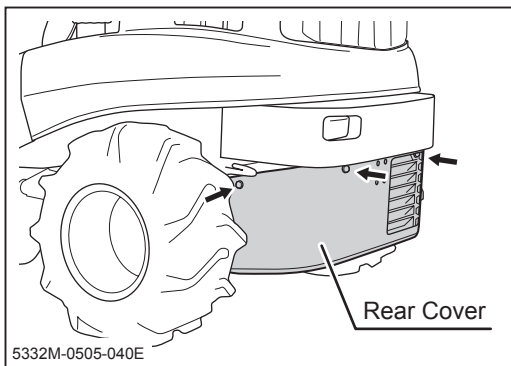

1. Remove 4 bolts.
2. Remove lower rear cover.

## Step

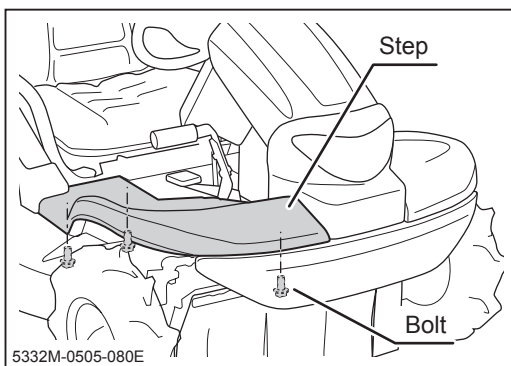

1. Remove 3 bolts fixing step.
2. Remove step.
3. Remove step on the other side in the same way.

## Seat Bracket

### ⚠ CAUTION!

- Always slide seat to the rear-most position when lifting seat. If seat is not in the rear-most position, slide lever may interfere with step, preventing seat to be lifted to the holding position.

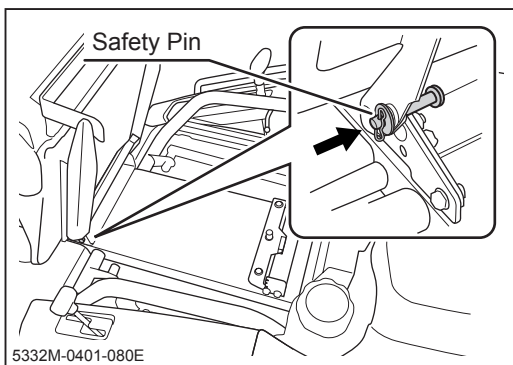

1. Slide seat to the rear-most position.
2. Lift seat and push safety pin toward inside to hold seat.

### NOTE

- Move seat and check if the seat is held in place firmly.

## Cutting Blade Shield

### ⚠ DANGER!

- Stop engine before opening cutting blade shield. Opening shield when cutting blade is moving may result in injury or death.

### ⚠ WARNING!

- Make sure cutting blade shield is securely locked in the lowest position and does not open to the side. Loose shield may allow objects to be thrown, resulting in injury to the operator or by-standers or in property damage.

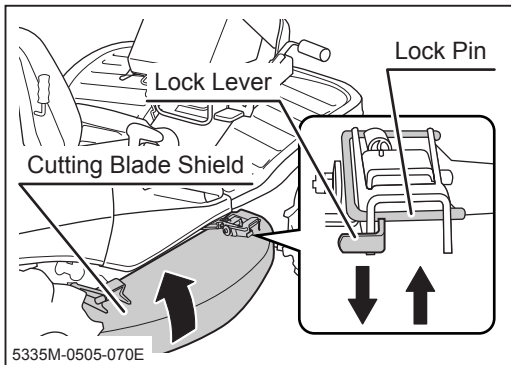

### Flipping up shield

1. Push lock pin to unlock shield.
2. Pull up lock lever and move shield up or down to one of three positions.
3. Press down lock lever to lock shield. Lock pin will also return to lock position automatically.

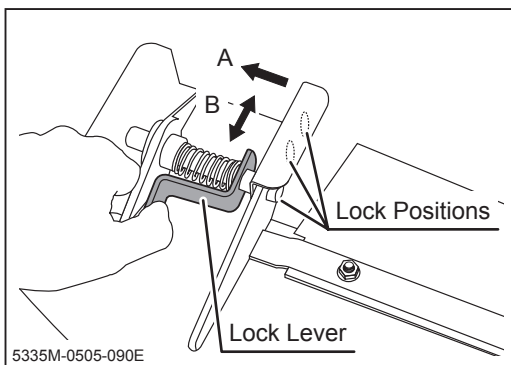

### Opening shield to the side

1. Squeeze lock lever as shown (A).
2. Keep lock lever squeezed and move shield to one of three lock positions (B).
3. Release lock lever at the selected lock position so that the pin on lock lever positively fits into the hole at lock position.

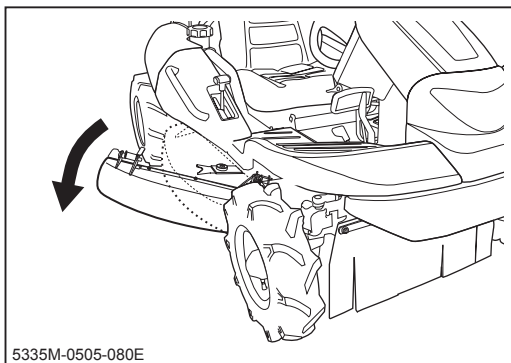

## Engine

### **⚠ WARNING!**

- Always stop engine and remove ignition key before servicing.
- An engine that has been running is very hot. Allow engine to cool before servicing, or severe burns may result.
- Keep fire and spark away when servicing.

## Engine Oil

### **⚠ CAUTION!**

- Make certain to fill engine with correct grade of oil to the specified level. Insufficient amount or wrong grade of oil reduces performance and may cause permanent damage to engine.
- Dispose of the drained oil properly.

### NOTE

- To obtain correct reading, check oil level before starting, or wait about 10 minutes after stopping engine to allow oil to drain back to oil pan.
- Always check oil level on a level surface.
- Oil to use and capacity: Page 45.

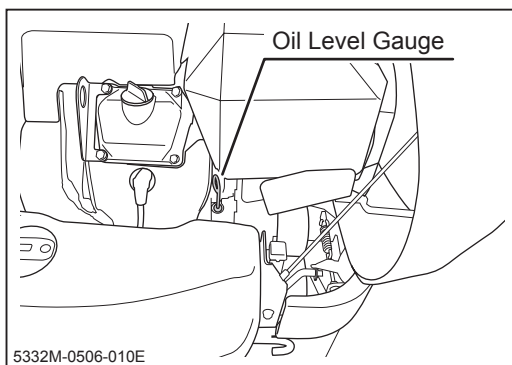

### Inspecting

1. Park machine on a level surface.
2. Open engine hood.
3. Pull out dipstick and wipe it clean.
4. Insert dipstick fully and pull it out.



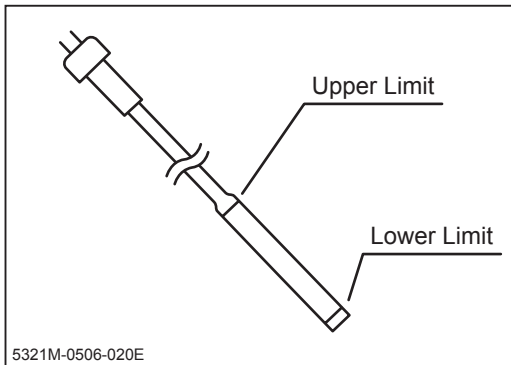

5. Visually inspect oil level. Make sure oil level is between upper and lower limits. If it is below lower limit, add oil.
6. Visually inspect condition of oil. If it is too dirty or viscosity is not normal, change oil.
7. Put dipstick back in place.
8. Close engine hood.

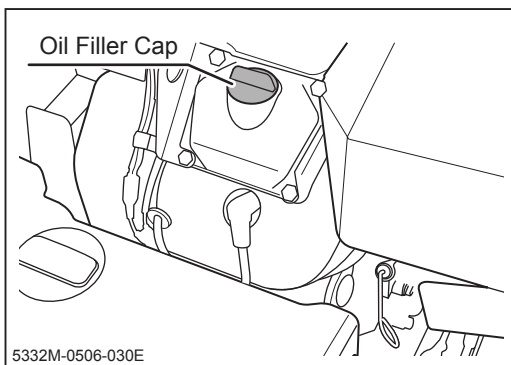

### Filling

1. Open engine hood.
2. Remove oil filler cap.
3. Fill specified amount of correct oil into filler.
4. Check oil level. Make sure oil level is between upper and lower limits.
5. Put oil filler cap back in place.
6. Close engine hood.

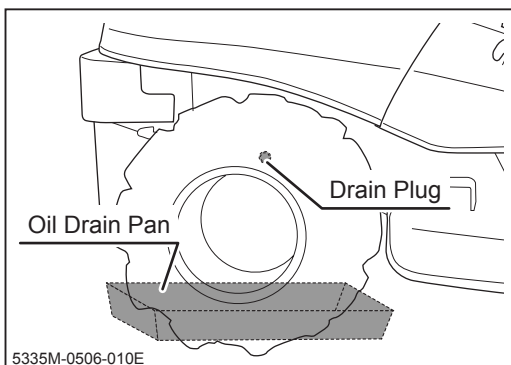

### Changing

1. Have an appropriate oil drain pan.
2. Open engine hood.
3. Remove oil filler cap.
4. Remove drain plug to drain oil.
5. Put drain plug back in place.
6. Fill oil.
7. Check oil level and to make sure oil level is appropriate.
8. Put oil filler cap back in place.
9. Close engine hood.

## Oil Filter Cartridge

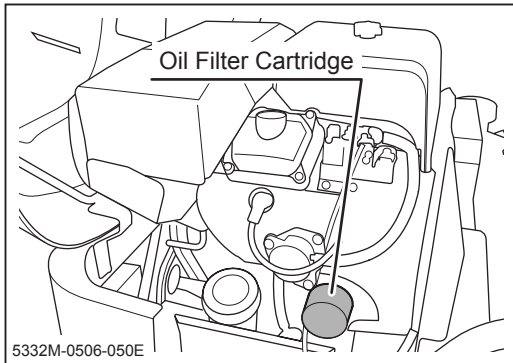

1. Open engine hood.
2. Follow the instructions in **Operator's Manual for the engine** to change oil filter cartridge.
3. Close engine hood.

## Air Cleaner

### **⚠ CAUTION!**

- Clean air cleaner element daily. Dirty air cleaner element causes poor starting, reduces engine performance and shortens engine life.
- Replace air cleaner element if damaged.

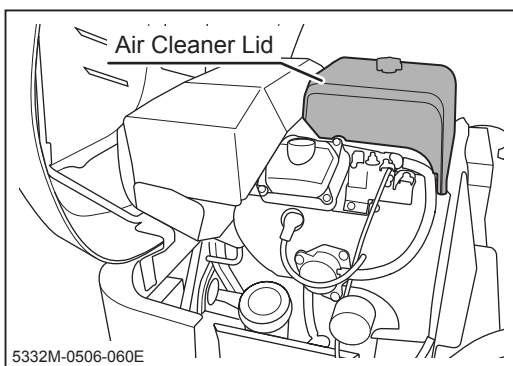

1. Open engine hood.
2. Follow the instructions in **Operator's Manual for the engine** to inspect, clean or change air cleaner element.
3. Close engine hood.

## Spark Plugs

### ⚠ CAUTION!

- Never pull ignition cable when removing a spark plug cap. Conductor in the cable may be severed or damaged.
- If a spark plug is damaged, replace it with a new one.

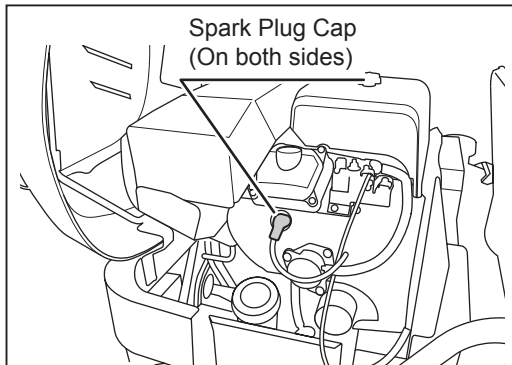

1. Open engine hood.
2. Follow the instructions in **Operator's Manual for the engine** to inspect, clean, or change spark plugs.
3. Close engine hood.

## Drive Train

### ⚠ WARNING!

- Stop engine and remove ignition key when servicing drive train.
- Allow machine to cool off before servicing. Engine and its ancillaries are very hot after operation and may pose a burn hazard.

### ⚠ CAUTION!

- Dispose of drained oil properly.

## Tires

### ⚠ CAUTION!

- Inflate tires to the specified pressure. Under- or over-inflation causes uneven wear or other damages to tires.

|                       | Tire Size        | Pressure KPa(kgf/cm <sup>2</sup> ) |
|-----------------------|------------------|------------------------------------|
| <b>CMX227 / CM226</b> |                  |                                    |
| Front Wheel           | AGR 4.00-7 (2PR) | 120 (1.2)                          |
| Rear Wheel            | 17×8.00-8 (4PR)  | 240 (2.4)                          |
| <b>CMX186 / CM185</b> |                  |                                    |
| Front Wheel           | AGR 3.50-7 (2PR) | 110 (1.1)                          |
| Rear Wheel            | 16×7.00-8 (2PR)  | 110 (1.1)                          |

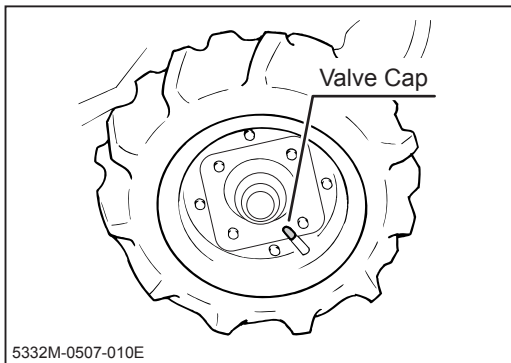

1. Park machine on a level ground.
2. Remove valve cap.
3. Check tire air pressure. If different from the specified values, adjust pressure.
4. Put valve cap back in place.

## Transmission Oil

### NOTE

- Oil to use and capacity: Page 45.

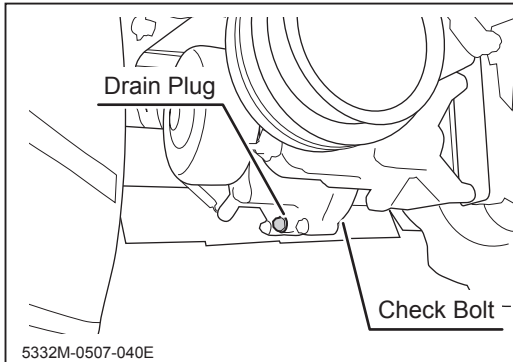

1. Park machine on a level ground.
2. Have an appropriate oil drain pan.
3. Remove transmission oil drain plug to drain oil.
4. Install drain plug back in place.

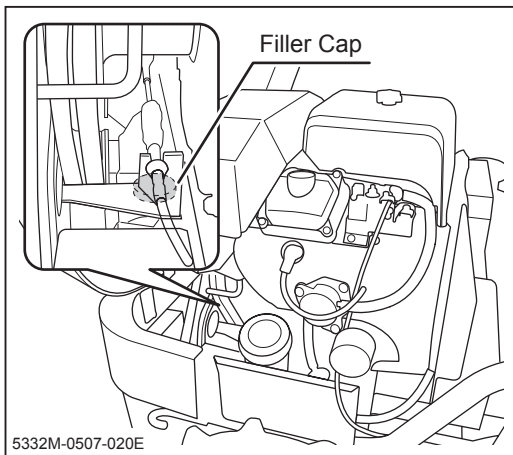

5. Open engine hood.
6. Remove transmission oil filler cap.
7. Remove check bolt.
8. Fill specified amount of correct oil into filler, up to check bolt hole.
9. Put check bolt back in place.
10. Put filler plug back in place.
11. Close engine hood.

## Front Axle Oil (CMX227 / CMX186)

### NOTE

- Oil to use and capacity: Page 45.

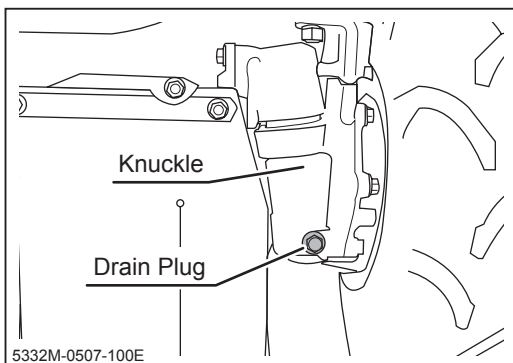

1. Park machine on a level ground.
2. Have an appropriate oil drain pan.
3. Remove drain plug on the left front knuckle to drain oil.
4. Remove drain plug on the right front knuckle to drain oil as well.

## NOTE

- Drain plug for the right front knuckle is on the back side of the front axle.

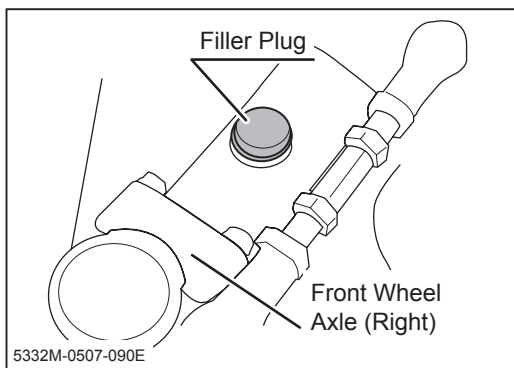

5. Install both drain plugs back in place.
6. Remove right front step.
7. Remove oil filler cap.
8. Fill specified amount of oil into filler.
9. Install filler plug back in place.
10. Install right front step.

## HST (Hydrostatic Transmission) Fluid

### NOTE

- To obtain correct reading, check HST fluid level before starting, or wait until HST fluid cools off sufficiently. Hot HST fluid expands in volume and does not provide correct reading.
- When oil is sufficiently cooled and is at the [MIN] level, its amount is sufficient.
- Do not exceed beyond [MAX] level. HST fluid may expand and overflow.
- Oil to use and capacity: Page 45.

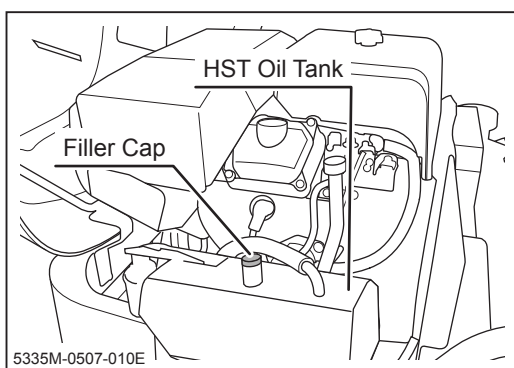

### Inspecting - Models with charge-pump

1. Park machine on the level ground.
2. Open engine hood.
3. Unscrew and remove filler cap.

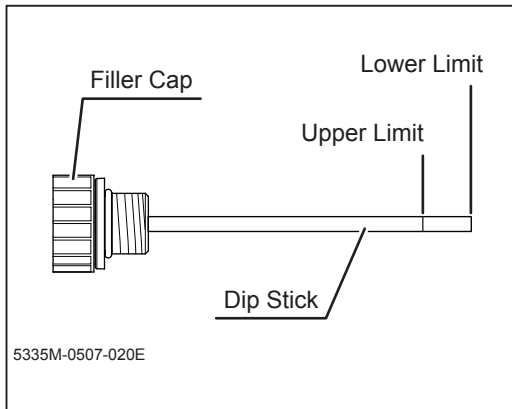

4. Wipe dip stick with clean cloth. Reinstall filler cap and screw it fully.
5. Unscrew and remove filler cap again. Visually inspect that oil level is between the upper and lower limits on dip stick. If it is below the lower limit, fill oil.
6. Reinstall filler cap and screw it fully.
7. Close engine hood.

#### Filling - Models with charge-pump

1. Open engine hood.
2. Remove filler cap.
3. Fill specified HST fluid into filler so that oil level is between upper and lower limits on dipstick.
4. Reinstall filler cap back in place and screw it securely.
5. Close engine hood.

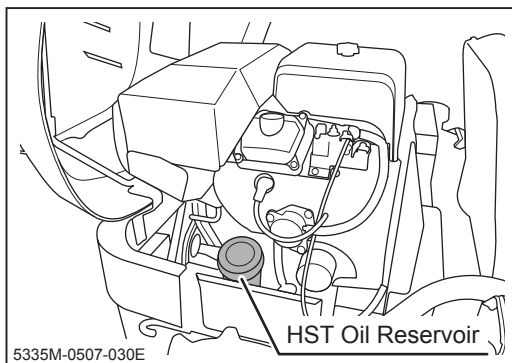

#### Inspecting - Models without charge-pump

1. Park machine on the level ground.
2. Open engine hood.
3. Visually inspect that oil level is between [MIN] and [MAX] lines on oil reservoir. If it is below [MIN], fill oil.
4. Close engine hood.

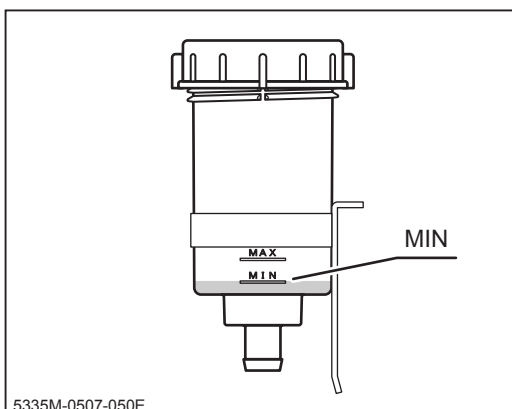

#### Filling - Models without charge-pump

1. Open engine hood.
2. Remove cap on HST oil reservoir.
3. Fill specified HST fluid into reservoir so that oil level is above [MIN] line on reservoir.
4. Reinstall cap back in place and screw it securely.
5. Close engine hood.

## Drive Belt

### ⚠ CAUTION!

- Adjust belt tension properly. Inproperly tensioned belt may reduce performance and its service life.

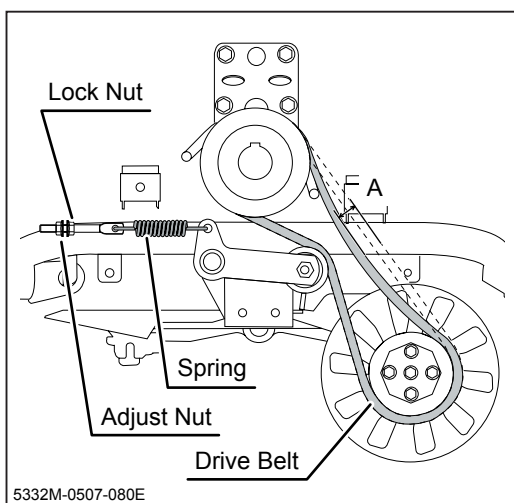

1. Open engine hood.
2. Check V-belt tension. Push V- belt by finger and check that deflection at center point A is in the range of 10 to 20 mm. If it is out of this range, adjust with adjust nut.
3. Visually inspect belt. Replace belt if it is damaged. For replacement, contact your CANYCOM representative.
4. Close engine hood.

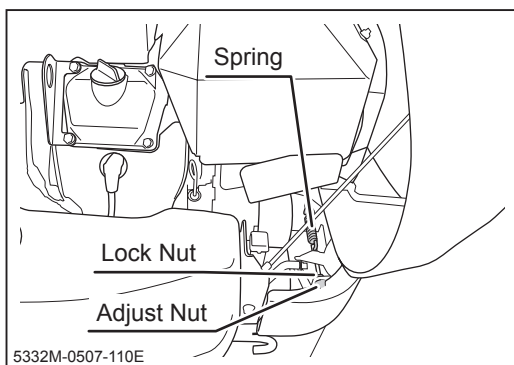



## Parking Brake

### **⚠ WARNING!**

- Always keep brake adjusted for maximum performance. Improperly adjusted brakes may result in property damage, serious injury, or death.

1. Park machine on level ground.
2. Remove left step.

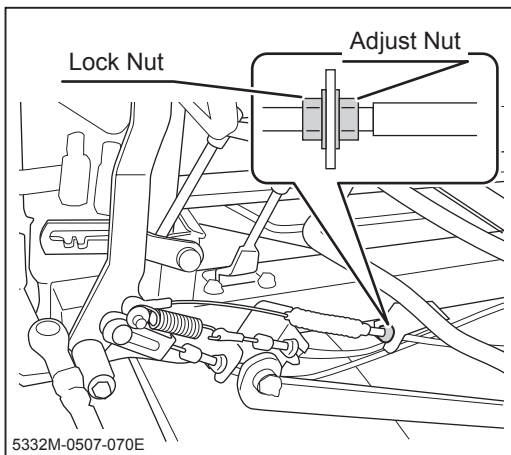

### Rear Brake

3. Loosen lock nut
4. Adjust with adjust nut when brake pedal is free so that the brake does not drag.
5. Adjust brake so that the brake works and the brake pedal locks securely when brake pedal is locked
6. Tighten lock nut.

### NOTE

- If brake does not work even the brake pedal is locked, the brake shoe is worn out. Please contact your CANYCOM representative for replacement.

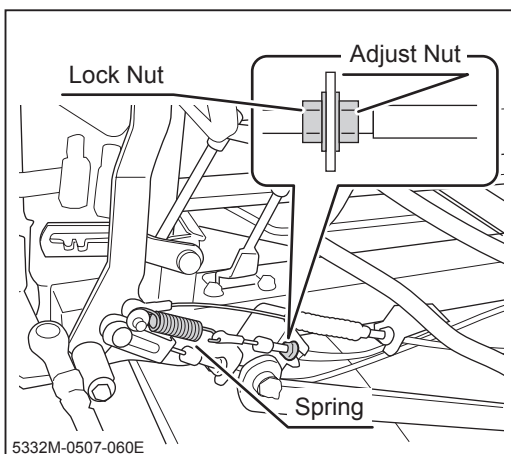

### Front Brake (CMX227/CMX186)

7. Lock brake pedal and inspect that the stretch of spring is between 5mm and 8mm. If it is not within this range, adjust it with adjust nut.
8. Tighten lock nut after adjustment
9. Install left step back in place.

## Cutting System

### **⚠ WARNING!**

- Stop engine and remove ignition key when servicing.
- Allow machine to cool off before servicing. Engine and its ancillaries are very hot after operation and may pose a burn hazard.

## Cutting Blades

### **⚠ WARNING!**

- When a blade is damaged, replace it and the other blade immediately. Always replace blades in pair. Damage due to vibration may occur.
- When replacing blades, always replace both blades. Replace blade pins and wave washers also.
- When a foreign object is tangled with the blade, immediately stop the engine and remove the foreign object. Damage due to vibration may occur.
- When replacing blades, inspect blade stay. If stay is worn beyond wear limit, damaged or deformed, replace it immediately. Contact your CANYCOM representative.

### **⚠ CAUTION!**

- Blades and blade stay can become sharp due to wear. When handling blade or blade stay, always wear thick gloves and handle carefully. Injury may occur.
- When replacing a blade, do not force it to remove. Blade can move suddenly, causing injury. When it is difficult to remove, clean blade and remove foreign object. Turn blade back and forth to remove.

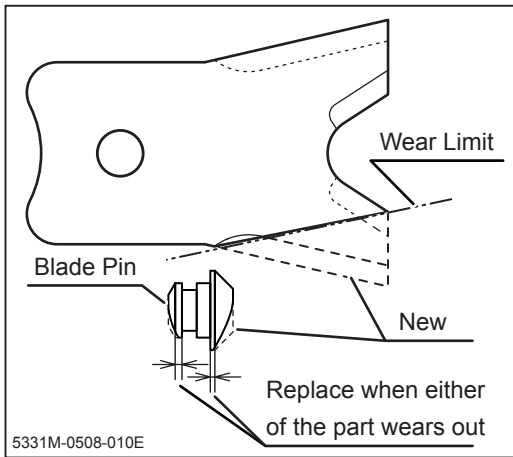

**Inspecting**

1. Open cutting blade shield.
2. Visually inspect blades and pin for wear and damage. If blades are worn normally, turn them over and use. Replace if both edges are worn. If blades or pin are worn excessively, deformed, damaged, or missing, replace them with new components.

**NOTE**

• **Wear Limit**

**Blade:** Up to line connecting outer edge and inner edge.

**Blade Pin:** Up to either of the shoulder.

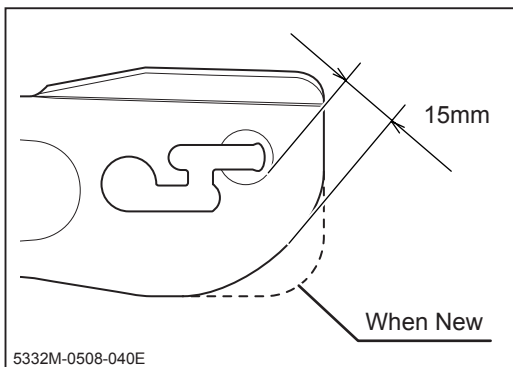

3. Inspect cutting rotor stay. If stay is worn excessively, deformed or damaged, replace with a new component.
4. Close blade shield.

**NOTE**

• **Wear Limit:** Up to the solid line in the left figure (should have more than 15mm clearance between edge of rotor stay and mounting slot.)

• **Contact your CANYCOM representative for replacement of rotor stay.**

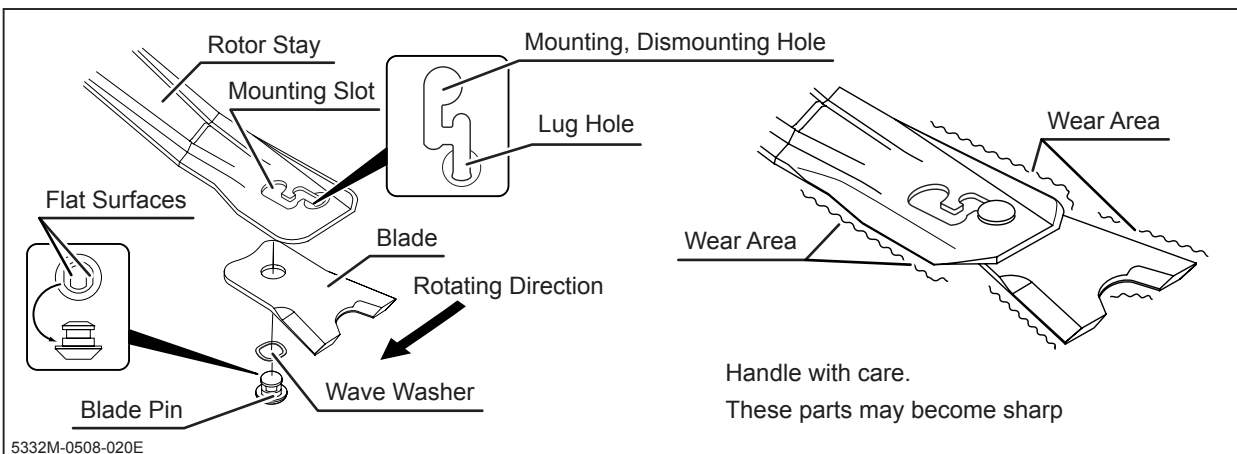

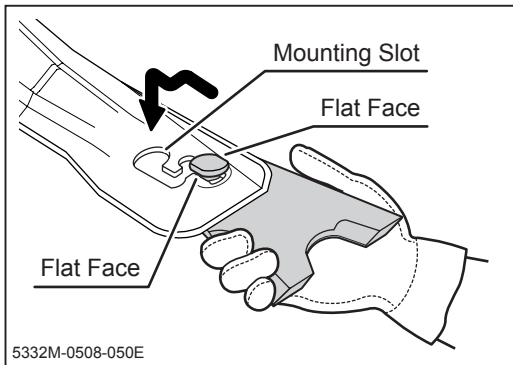

## Replacing

1. Open cutting blade shield.
2. Noting the direction of the flat faces on mounting pin, shift blade along mounting slot to remove blade.

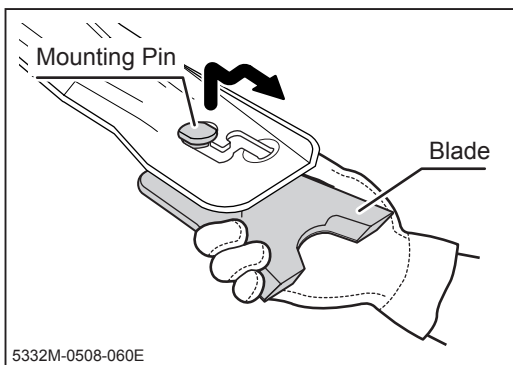

3. Install new mounting pin and wave washer to blade and shift blade along mounting slot, noting the direction of the flat faces.

## NOTE

- Always put thick gloves on and be cautious when handling blade because both edges of rotor stay can get sharp by wear.
- Wear Limit: See page 66
- If dirt or grass enters into mounting slot, making removal of blade difficult, remove dirt or grass with a screw driver before removing blade.
- If it is difficult to remove blade, use 24mm spanner to remove

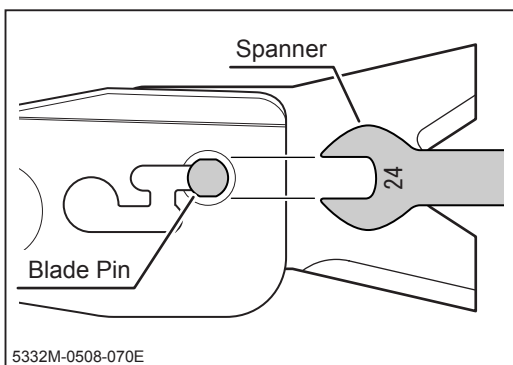

## Cutting Rotary Drive Belt

### ⚠ CAUTION!

- Adjust belt tension properly. Inproperly tensioned belt may reduce performance and its service life.
- Always adjust cutting rotary brake after adjusting cutting rotary drive belt.

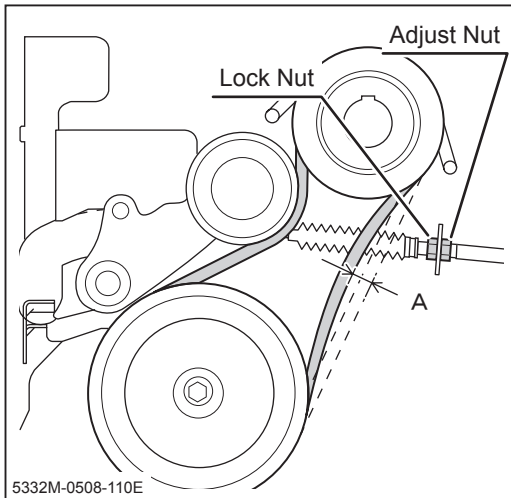

### Inspecting

1. Open engine hood.
2. Move cutting rotor clutch lever to [ON].
3. Check V-belt tension. Push V- belt by finger and check that deflection at center point A is in the range of 10 to 15 mm. If it is out of this range, adjust with adjust nut.
4. Visually inspect belt. Replace belt if it is damaged. For replacement, contact your CANYCOM representative.
5. Move cutting rotor clutch lever to [OFF].
6. Close engine hood.

### Adjusting

1. Open engine hood.
2. Move cutting rotor clutch lever to [ON].
3. Loosen lock nut.
4. Adjust V-belt with adjust nut so that the deflection at center point A is in the range of 10 to 15 mm when the belt is pressed by finger.
5. Tighten lock nut.
6. Move cutting rotor clutch lever to [OFF].
7. Close engine hood.

## Cutting Rotary Brake

### **⚠ DANGER!**

- Never place any part of body under cutting blade shield when cutting blade is rotating.

### **⚠ WARNING!**

- Do not allow bystanders to come near machine when inspecting cutting rotary brake.
- Ride on machine when inspecting.
- Never attempt to check the performance of cutting rotary brake with cutting blade shield open. Stones or rocks can be thrown and cause damage to surrounding properties or persons.
- Inspect cutting rotary brake whenever the performance of it seems inadequate.
- Always adjust cutting rotary brake after adjusting cutting rotary drive belt.

### Inspecting

1. Start engine.
2. Turn throttle lever to [  (fast)] to raise engine speed.
3. Move cutting height adjust lever to [150] for CMX227 and CM226, or to [130] for CMX186 and CM185.
4. Move cutting rotary clutch lever to [ON] to rotate cutting blade.
5. Move cutting rotary clutch lever to [OFF] to observe if cutting blade stops. If it does not stop (if it keeps turning by inertia), adjust cutting rotary brake. To see if cutting rotary is running or not, observe the rotating sound of cutting blade, or open engine hood to observe the rotation of cutting blade V-belt. Avoid observing cutting blade directly.

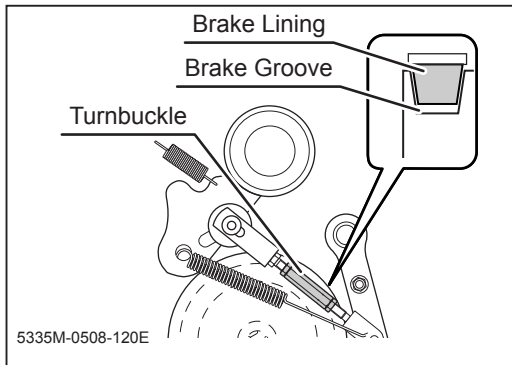

### Adjusting

1. Remove lower rear cover.
2. Adjust brake lining with turnbuckle so that the lining contacts firmly with brake groove when cutting rotary clutch lever is [ON], and there is a gap between the lining and the groove when cutting rotary clutch lever is [OFF].
3. Install lower rear cover back in place.
4. Inspect again. If cutting rotary does not stop, please contact your CANYVOM representative.

## Electrical System

### ⚠ WARNING!

- Always stop engine and remove ignition key when servicing electrical system.
- Shock hazard. Do not handle electrical components with wet hands.

## Battery

### ⚠ WARNING!

- Never charge battery when the fluid level is below "lower level" line. Charging battery with insufficient fluid may shorten battery life or cause an explosion.
- Battery fluid (diluted sulfuric acid) is corrosive and causes severe burns. Be extremely cautious when handling battery fluid. If battery fluid is spilled on clothes, immediately rinse with plenty of water. If spilled on skin or in an eye, immediately rinse with plenty of water and promptly consult a physician.
- Explosion hazard. Keep open flame or spark away from battery. Hydrogen gas generated during charging is extremely explosive.

## **⚠ WARNING!**

- **Never fill battery fluid beyond "upper level" line. Battery fluid may spill and cause damage to machine or injury to person.**
- **Always disconnect (-) terminal first, and connect (+) terminal first. Disconnecting or connecting in the opposite order may cause a short circuit.**
- **When installing battery, make certain to connect (+) and (-) terminals to their original positions. Avoid contact between terminals and other surrounding parts.**
- **Use wet cloth to clean battery. Dry cloth may generate static electricity, which may cause explosion.**
- **Do not touch terminals. Electric shock may occur.**

## **⚠ CAUTION!**

- **Always remove battery from machine before charging. Failure to do so causes damage to electrical components and wiring.**
- **Follow battery charger user's manual when charging.**

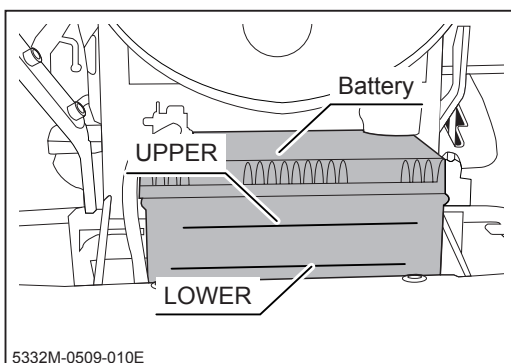

### **Inspecting**

1. Park machine on level ground.
2. Remove front cover.
3. Visually inspect that battery fluid level is between "UPPER" level and "LOWER" level lines.
4. If fluid level is near or below "LOWER" level line, fill.
5. Install front cover back in place.

### **NOTE**

- **Instruction of removing head lamp and battery is indicated back of the front cover.**



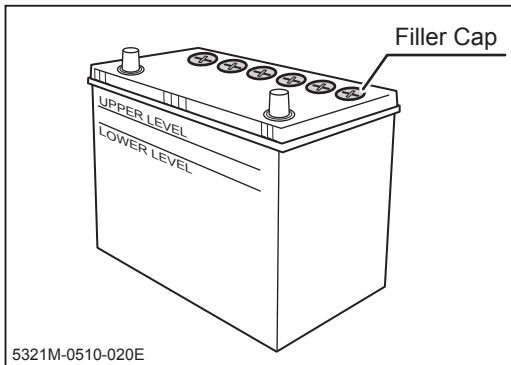

5321M-0510-020E

**Filling**

1. Remove front cover.
2. Remove battery.
3. Remove filler cap.
4. Fill distilled water to "UPPER LEVEL" line.
5. Install filler cap.
6. Install battery.
7. Install front cover.

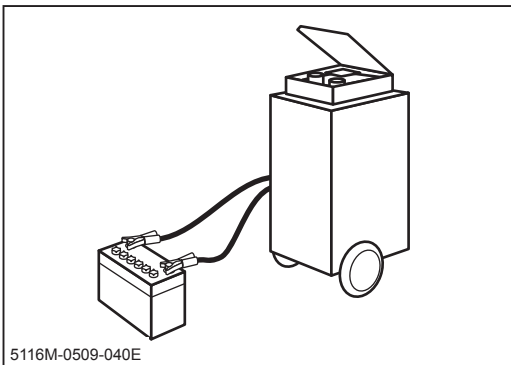

5116M-0509-040E

**Charging**

1. Remove front cover.
2. Remove battery from machine.
3. Follow instructions in battery charger user's manual to charge battery.
4. When battery is fully charged, install battery back in place.
5. Install front cover back in place.

**Fuses****⚠ CAUTION!**

- If a fuse blows, investigate the cause before replacing.
- Always replace a fuse with one of the correct rating.

**NOTE**

- Main Fuse: 30A. Lights Fuse: 10A
- Replacement Fuse: Page 49.

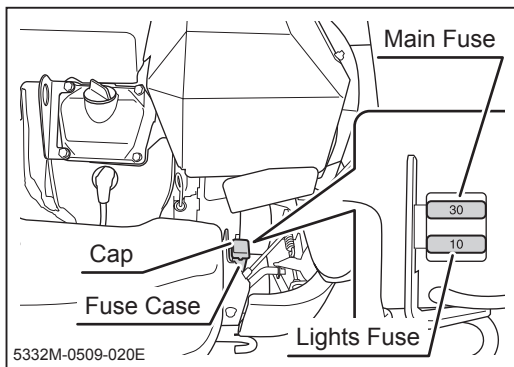

1. Open engine hood.
2. Open fuse case cap. Remove fuse and visually inspect. If it is blown, replace it with new one of the same rating.
3. Install fuse.
4. Install fuse case cap.
5. Close engine hood.

## Light Bulbs

### ⚠ CAUTION!

- When light bulb is burnt out, replace it with a new bulb.
- When replacing, always use a bulb of the correct rating. Wrong bulb may cause malfunction or damage in electrical system.
- Do not touch bulb when it is hot. It may cause burns.
- Do not touch the glass part of light bulb directly with fingers. It may reduce service life.

### NOTE

- Light Bulbs to use: Page 48.

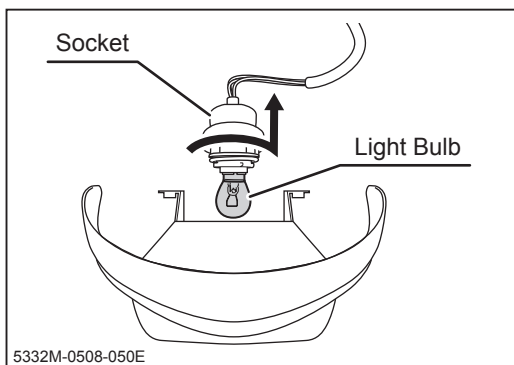

### Head Lamp

1. Remove front cover and head lamp unit.
2. Turn socket to remove.
3. Replace with new light bulb.
4. Install socket.
5. Install head lamp and front cover.

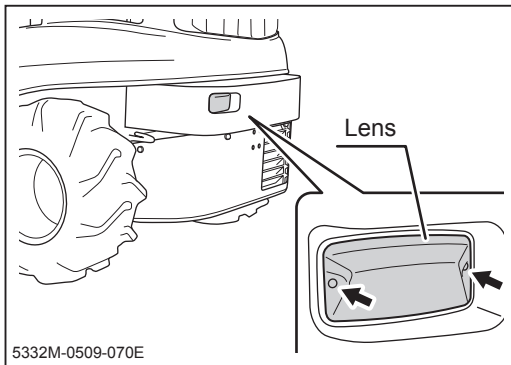

## Rear Lamp (CMX227)

1. Remove 2 screws and remove lens.

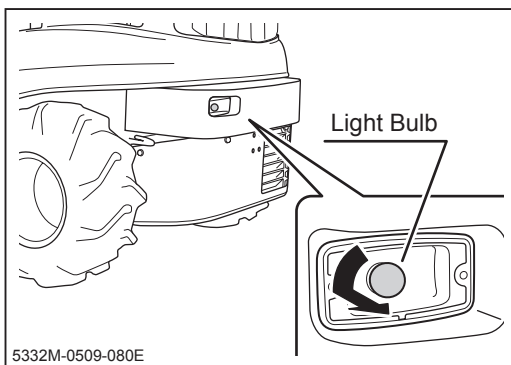

2. Replace with a new light bulb.
3. Install lens back in place.

## After Use Care

### Cutting System

#### **⚠ DANGER!**

- Never place any part of body under cutting blade shield when cutting blade is rotating.

#### **⚠ WARNING!**

- Do not allow bystanders to come near machine when cutting blade is rotating.
- Always stay on machine when performing this operation
- Never attempt to clean cutting system with cutting blade shield open. Stones or rocks can be thrown and cause damage to surrounding properties or persons.
- Turn cutting rotary clutch to [ON] only when cleaning. Keep it in [OFF] position all the other times.

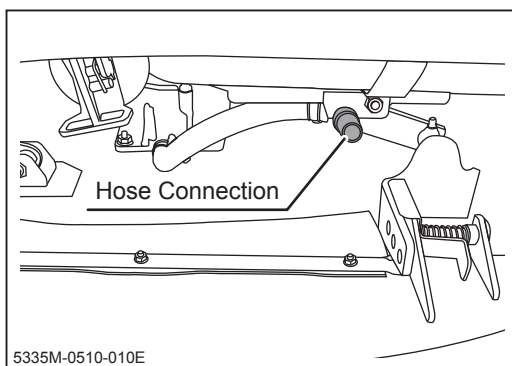

1. Park machine.
2. Set cutting height to about 50mm.
3. Connect hose to hose connection. Run water through hose.
4. Start engine.
5. Turn throttle lever to [🐾 (fast)] to raise engine speed.
6. Move cutting rotary clutch lever to [ON] to rotate cutting blade to clean.
7. When cleaning is done, move cutting rotary clutch lever to [OFF] to stop cutting blade.
8. Move cutting height adjust lever to [150] for CMX227 and CM226, [130] for CMX186 and CM 185.

9. Turn throttle lever to [ (slow)] to lower engine speed.
10. Stop machine and remove hose.

**NOTE** 

---

- Do not set cutting height too low. It may hit ground.

**After Normal Use**** WARNING!**

- Fire hazard; clean machine of cut grass and similar material after use. Cut grass that is accumulated on the machine can catch fire.
- Clean cooling air intake in front of the engine. If cooling air intake is clogged or blocked, it causes overheating, resulting in damages to the machine.

** CAUTION!**

- Do not wash engine or control panel with running water; water may enter inside and cause rust or damage.
- Always clean cutting blades and blade pins after use. Dirt or foreign matters may solidify or corrode blades and make it difficult to remove them.

1. Clean machine; wash off dirt, mud, and remove grass and other foreign materials after use.
2. Clean cutting system. (See page 75)
3. Check if cutting blades can be rotate after removing foreign objects such as mud.
4. If machine is to be left outside, cover machine with protective, water-proof covering after it is cooled off.

## After Cold Weather Use

### **⚠ WARNING!**

- Fire hazard; clean machine of cut grass and similar material after use. Cut grass that is accumulated on the machine can catch fire.

### **⚠ CAUTION!**

- Do not wash engine or control panel with running water; water may enter inside and cause rust or damage.
- Clean machine after use; dirt or foreign objects may freeze and cause damage.
- Do not attempt to move machine when it becomes inoperable due to freezing

1. Clean machine; wash off dirt, mud, and remove grass and other foreign materials after use.
2. Park machine on a paved or firm, dry surface, or on a bed of lumber.
3. If machine is to be left outside, cover machine with protective, water-proof covering after it is cooled off.

## Storage

### **⚠ WARNING!**

- Fire hazard; do not store machine where there is a possibility of ignition.

### **⚠ CAUTION!**

- Do not wash engine or control panel with running water; water may enter inside and cause rust or damage.
- Clean machine before storage; dirt or foreign objects may freeze and cause damage.
- Do not store machine in a humid, dusty, or hot place.

1. Park machine.
2. Clean machine; wash off dirt, mud, and remove grass and other foreign materials after use.
3. Check machine according to **Maintenance Schedule** (Page 41). If a problem is found, repair.
4. Wipe clean steel parts with oiled cloth and grease specified grease points.
5. Change engine oil.
6. Clean air cleaner element.
7. Drain fuel from carburetor and fuel tank.
8. Inflate tires to a pressure slightly higher than the specified value. Chock front and back of front wheels.
9. Remove battery from machine. Inspect, fill, and charge battery.
10. Cover machine with protective, water-proof covering after machine is cooled off.

### **NOTE**

---

- Battery discharges even when it is not in use. A battery may hold charge for a few months, but it is a good practice to charge battery before it goes flat; it will extend battery life.
- Refer to Operation Manual for the engine, for detailed instructions on preparing engine for storage.

## Troubleshooting

- If any malfunction or abnormal condition is found, immediately stop using the machine and take an appropriate measure according to the Troubleshooting chart below. If the malfunction or abnormal condition is not listed in the chart, or the suggested measure does not solve the problem, consult with your CANYCOM representative.
- Some corrective measures listed below require special knowledge and/or equipment. Please contact your CANYCOM representative in such a case.

| Area                          | Malfunction                                     | Possible Cause                                 | Corrective Measure  | Ref.               |
|-------------------------------|---|--|---|--------------------|
| Engine                        | Engine does not start, or is difficult to start | Out of fuel.                                   | →Fill fuel.   | Page 17            |
|                               |   | Excessive fuel in the engine.                  | →Wait a while and try starting again.   |                    |
|                               |   | Battery capacity is insufficient.              | →Add battery fluid.<br>→Charge battery.<br>→Replace battery.  | Page 70<br>Page 70 |
|                               |   | Battery cable is disconnected.                 | →Connect the battery cable.   |                    |
|                               |   | Insufficient or wrong oil.                     | →Fill or change oil.  | Page 55            |
|                               |   | Dirty or damaged spark plug.                   | →Clean or replace the spark plug.   | Page 58            |
|                               |   | Other (other than the above).                  | →Follow the instructions in "Starting" to restart. If problem persists, please contact your CANYCOM representative. | Page 22            |
|                               | Engine stalls.                                  | Out of fuel.                                   | →Fill fuel.   | Page 17            |
|                               | Engine stops abruptly.                          | Out of fuel                                    | →Fill fuel.   | Page 17            |
|                               |   | Other (other than the above).                  | →Please contact your CANYCOM representative.  |                    |
|                               | Idling is not stable.                           | Insufficient intake air (clogged air cleaner). | →Clean or replace the air cleaner.  | Page 57            |
| Other (other than the above). |   | →Please contact your CANYCOM representative.   |   |                    |



| Area   | Malfunction  | Possible Cause  | Corrective Measure                           | Ref.    |
|--------|--|---|--|---------|
| Engine | Poor power or acceleration                             | Bad fuel  | →Change fuel.                                |         |
|        |  | Insufficient intake air (clogged air cleaner).          | →Clean or replace the air cleaner.           | Page 57 |
|        |  | Loose drive belt.                                       | →Adjust                                      | Page 63 |
|        |  | Excessive load  | →Reduce load.                                |         |
|        |  | Other (other than the above).                           | →Please contact your CANYCOM representative. |         |
|        | Irregular noise or vibration from or around the engine |   | →Please contact your CANYCOM representative. |         |
|        | Excessive oil consumption                              |   | →Please contact your CANYCOM representative. |         |
|        | Engine overheats                                       | Insufficient amount of engine oil.                      | →Fill oil.                                   | Page 55 |
|        |  | Rotating screen or cooling fins are clogged or blocked. | →Clean.                                      |         |
|        | Excessive fuel consumption                             | Clogged air cleaner.                                    | →Clean or replace the air cleaner.           | Page 57 |
|        |  | Other (other than the above).                           | →Please contact your CANYCOM representative. |         |
|        | Black smoke comes out of exhaust                       | Clogged air cleaner.                                    | →Clean or replace the air cleaner.           | Page 57 |
|        |  | Other (other than the above).                           | →Please contact your CANYCOM representative. |         |
|        | White or blue smoke comes out of exhaust               | Bad fuel.   | →Change fuel.                                |         |
|        |  | Engine oil level is too high.                           | →Adjust the oil level.                       | Page 55 |
|        |  | Wrong engine oil.                                       | →Change oil.                                 | Page 55 |
|        |  | Other (other than the above).                           | →Please contact your CANYCOM representative. |         |

| Area                          | Malfunction  | Possible Cause                               | Corrective Measure                           | Ref.    |
|-------------------------------|--|--|--|---------|
| Drive Train                   | Machine does not move when drive lever or pedal is operated.                         | Insufficient or deteriorated HST fluid.      | →Add or change fluid.                        | Page 61 |
|                               |  | Parking brake is applied                     | →Release the parking brake.                  |         |
|                               |  | V-belt is loose.                             | →Adjust V-belt.                              | Page 63 |
|                               |  | Other (other than the above).                | →Please contact your CANYCOM representative. |         |
|                               | Machine moves when drive lever or pedal is in neutral position.                      | HST is out of neutral.                       | →Please contact your CANYCOM representative. |         |
|                               | Transmission jumps out of gear.  | Transmission is not positively shifted.      | →Shift firmly.                               |         |
|                               |  | Other (other than the above).                | →Please contact your CANYCOM representative. |         |
|                               | Machine does not turn smoothly.  | Tires are not properly inflated.             | →Adjust tire pressure.                       | Page 59 |
|                               |  | Other (other than the above).                | →Please contact your CANYCOM representative. |         |
|                               | Machine does not run straight.   | Tie-rod is not properly adjusted.            | →Please contact your CANYCOM representative. |         |
| Other (other than the above). |  | →Please contact your CANYCOM representative. |  |         |
| Brake                         | Brake or parking brake does not work well, or machine pulls to one side when braked. | Brake is not proerly adjusted.               | →Adjust.                                     | Page 64 |
|                               |  | Brake is wet with water.                     | →Apply brake a few times to dry.             |         |
|                               |  | Other (other than the above).                | →Please contact your CANYCOM representative. |         |
| Chassis                       | Machine vibrates abnormally.   | Improperly inflated tires.                   | →Adjust tire pressure.                       | Page 59 |
|                               |  | Other (other than the above).                | →Please contact your CANYCOM representative. |         |

| Area   | Malfunction   | Possible Cause   | Corrective Measure                           | Ref.    |
|--|---|--|--|---------|
| Electrical System  | Head lamp does not illuminate properly.                   | Blown bulb.  | →Replace bulb.                               | Page 73 |
|  |   | Blown fuse.  | →Replace fuse.                               | Page 72 |
|  |   | Other (other than the above).                              | →Please contact your CANYCOM representative. |         |
| Cutting System   | Cutting blade does not rotate                             | Cutting rotary drive belt is severed.                      | →Replace.                                    |         |
|  | Cutting blade does not stop                               | Brake lining is worn.                                      | →Replace.                                    |         |
|  | Cutting rotary drive belt slips.                          | Belt is loose.   | →Adjust belt tension.                        | Page 68 |
|  |   | Belt is worn.  | →Replace.                                    | Page 68 |
|  |   | Cut grass or vines accumulate in the cutting blade shield. | →Clean.                                      | Page 75 |
|  | Abnormal vibration occurs when cutting blade is rotated.. | Cutting blade is damaged or lost.                          | →Replace cutting blades.                     | Page 65 |
|  |   | Foreign object is caught by cutting blade.                 | →Remove or clean foreign object.             |         |
|  |   | Other (other than the above).                              | →Please contact your CANYCOM representative. |         |
|  | Cut grass is not discharged properly.                     | Grass is wet.  | →Cut when grass is dry.                      |         |
|  |   | Grass is too long.   | →Cut in several steps at different heights.  |         |
|  |   | Cutting height is too low.                                 | →Raise cutting height.                       |         |
|  |   | Engine speed is too low.                                   | →Raise engine speed.                         |         |
|  |   | Driving speed is too high.                                 | →Drive slow.                                 |         |
|  | Some grass is left uncut.                                 | Grass is too long.   | →Cut in several steps at different heights.  |         |
|  |   | Engine speed is too low.                                   | →Raise engine speed.                         |         |
| Driving speed is too high.                                 |   | →Drive slow.   |  |         |
| Cutting blade is damaged or worn.                          |   | →Replace.  |  |         |
| Cut grass or vines accumulate in the cutting blade shield. |   | →Clean.  | Page 75                                      |         |

| Area           | Malfunction                     | Possible Cause  | Corrective Measure     | Ref. |
|----------------|---------------------------------|---|------------------------|------|
| Cutting System | Cutting blade cuts into ground. | Cutting height is too low.                            | →Raise cutting height. |      |
|                |                                 | Machine turns too fast.                               | →Turn slowly.          |      |
|                |                                 | Work site has undulations.                            | →Raise cutting height. |      |
|                |                                 | Cutting blade (knives or stay) is bent.               | →Replace.              |      |
|                | Cutter load is too high.        | Engine speed is too low.                              | →Raise engine speed.   |      |
|                |                                 | Driving speed is too high.                            | →Drive slow.           |      |
|                |                                 | Cut grass or vines are tangled to cutting blade axle. | →Untangle.             |      |

## Hauling

### Loading and Unloading

#### **⚠️ WARNING!**

- Park transporter (truck) on a level ground. Always apply parking brake and use chocks to secure wheels.
- Do not allow bystandars to come close to machine or transporter when loading or unloading machine.
- Use only loading ramps with sufficient strength (to withstand the combined weight of machine and operator), width (more than twice the width of tire.), and length (more than 4 times the height of loading deck of transporter), and have anti-slip ramp surfaces.
- Secure the hooks of loading ramps firmly and flush with loading deck.
- Move slowly forward when loading onto, and move slowly backward when unloading off of transporter. Pay special care when going over the joint between loading deck and ramps; machine may tip.
- Do not turn on loading ramps. Machine may fall.
- Tie down machine securely. Make sure machine does not move around.

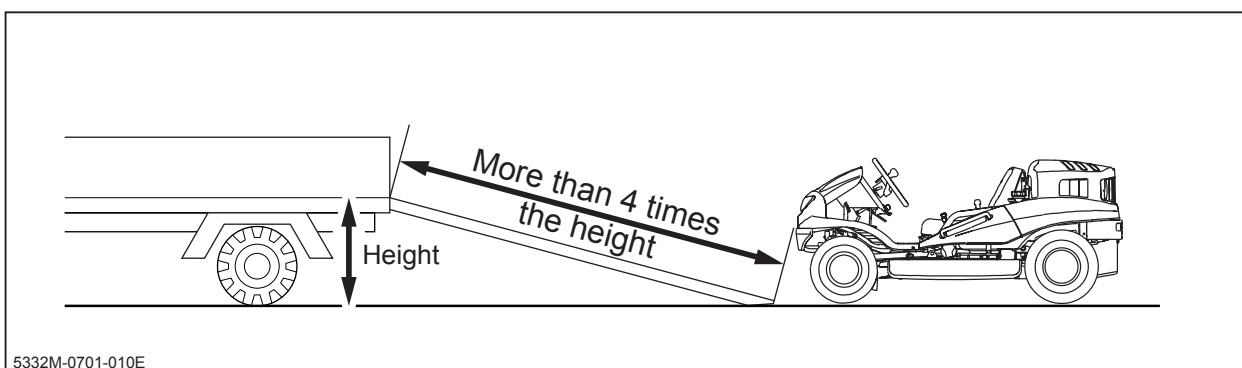

1. Park the transporter on a level ground. Apply parking brake and secure wheels with chocks.

2. Place loading ramps. Secure hooks of ramps firmly and flush with loading deck.
3. Shift auxiliary transmission shift lever to [Low] and drive machine slowly forward onto loading deck. Set cutting height adjust lever to [150] for CMX227, CM226, and [130] for CMX186, CM185. Pay attention not to hit loading lamp or loading deck when loading on a transporter.
4. Park machine according to the instructions in "**Parking**" (Page 32). Tie machine with rope or tie-down belts and secure it onto loading deck of transporter securely.

## Hoisting

### **⚠ WARNING!**

- Licence or certification is required to operate a crane. Check your local regulations.
- Use hoisting sling of sufficient strength. Always use the slings of the same length when more than one is used.
- Pay special attention to the center of gravity and the balance of machine when hoisting.

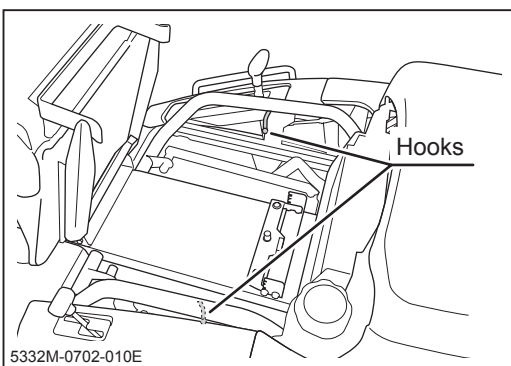

1. Lift seat.
2. Attach hoisting slings to 2 lift hooks and hoist machine.

### NOISE LEVEL

| Model<br>Type  | Engine       |           | LwA        |
|----------------|--------------|-----------|------------|
|                | Type         | Speed rpm |            |
| CMX227 / CM226 | Robin EH65DS | 3300 rpm  | 100 dB (A) |
| CMX186 / CM185 | Robin EH63DS | 3300 rpm  | 100 dB (A) |

NOISE LEVEL evaluated based on factory standard.

### VIBRATION

| Model          | Engine<br>Rated revolution | Vibration             |                         |                               |                      |
|----------------|----------------------------|-----------------------|-------------------------|-------------------------------|----------------------|
|                |                            | Mower Blade<br>Clutch | Steering<br>wheel (top) | Steering<br>wheel<br>(bottom) | Seat                 |
| CMX227 / CM226 | 3000 rpm                   | ON                    | 22 m/s <sup>2</sup>     | 20 m/s <sup>2</sup>           | 2.5 m/s <sup>2</sup> |
|                |                            | OFF                   | 13m/s <sup>2</sup>      | 18 m/s <sup>2</sup>           | 2.3 m/s <sup>2</sup> |
| CMX186 / CM185 | 3000 rpm                   | ON                    | 19m/s <sup>2</sup>      | 16m/s <sup>2</sup>            | 3.0m/s <sup>2</sup>  |
|                |                            | OFF                   | 11m/s <sup>2</sup>      | 16m/s <sup>2</sup>            | 2.6m/s <sup>2</sup>  |

VIBRATION evaluated based on factory standard.