



Click Here To View
Item at

www.GapPower.com

*Sales • Rentals
Parts & Service*

Operators Instruction Manual

SS-20 & SS-16A

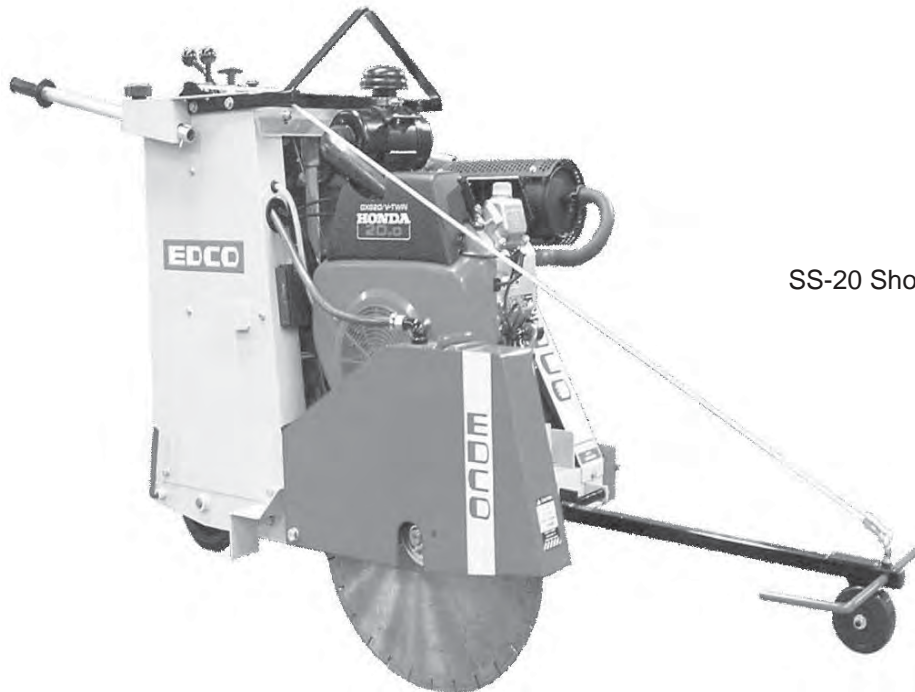

SS-20 Shown



Self Propelled Concrete/Asphalt Saw

READ AND UNDERSTAND THE OPERATORS INSTRUCTION MANUAL *THOROUGHLY* BEFORE ATTEMPTING TO OPERATE THIS EQUIPMENT.



Death or serious injury could occur if this machine is used improperly.



SAFETY MESSAGES

- Safety Instructions are preceded by a graphic alert symbol of DANGER, WARNING, or CAUTION.



Indicates an imminent hazard which, if not avoided, will result in death or serious injury.



Indicates an imminent hazard which, if not avoided, can result in death or serious injury.



Indicates hazards which, if not avoided, could result in serious injury and or damage to the equipment.

GASOLINE/PROPANE POWERED EQUIPMENT



- Engine exhaust from this product contains chemicals known to the State of California to cause cancer, birth defects or other reproductive harm.



- Gasoline is extremely flammable and poisonous. It should only be dispensed in well ventilated areas, and with a cool engine.

- Small gasoline engines produce high concentrations of carbon monoxide (CO) example: a 5 HP 4

cycle engine operation in an enclosed 100,000 cu. ft. area with only one change of air per hour is capable of providing deadly concentrations of CO in less than fifteen minutes. Five changes of air in the same area will produce noxious fumes in less than 30 minutes. Gasoline or propane powered equipment should not be used in enclosed or partially enclosed areas. Symptoms of CO poisoning include, headache, nausea, weakness, dizziness, visual problems and loss of consciousness. If symptoms occur get into fresh air and seek medical attention immediately.

ELECTRICAL POWERED EQUIPMENT



Extreme care must be taken when operating electric models with water present: Ensure power cord is properly grounded, is attached to a Ground-Fault-Interrupter (GFI) outlet, and is undamaged.

- Check all electrical cables - be sure connections are tight and cable is continuous and in good condition. Be sure cable is correctly rated for both the operating current and voltage of this equipment.
- Improper connection of the equipment-grounding conductor can result in a risk of electric shock. Check with qualified electrician or service person if there is any doubt as to whether the outlet is properly grounded. Adhere to **all** local codes and ordinances.
- **NOTE:** In the event of a malfunction or breakdown, grounding provides a path of least resistance for the electric current to dissipate. The motor is equipped with a grounded plug and must be connected to an outlet that is properly installed and properly grounded. **DO NOT** modify the plug provided on the motor. If the plug does not fit the outlet have a qualified electrician install the proper receptacle.
- Switch motor OFF **before** disconnecting power.

- Do not disconnect power by pulling cord. To disconnect, grasp the plug, not the cord.
- Unplug power cord at the machine when not in use and before servicing.

GENERAL INSTRUCTIONS

- Equipment should only be operated by trained personnel in good physical condition and mental health (not fatigued). The operator and maintenance personnel must be physically able to handle the bulk weight and power of this equipment.
- This is a one person tool. Maintain a safe operating distance to other personnel. It is the **operators' responsibility** to keep other people (workers, pedestrians, bystanders, etc.) away during operation. Block off the work area in all directions with roping, safety netting, etc. for a safe distance. Failure to do so may result in others being injured by flying debris or exposing them to harmful dust and noise.
- This equipment is intended for commercial use only.
- For the operator's safety and the safety of others, always keep all guards in place during operation.
- Never let equipment run unattended.



- Personal Protection Equipment and proper safety attire must be worn when operating this machinery. The operator must wear approved safety equipment appropriate for the job such as hard hat and safety shoes when conditions require. Hearing protection **MUST** be used (operational noise levels of this equipment may exceed 90db). Eye protection **MUST** be worn at all times.



Keep body parts and loose clothing away from moving parts. Failure to do so could result in dismemberment or death.

- Do not modify the machine.

- Stop motor/engine when adjusting or servicing this equipment.



Maintain a safe operating distance from flammable materials. Sparks from the cutting-action of this machine can ignite flammable materials or vapors.

DUST WARNING



Some dust created by power sanding, sawing, grinding, drilling, and other construction activities contains chemicals known to cause cancer, birth defects, or other reproductive harm. Some examples of these chemicals are:

- Lead from lead-based paints, and
- Crystalline silica from bricks and concrete and other masonry products.

Your risk of exposure to these chemicals varies depending on how often you do this type of work. To reduce your risk: work in a well ventilated area, use a dust control system, such as an industrial-style vacuum, and wear approved personal safety equipment, such as a dust/particle respirator designed to filter out microscopic particles.

Equipment Instruction Manual

EDCO Model SS-20 & SS-16A

Table of Contents

<u>Section</u>	<u>Page Number</u>
Safety Guidelines.....	4
Operating Instructions.....	5-8
Maintenance.....	9-14
Maintenance Schedule.....	15
Limited Equipment Warranty.....	back cover

Note:

Dimensions are approximate

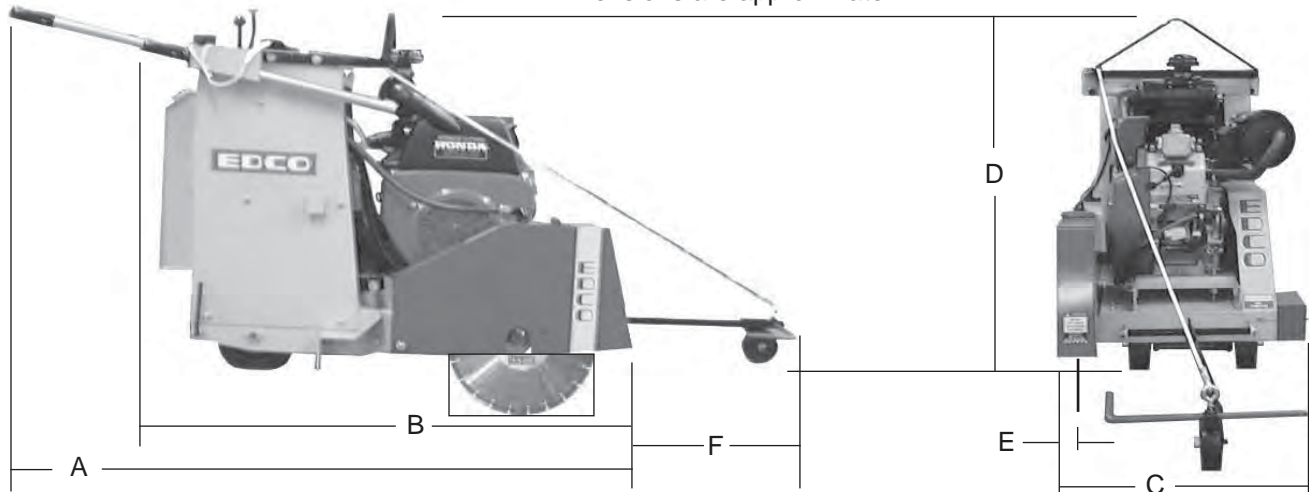

Figure 1

HOW TO ORDER REPLACEMENT PARTS

To insure product safety and reliability, always use genuine EDCO replacement parts when making repairs to the equipment.

When ordering parts, please specify the MODEL and SERIAL NUMBER of the machine as given on the NAMEPLATE. In addition, give part number, description and quantity as listed on the parts list.

Please note: Due to improvements and changes in the equipment the illustrations shown may be different from the actual machine.

Toll Free: Voice 1-800-638-3326 • Fax 1-800-447-3326

Model#	SS-20	SS-16A
A (handles extended)	79" 201cm	79" 201cm
B (handles retracted)	45 1/2" 116cm	45" 114cm
C	24" 61cm	24" 61cm
D	39" 99cm	37 1/2" 95.25cm
E	2" 5.1cm	2" 5.1cm
F	19 1/4" 49cm	19 1/4" 49cm
Fuel Tank	3 Gal 11 Liters	1.72 Gal 6.5 Liters
Weight	480 lbs. 218kg	355 lbs. 161kg



100 Thomas Johnson Drive, Frederick, MD 21702-4600 USA
 Phone (301) 663-1600 • 1-800-638-3326
 Fax (301) 663-1607 • 1-800-447-3326
 Website: www.edcoinc.com
 Email: sales@edcoinc.com

Printed in USA

©2007

Page 3



Read and understand the *Operator's Manual*, the *Rx for Concrete Saws*, and the *Engine Manufacturer's Owner's Manual* before operating this equipment.
Death or serious injury can result if this machine is used improperly.



Safety Guidelines



Maintain a safe operating distance from flammable materials. Sparks from the cutting-action of this saw can ignite flammable materials or vapors.



Operator must wear appropriate clothing and footwear. Do not wear loose clothing or jewelry that can get tangled or caught in moving parts.



Eye and ear protection must be worn at all times when this machine is in use. During normal use, sound levels exceed 92dB. Use only ANSI approved safety glasses to help prevent eye injury. Everyday eyeglasses have only impact resistant lenses; they are NOT safety glasses.

- Keep a safe operating distance from other personnel and never leave the machine running unattended.
- Maintain the machine in safe operating condition with all guards in place and secure, all mechanical fasteners tight, all controls in working order and the saw configured for the job application.
- The SS-20 is designed to cut flat, horizontal concrete or asphalt slabs using diamond saw blades.
- The SS-20 is to be operated by a single operator from a position at the rear of the saw.
- Avoid deck inserts, pipes, columns, openings, electrical outlets, or any objects protruding from slab surface.
- Inspect the blades carefully before installing. Do not use any questionable blade since serious personal injury and/or damage to property can result.
- Never operate this saw while under the influence of drugs, alcohol or when taking medications that impair the senses or reactions, or when excessively tired or under stress.
- Be sure all safety decals on the machine can be clearly read and understood. Replace damaged or missing decals immediately.

Safety warnings and guidelines do not by themselves eliminate danger. They are not given as substitutes for proper accident prevention and good judgement.

Operating Instructions

1 - Emergency Stop (E-Stop): PUSH to shut off the engine in an emergency. Before operation, be sure the E-Stop is reset by lifting the knob. **CAUTION:** Do not use the E-Stop as an ON/OFF switch in place of the ignition. If the ignition is left on, it will drain the battery.

2 - Choke: Use to aid cold weather engine starting. Follow the instructions in the *Engine Owner's Manual*. *

3 - Ignition Switch: Turn key to START position. Once engine starts, leave in RUN position. Shut off Ignition Switch between uses. As a safety precaution, remove key when not in use. *

4 - Throttle: Turn COUNTER CLOCKWISE to unlock. PULL UP to increase engine RPM, PUSH DOWN to decrease. Turn CLOCKWISE to lock cable in position once desired engine speed is reached.

5 - Blade Saver Switch: Must be in the DRY position or engine will not start. The purpose of the Blade Saver is to stop the engine if water pressure drops. If using a WET CUT Blade, open the water valve and select the WET position after starting the engine and before starting to cut. *

6 - Water Pump Switch: (Optional) Activates pump to pull water from an external tank when city water source is not convenient or available. *

7 - Depth Gauge: Provides readout of blade depth. *

8 - Depth Control Handwheel: Raises and lowers the blade.

9 - Speed Control: Controls saw speed in FWD and REV. This EDCO saw is equipped with a Hydrostatic Transmission, which permits infinite speed control. (Actual cutting speed is limited by the saw blade and cutting conditions).

10 - Clutch: Pull back to engage DRIVE. Push forward to release drive wheels (Freewheel) SS-20. Push right to engage DRIVE. Push to left to release drive wheels, SS-16A only.

11 - Hour Meter: Gives readout of engine run-time. One suggested use for this meter is to keep track of scheduled maintenance. (See page 11)

12 - Handle Locks: Loosen knobs to adjust handle position. Be sure to securely retighten the knobs once handles are positioned. Adjust before starting saw for operator comfort and safe operation.

13 - Guide Rope: Provides raising and lowering of cutting guide.

14 - Guide Rope Cleat: Locks Guide Rope during transit or storage. *

Note: Numbers coincide with the *Guide To Operation* label on the SS-20 machine only.

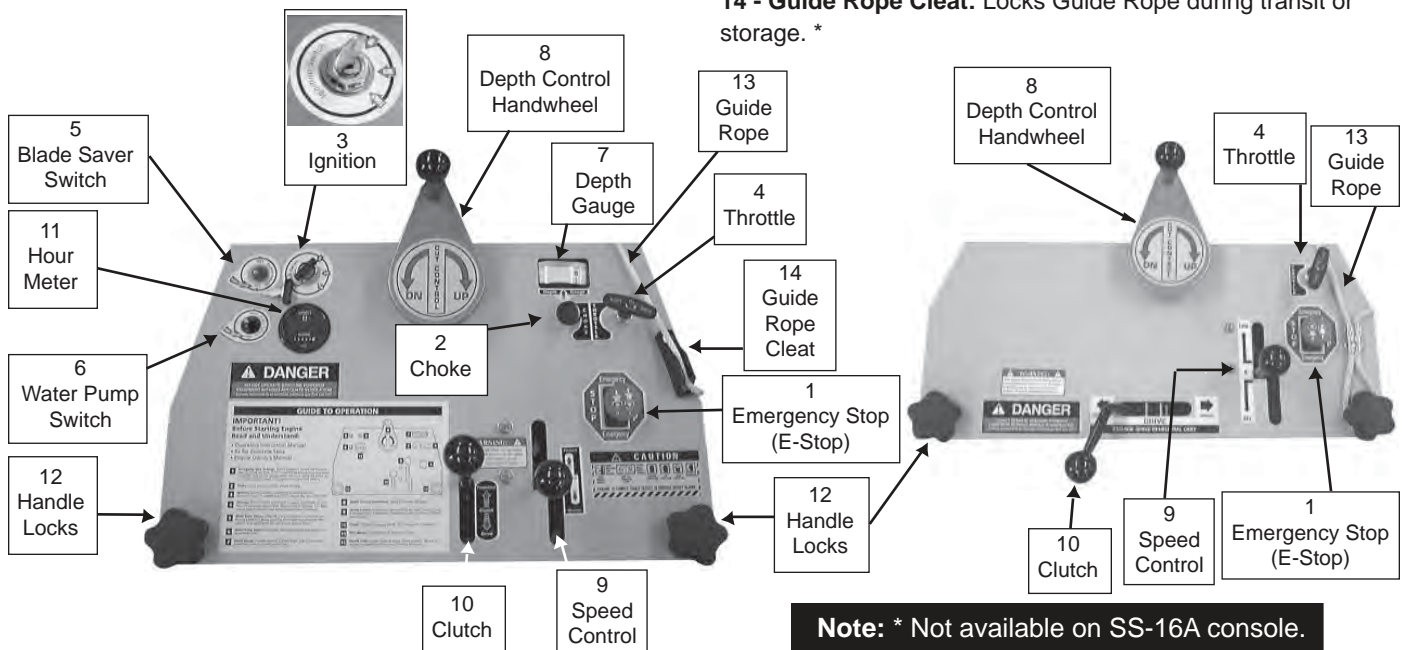

Figure 2

Before Starting the Engine:

- Read *Rx for Concrete Saws* before operating.
- Inspect machine before each use according to the *Maintenance Schedule* on page 15.
- Locate and be familiar with all engine and saw controls (*Figure 2*).
- Inspect the blades carefully before installing. Use the correct blade for the job. Check rated RPM, diameter and size configuration. Make sure blades are correctly mounted.
- For wet cutting, attach supply hose to Water Hook Up Valve (*Figure 3*).
- **NOTE:** Do not flip Blade Saver switch to WET until after the engine has started.
- Adjust the handles for operator comfort and safe operation. Be sure to retighten knobs once handles are positioned.
- Be sure cutting line is well defined.
- Move the saw into operating position.

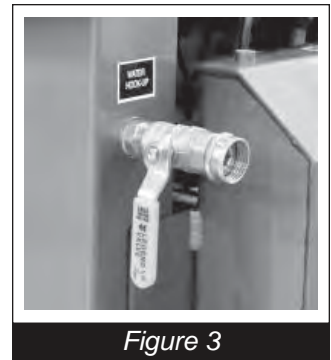

Figure 3

Starting the Engine:

- Check to be sure blade is raised - not in contact with the slab surface and blade guards are in place.
- Blade Saver switch (*Figure 4*) must be in the DRY position or engine will not start.
- **Note:** The Blade Saver detects water pressure from the switch to the blade. If water pressure drops below 2 1/2 gallons per minute, the switch will shut off the engine to prevent damage to the machine and/or the blade.
- Check that the Emergency Stop (E-Stop) is in the UP position.
- Turn Engine Ignition key to START. After engine starts, leave Engine Ignition in the RUN position. Ignition position on saw will vary depending on engine. (Review *Figure 2*)
- **NOTE:** In cold weather, use the Choke to aid starting.
- If wet cutting, open Water Valve (or turn on Water Pump) then flip the Blade Saver switch to the WET position. Check to be sure water flows freely to the blade. Water should be visible on the ground around the blade.

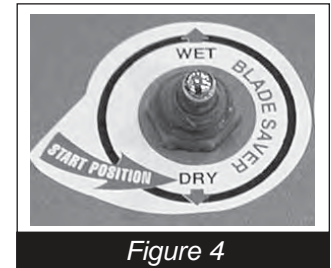

Figure 4



SS-20 only. For blades marked DRY CUTTING, leave switch in the DRY position. While water is not required for cooling, it may be used for controlling dust. For health reasons, it is strongly recommended that the operator wear a respirator if cutting dry and water is not being used to control dust from the material being removed. That dust may contain chemicals known to cause serious illnesses, including Silicosis a fatal disease of the lungs. Check the chemical properties of the material to be removed and follow all EPA/OSHA regulations.

For Electric Models:

- Be sure the “STOP” (red) button is depressed (*Figure 4A*). Hook up the electrical power source by plugging into the connector provided. If the cord does not mate with the connector, consult a qualified licensed electrician before continuing. Be Sure the equipment is properly grounded.
- After completing the previous step, to start the motor, be sure the Emergency Stop (E-Stop) is in the UP position (*Figure 2*). Press the “START” (green) button (*Figure 4A*).
- Allow motor to reach operating speed.

“Start” Button Green)

“Stop” Button (Red)

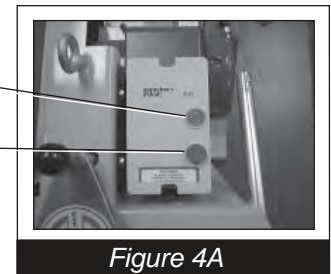

Figure 4A

Wet Cutting Only: Maximum Depth of Cut	SS-20	SS-16A
for 14" diameter blade.....	4 3/4"	4 3/4"
for 16" diameter blade.....	5 3/4"	5 3/4"
for 18" diameter blade.....	6 3/4"	
for 20" diameter blade.....	7 3/4"	

Figure 5

For Dry Cutting:
Consult Blade Manufacturer
for Maximum Depth of Cut.

Starting and Controlling the Cut:

- Engine must be at FULL THROTTLE.
- Move CLUTCH lever to DRIVE position and adjust SPEED CONTROL (*Figure 8*).
- Pull knob up on the Depth Control Handwheel (*Figure 6*), slowly turn Handwheel in DOWN direction (counter clockwise) until blade comes in contact with slab surface.
- Set the Depth Gauge (*Figure 7*) at ZERO .
 - Continue turning the Handwheel until blade has penetrated the slab to desired depth.

CAUTION

Note: Depth gauge is an approximate measurement - it is not exact.

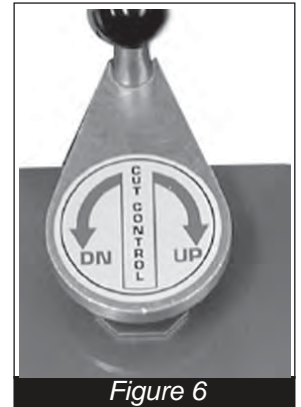

Figure 6

Never cut deeper than the maximum depth of cut for the blade being used.
Only cut in a forward direction.
Always cut with the engine at full throttle.

Controlling Speed:

- The SS-20 and SS-16A uses a hydrostatic transmission, chain and friction drive mechanism that engages both rear wheels to achieve forward and reverse movement. Machine speed is controlled by using the Speed Control lever.
Actual cutting speed is determined by type of blade, material to be cut and depth of cut. Adjust forward speed to meet cutting conditions.

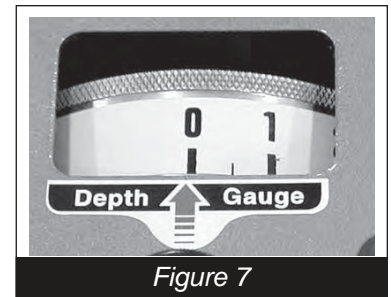

Figure 7

CAUTION

Note: If while cutting, the front wheels start to lift, reduce forward speed.

For positioning the saw, the maximum forward speed is 200ft. per minute. For safety reasons when in reverse, the SS-20 and SS-16A is designed to move at a slow walking pace. *Do not force it to go faster.*

Left or Right Side Cutting:

- If circumstances require a left side cut, see page 11 for instructions on moving the blade and blade guard.



Figure 8



To Stop Cutting:

- Move Speed Control lever to the NEUTRAL position.
- Turn Depth Control Handwheel clockwise until blade is clear of slab.
- Push Clutch Lever forward, away from operator to the FREE WHEEL position; this will stop all forward motion. (Figure 8)
- Return Throttle to idle.
- Flip Blade Saver switch back to DRY.
- Turn off optional Water Pump then turn off water supply valve.

To Stop the Engine:

- In an emergency situation, PUSH DOWN the E-Stop.
- For normal shut off, return Ignition to OFF position and remove the key, SS-20 only.

NOTE: Using the E-Stop as an ON/OFF switch instead of shutting off the ignition will drain the battery, SS-20 only.

Coolant Requirements:

- Water *must* be used when operating with blades marked for WET CUTTING. A supply of 2 1/2 - 5 gallons per minute (GPM) is necessary. Attach water hose to Coolant Valve or Pump. Adjust valves to control the flow of water.

Optional Electric Water Pump Operation:

- On all models equipped with Electric Pumps (12 V.D.C.), be sure there is water in the system AND water is being supplied to the pump, SS-20 only.
- Attach the water hose to the valve.
- Start the engine according to the directions on page 6.
- Open water valve then turn the Water Pump switch ON and the Blade Saver to WET. (Review Figures 3 & 4)
- To stop water flow, SS-20 only, turn the Blade Saver back to DRY and then the Water Pump switch to OFF. Close the water valve. Never interrupt the flow of water to the pump while the pump is ON. Stopping the flow of water to or from the pump while it is ON may cause a blown water pump fuse. Should the water pump fuse blow, see directions for *Changing the Water Pump Fuse* page 9.

NOTE: For units with the optional Water Pump, water flows through the pump assembly at all times. If pressure from outside source such as city water supply is adequate (2 1/2 - 5 gallons per minutes), Water Pump need not be engaged.

Transporting the Saw:



Extreme care must be taken when loading or unloading this machine.

- If hoisting this machine, use the built in hoisting bar. (Figure 9) Use proper hoisting equipment and techniques.
- Remove the blade before transporting or hoisting. Serious personal injury or damage to the equipment can result.
- Do not transport the saw with the engine running.
- Be certain the area surrounding the machine is clear of personnel before hoisting.

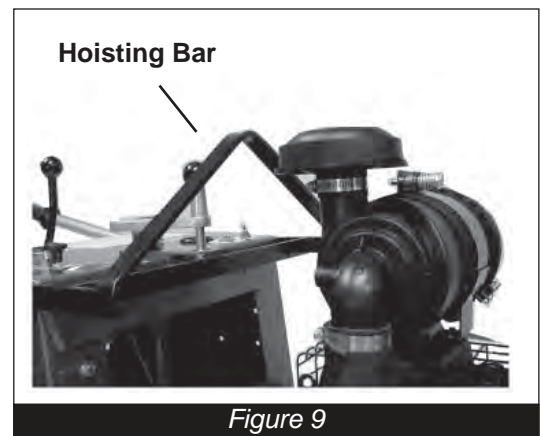

Figure 9



The following maintenance instructions are brief explanations of some of the items suggested in the Maintenance Schedule chart on page 15. These instructions are not replacements for the *Engine Manufacturer's Maintenance Instructions*.



Maintenance

Should the Engine Stop While Operating:

- Check water supply, SS-20 only:
 - a. Is city water valve fully open?
 - b. Is valve on saw console open?
 - c. If you are using gravity feed, check the flow.
 - d. If using a tank, is it empty?
- Check fuel level in the gas tank. Do not over fill the gas tank and never refuel a hot engine. If refueling is necessary during operation, allow the engine to cool down first.
- Check oil level. **Note:** Some engines are equipped with an oil pressure switch that shuts off the engine in the event the oil level drops below acceptable levels.
- Was the E-Stop accidentally pushed in?
- After determining and fixing source of the problem, follow all of the *Starting the Engine* instructions on page 6. If none of the above situations correct the problem, discontinue use and contact a qualified repair professional.

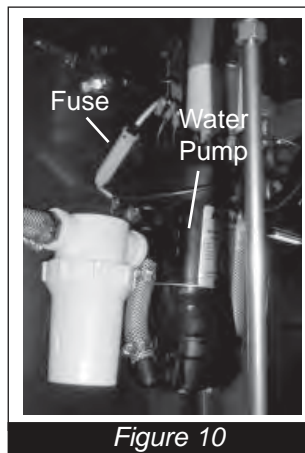

Figure 10

Changing the Water Pump Fuse:

The Water Pump Fuse is located inside saw unit. (Figure 10)

- To access it, unscrew the bolt and open the gas tank door.
- Reach in and find the fuse cap. It is located in front of the water pump.
- Twist and pull apart the cap and remove the fuse.
- Replace it with a AGC10 250V or equivalent fuse

Before Changing Blades:



Inspect all blades carefully before installing. Check for cracks, loose segments and oversize, worn, or out-of-round arbor holes (See page 13). Do not use **any** questionable blade since serious personal injury and/or damage to property can result. Do not use warped, twisted, or out-of-balance blades. Unbalanced blades will wear excessively, vibrate and damage both arbor shaft and bearings.



For safety reasons, EDCO **does not** recommend the use of any abrasive blades. Abrasive blades can break and cause serious personal injury to operator and/or bystanders. If abrasive blades are used by choice, only use those which are marked as *reinforced* abrasive blades.

- Make sure you have the proper blade for the job. Determine the hardness and composition of the slab. Give your dealer complete information including whether re-bars are present, the desired depth of the cut, and the length of the cut. If in doubt, contact the blade manufacturer. Never exceed the maximum operating speed of the blade. Be sure to match the blade speed rating with the arbor shaft speed on the machine.



Do not remove or lift the bladeguard unless blade has stopped completely and the engine is off.

Changing Blades:

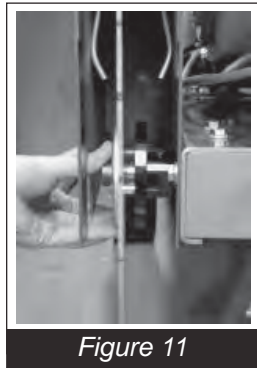

Figure 11

- Raise blade guard and remove arbor shaft nut, washer and blade retaining cap. (Figure 14) Both the arbor shaft nut and the flat of the backing plate require a 1 1/2" wrench two are provided with the machine.
- Clean the arbor shaft, backing plate, and blade cap and inspect for damage or wear. Make sure the arbor shaft threads are clean and undamaged. If any damage is detected, consult your EDCO dealer or the EDCO factory.
- Carefully place the blade on the arbor shaft and turn until the drive pin lines up with the hole in the backing plate. (Figure 11) Do not use a blade without a drive pin.
- Fit the washer and arbor shaft nut and retighten the nut using the two 1 1/2" wrenches. (Figures 12 & 13)
- Secure the blade guard in the operating position before starting engine.



Figure 13



Figure 12

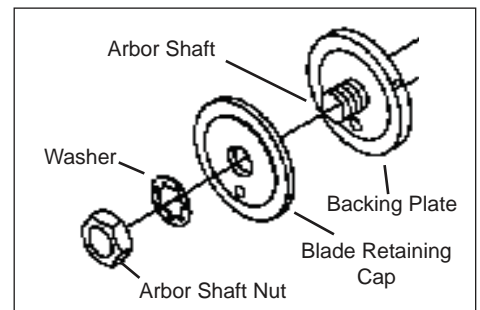
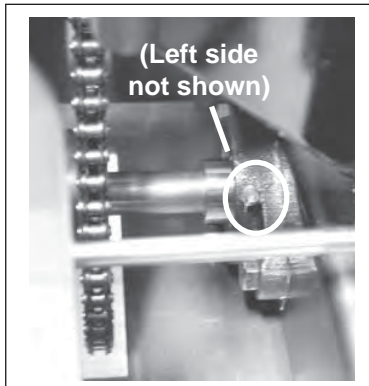

Figure 14



Drive Axle Bearings (2)

⚠ Important! ⚠
Arbor Shaft Bearings *MUST* be lubricated EVERY FOUR HOURS!



Depth Control Handwheel Bearing (1)

Grease Bearings - (9 Total)

Arbor Shaft Bearings (2) **must** be greased every 4 hours.

All other Bearings (7) must be greased every 40 hours.

Those include:

Front Fork Bearings (2), Rear Wheel Bearings (2), Drive Axle Bearings (2), and the Depth Control Wheel Bearing (1).

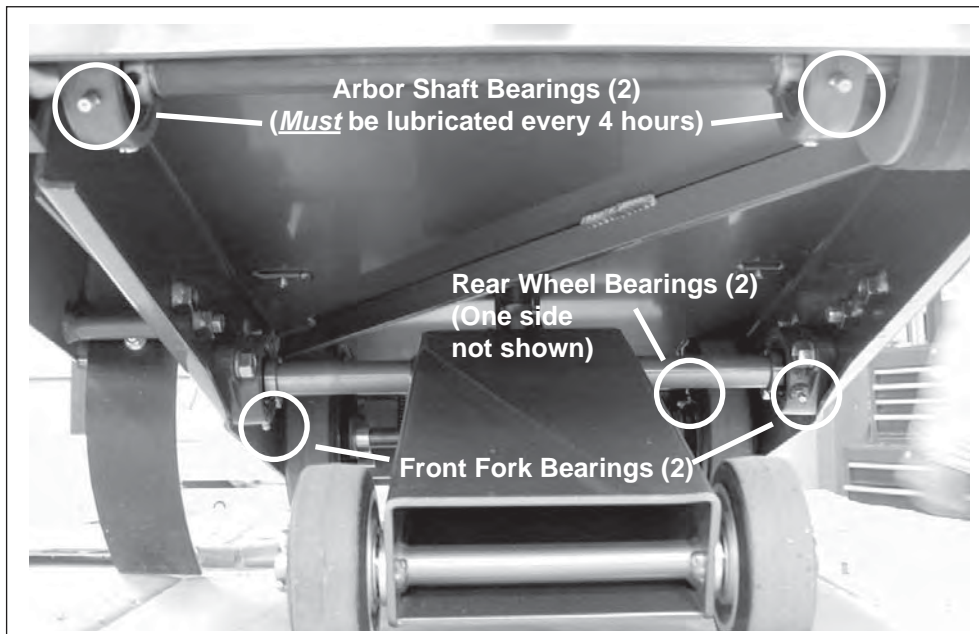

Arbor Shaft Bearings (2), Rear Wheel Bearings (2), Front Fork Bearings (2)

Check Engine Oil Before Each Operation -

Check Engine Manufacturer's Owner's Manual for specific instructions.

Change Oil & Filter Every 50 Hours of Operation (Sooner if Necessary).

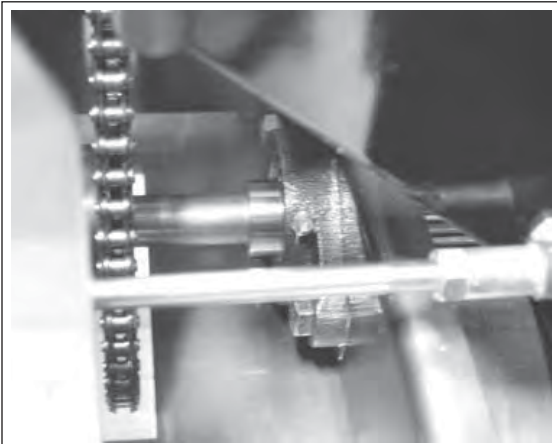

Drive Chain

Check Drive Chains Before Operation - Lubricate Weekly

Open gas tank door -
Drive chain is just inside, on the right.

Inspect/adjust Arbor Drive and Drive Belts -

On new machines and after installation of new belts, adjust belt tension after the first four hours, then as necessary.

Loosen engine mount bolts (2)
turn jacking bolt to lift engine mount. (1)

Note:

To change the drive belt, the engine must be slid forward. Loosen the engine bolts (4) that hold the engine to the mount and slide the engine forward to its original position. Retighten the engine bolts and follow the directions above to retighten the arbor belts.

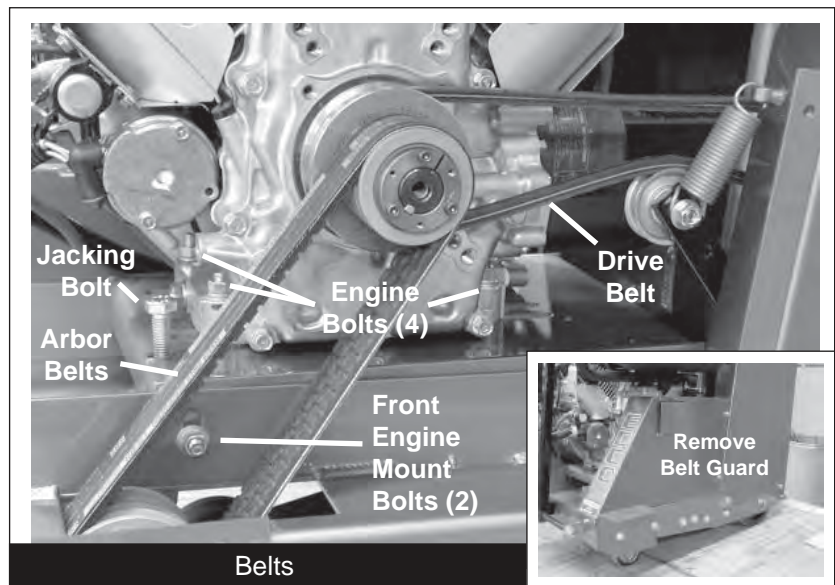

Changing To Left-Side Cutting:

- Disconnect water hose from the blade guard.
- Using SAE 9/16" and 3/4" wrenches, remove the bolts on the blade guard.
- On the other side of the machine, remove the arbor shaft guard.
- You will have to re-route the water hose to the other side of the engine. It may be necessary to pull the hose back through the hole in the main body of the machine and allow it to run directly up the left side. Be sure that the hose will not interfere with or get caught on any moving parts.
- Reattach both guards.
- Reattach hose to the blade guard.



Left Side Arbor Shaft Guard



Blade Guard

Possible Diamond Blade Problems

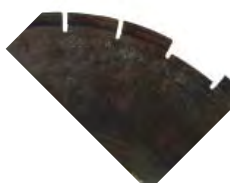

Segment Loss:
Usually insufficient
water



**Arbor Hole
Out-Of-Round**
Blade not properly tightened
or seated on arbor.



**Cracked Segments
and/or Core**
Wrong Blade for the job.

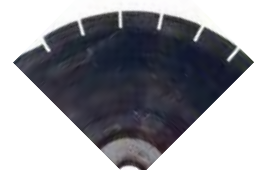

Blade Will Not Cut:
Blade is glazed or
too hard for the job.

Possible Diamond Blade Problems

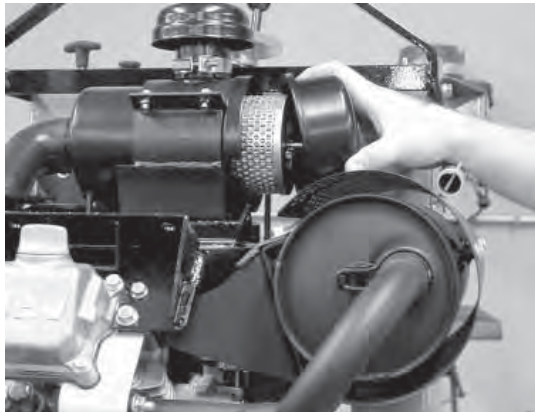

Air Filter

Inspect and Clean Air Filter Element Daily -

(Shown with Honda Engine)

Replace when necessary with factory parts.

Refer to the *Engine Manufacturer's Owner's Manual* for specific requirements.

Inspect Transmission Fluid Level -

Every 50 hours of operation - fill as required.

The fill level line is located on the fill spout.

Fill using GM dexron B or comparable fluid.

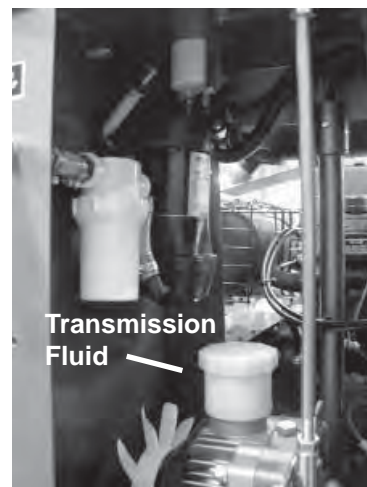

Transmission Fluid

Transmission Fluid

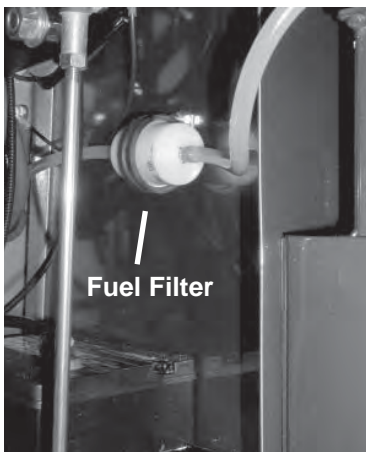

Fuel Filter

Fuel Filter

Replace Fuel Filter -

As required. Refer to the *Engine Manufacturer's Owner's Manual* for specific requirements.

On Kohler engines, the fuel filter is mounted in the console, as shown in the photo on the left.

On Honda engines, the fuel filter is located on the engine.

Maintenance Schedule



Repairs are to be done by authorized EDCO DEALERS only.



Read and follow instructions in the Engine Manufacturer's Manual

Follow Engine Manufacturer's Maintenance Schedule	Before Each Operation	Every 4 Hours	Daily	Every 40 Hours of Operation	Every 50 Hours of Operation	As Required
Visual Inspection of Entire Machine	X					
Inspect Blade	X					
Inspect Arbor Shaft	X					
Check Engine Oil	X					
Grease <u>Arbor Shaft</u> Bearings		X				
Clean Air Filter Element			X			
Grease Remaining Bearings				X		
Change Engine Oil & Filter (Sooner if necessary)					X	
Check Transmission Fluid Level					X	
Inspect Drive Chains (Lubricate Weekly)						X
Replace Fuel Filter						X
Inspect Belts (Tension after the first 4 hours, then)						X

LIMITED EQUIPMENT WARRANTY OF SALE – TERMS & CONDITIONS

Equipment Development Company, Inc. herein referred to as EDCO (Seller) warrants that each new unit manufactured by EDCO to be free from defects in material and workmanship in normal use and service for a period of (1) one year (except for the cutter drum assembly on all model concrete/asphalt planes, in which case the warranty period shall be 90 days) and (VAC motors, in which case the warranty period shall be (2) two years) from date of shipment to the original retail or equipment rental center owner.

Accessories or equipment furnished and installed on the product by EDCO but manufactured by others, including, but not limited to engines, motors, electrical components, transmissions etc., shall carry the accessory manufacturers own warranty.

EDCO will, at its option, repair or replace, at the EDCO factory or at a point designated by EDCO, any part which shall appear to the satisfaction of EDCO inspection to have been defective in material or workmanship.

EDCO reserves the right to modify, alter and improve any part or parts without incurring any obligation to replace any part or parts previously sold without such modified, altered or improved part or parts.

This warranty is in lieu of and excludes all other warranties, expressed, implied, statutory, or otherwise created under applicable law including, but not limited to the warranty of merchantability and the warranty of fitness for a particular purpose in no event shall seller or the manufacturer of the product be liable for special, incidental, or consequential damages, including loss of profits, whether or not caused by or resulting from the negligence of seller and/or the manufacturer of the product unless specifically provided herein. In addition, this warranty shall not apply to any products or portions thereof which have been subjected to abuse, misuse, improper installation, maintenance, or operation, electrical failure or abnormal conditions and to products which have been tampered with, altered, modified, repaired, reworked by anyone not approved by seller or used in any manner inconsistent with the provisions of the above or any instructions or specifications provided with or for the product

FORCE MAJEURE

Seller's obligation hereunder are subject to, and Seller shall not be held responsible for, any delay or failure to make delivery of all or any part of the Product due to labor difficulties, fires, casualties, accidents, acts of the elements, acts of God, transportation difficulties, delays by a common carrier, inability to obtain Product, materials or components or qualified labor sufficient to timely perform part of or all of the obligations contained in these terms and conditions, governmental regulations or actions, strikes, damage to or destruction in whole or part of manufacturing plant, riots, terrorist attacks or incidents, civil commotions, warlike conditions, flood, tidal waves, typhoon, hurricane, earthquake, lightning, explosion or any other causes, contingencies or circumstances within or without the United States not subject to the Seller's control which prevent or hinder the manufacture or delivery of the Products or make the fulfillment of these terms and conditions impracticable. In the event of the occurrence of any of the foregoing, at the option of Seller, Seller shall be excused from the performance under these Terms and Conditions, or the performance of the Seller shall be correspondingly extended.

This document sets forth the terms and conditions pursuant to which the purchaser ("Purchaser") will purchase and Equipment Development Co. Inc. ("Seller") will sell the products, accessories, attachments (collectively the Products) ordered by the Purchaser. These terms and conditions shall govern and apply to the sale of Seller's Products to Purchaser, regardless of any terms and conditions appearing on any purchase order or other forms submitted by Purchaser to Seller, or the inconsistency of any terms therein and herein.

1. PRICE

All prices set forth on any purchase order or other document are F.O.B. Sellers facility or distribution point, as may be determined by Seller (F.O.B. Point). All prices are exclusive of any and all taxes, including, but not limited to, excise, sales, use, property or transportation taxes related to the sale or use of the Products, now or hereafter imposed, together with all penalties and expenses. Purchaser shall be responsible for collecting and/or paying any and all such taxes, whether or not they are stated in any invoice for the Products. Unless otherwise specified herein, all prices are exclusive of inland transportation, freight, insurance and other costs and expenses relating to the shipment of the Products from the F.O.B. point to Purchaser's facility. Any prepayment by Seller of freight insurance and other costs shall be for the account of Purchaser and shall be repaid to Seller.

2. PAYMENT TERMS

Payment terms are as follows. 2% 10 days (to approved and qualified accounts). Net 30 days. This is a cash discount for invoices paid within 10 days after the invoice date, regardless of date of receipt of shipment. This is not a trade discount and will not be granted to accounts that do not adhere to stated terms.

*All past due accounts are subject to a late payment fee of 1.5% per month or a maximum allowed by law if different, along with the expenses incidental to collection including reasonable attorney's fees and costs.

*Seller reserves the right to hold shipments against past due accounts.

*Seller reserves the right to alter payment terms.

3. FREIGHT TERMS

All shipments will be made F.O.B. shipping point as designated in these Terms and Conditions, and title shall pass at the F.O.B. point. Delivery to the initial common carrier shall constitute delivery to the Purchaser. Any claims for loss or damage during shipment are to be filed with carrier by the Purchaser. Seller will not assume responsibility for the performance of the carrier.

Back orders will be shipped in the most practical fashion with charges consistent with our freight policy established with the original order. UPS, FED EX, MAIL or shipments by other couriers are subject to the same terms and conditions as outlined in paragraph #3 "Freight Terms".

4. DELIVERY, DAMAGES, SHORTAGES

Seller shall use reasonable efforts to attempt to cause the Products to be delivered as provided for in these Terms & Conditions. Delivery to the initial common carrier shall constitute the delivery to the Purchaser. Seller's responsibility, in so far as transportation risks are concerned ceases upon the delivery of the Products in good condition to such carrier at the F.O.B. point and all the Products shall be shipped at the Purchaser's risk. Seller shall not be responsible or liable for any loss of income and/or profits, or incidental, special, consequential damages resulting from Seller's delayed performance in shipment and delivery.

5. RETURN OF DEFECTIVE PRODUCTS

Defective or failed material shall be held at the Purchaser's premises until authorization has been granted by Seller to return or dispose of Products. Products that are to be returned for final inspection must be returned Freight Prepaid in the most economical way. Credit will be issued for material found to be defective upon Seller's inspection based on prices at time of purchase.

6. PRODUCTS ORDERED IN ERROR

Products may be returned, provided that claim is made and Seller is notified within 7 days of receipt of Products, and the Products are in original buyer's possession not more than 30 days prior to return, subject to Seller's approval. If Products are accepted for return, they must be Freight Prepaid and buyer will be charged a minimum of 15% rehandling charge, plus a charge back for outbound freight charges if the original order was shipped prepaid. Returns are not accepted for any Products that are specifically manufactured to meet the buyer's requirement of either specifications or quantity.

AGREEMENTS

These Terms and Conditions constitute the entire agreement between Seller and Purchaser as it relates to terms and conditions of sale, and supersedes any and all prior oral or written agreements, correspondence, quotations or understandings heretofore in force between the parties relating to the subject matter hereof. There are no agreements between Seller and Purchaser with respect to the Product herein except those specifically set forth in and made part of these terms and conditions. Any additional terms, conditions and/or prices are rejected by Seller.

These terms and conditions may be modified, cancelled or rescinded only by a written agreement of both parties executed by their duly authorized agents.

USE ONLY GENUINE EDCO PARTS & ACCESSORIES
For your own safety, the safety of others and the life of your machine.

Equipment Development Company, Inc.