

RAMMER 555E



EXCELLENCE LINE

FACTORY
INSTALLED
RD3 FOR
MYFLEET

CBE (CONSTANT
BLOW ENERGY)

MEMBRANE TYPE
ACCUMULATORS

SINGLE BODY DESIGN
WITHOUT TIE RODS

INTEGRATED TOOL BUSHINGS
AND THRUST RING (3 IN 1)

EXCELLENCE LINE HITS SMARTER

The Rammer Excellence Line is a set of state-of-the-art hydraulic hammers for all your rock breaking needs. All Excellence Line hammers now have integrated smart technology for easier fleet management and more efficient processes.

Read more about the product from
www.rammer.com/excellence

**Ram
mer**[®]

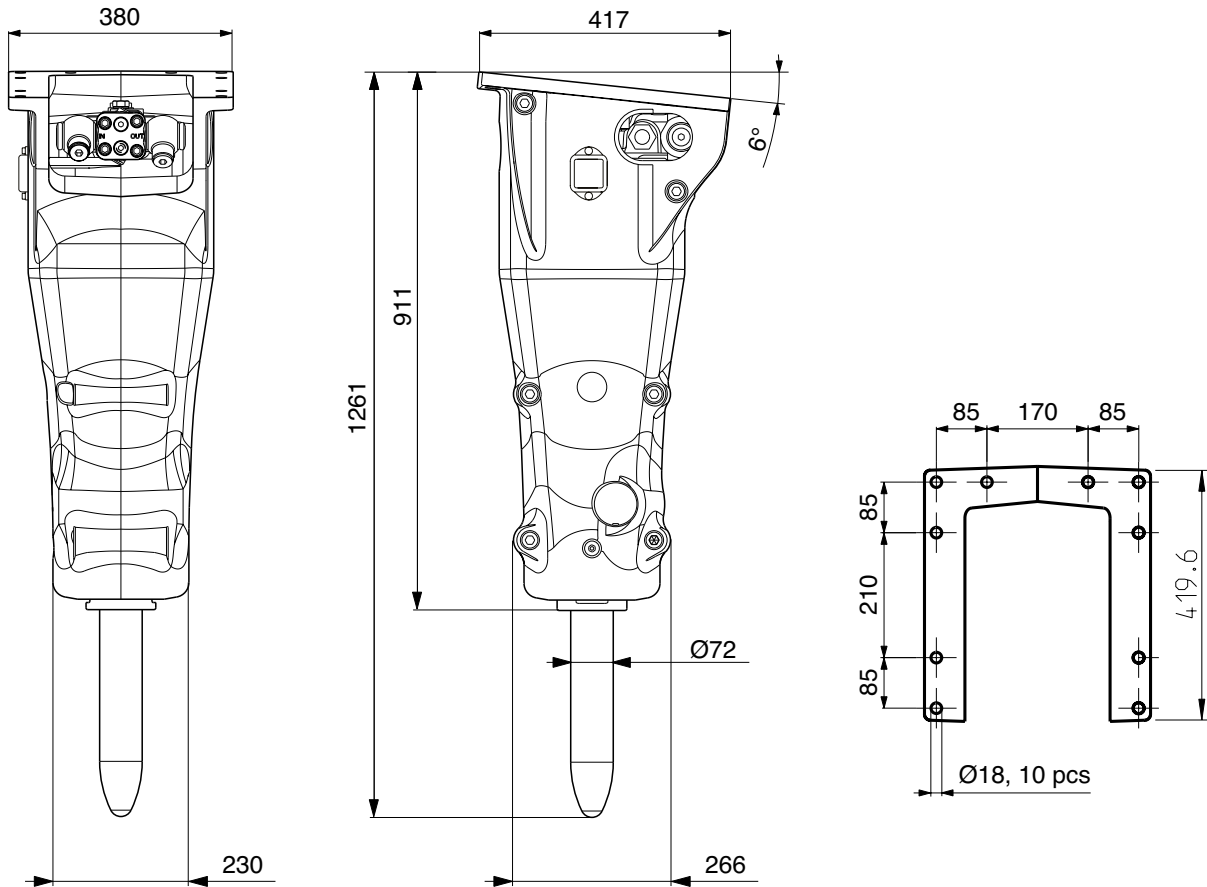

SPECIFICATIONS

Minimum working weight, flange mounted, kg (lb)	275 (610)
Impact rate, bpm	600-1800
Operating pressure, bar (psi)	90-140 (1305-2030)
Pressure relief, max bar (psi)	220 (3190)
Oil flow range, l/min (gal/min)	35-90 (9.2-23.8)
Back pressure, max bar (psi)	20 (290)
Input power, kW (hp)	21 (28)
Tool diameter, mm (in)	72 (2.83)
Miniexcavator weight, allowed range t (lb)	3.2-8.0 (7100-17600)
Skid steer, robot weight, allowed range t (lb)	1.9-5.3 (4200-11700)
Noise level, measured sound power level, LWA dB	118
Noise level, guaranteed sound power level, LWA dB	122

TOOLS

Chisel	Spade
Pyramid	Compacting plate
Moil point	

PARTS

Service kit 1
Special tool grease

Sandvik Mining and Construction Oy
 Taivalkatu 8, P.O.Box 165
 FI-15101 Lahti, Finland
 Phone Int. +358 205 44 151
 rammer@sandvik.com
 www.rammer.com



Rammer[®]