



[Click Here To View](#)  
[Item at](#)

[www.GapPower.com](http://www.GapPower.com)

*Sales • Rentals  
Parts & Service*



## 22 GPM FUEL PUMP

### OWNER'S MANUAL



**WARNING:** Read carefully and understand all **INSTRUCTIONS** before operating. Failure to follow the safety rules and other basic safety precautions may result in serious personal injury.

**Item # 24925**

Thank you very much for choosing a Roughneck™ Product! For future reference, please complete the owner's record below:

Model: \_\_\_\_\_ Purchase Date: \_\_\_\_\_

Save the receipt, warranty and these instructions. It is important that you read the entire manual to become familiar with this product before you begin using it.

This machine is designed for certain applications only. The distributor cannot be responsible for issues arising from modification. We strongly recommend this machine is not modified and/or used for any application other than that for which it was designed. If you have any questions relative to a particular application, DO NOT use the machine until you have first contacted distributor to determine if it can or should be performed on the product.

For technical questions, please call **1-800-222-5381**.

## **INTRODUCTION**

**PUMP:** Electric self-priming rotary vane pump, equipped with by-pass valve and built-in filter

**MOTOR:** Asynchronous motor, single phase, 2-pole, closed type (Protection class IP55), self-ventilating

The pump is designed to run on 120V, 60HZ power and supply a flow rate of up to 22 GPM (80 LPM) with diesel or light oils.

## **TECHNICAL SPECIFICATIONS**

<b>Model</b>	24925
<b>Voltage</b>	120 Volts
<b>Frequency</b>	60 Hz
<b>Power</b>	450 Watts
<b>Flow Rate</b>	22 GPM
<b>Inlet/Outlet</b>	1in.

## **GENERAL SAFETY REGULATIONS**

 **WARNING:** Read carefully and understand all **INSTRUCTIONS** before operating. Failure to follow the safety rules and other basic safety precautions may result in serious personal injury. Save these instructions in a safe place and on hand so that they can be read when required. Keep these instructions to assist in future servicing.

 **WARNING:** The warnings, cautions, and instructions discussed in this instruction manual cannot cover all possible conditions or situations that could occur. It must be understood by the operator that common sense and caution are factors that cannot be built into this product, but must be supplied by the operator.

- 1. Keep the work area clean and dry.** Damp or wet work areas can result in injury.
- 2. Keep children away from work area.** Do not allow children to handle this product.
- 3. Store idle equipment.** When not in use, tools and equipment should be stored in a dry location to inhibit rust. Always lock up tools and equipment, and keep out of reach of children.

**4. Use the right tool for the job.** Do not attempt to force small equipment to do the work of larger industrial equipment. There are certain applications for which this equipment was designed. It will do the job better and more safely at the capacity for which it was intended. Do not modify this equipment, and do not use this equipment for a purpose for which it was not intended.

**5. Check for damaged parts.** Before using this product, carefully check that it will operate properly and perform its intended function. Check for damaged parts and any other conditions that may affect the operation of this product. Replace damaged or worn parts immediately.

**6. Do not overreach.** Keep proper footing and balance at all times to prevent tripping, falling, back injury, etc.

**7. DO NOT use the equipment when tired or under the influence of drugs, alcohol, or medication.** A moment of inattention while operating this equipment may result in serious personal injury.

**8. Industrial applications must follow OSHA requirements.**

## SPECIFIC OPERATION WARNINGS

	<b>⚠ DANGER</b>
	Electrical shock hazard. Electrical wiring should be done by a licensed electrician in compliance with local, state and national electrical code, ANSI/NFPA 70, 30, 30A as appropriate. Proper ground must be provided to avoid the possibility of electrical shock. Failure to comply with this warning could result in serious injury and/or loss of property.

**⚠ WARNING:** Improper use or installation of this product can cause serious bodily injury or death.

### **NOT FOR USE WITH LIQUIDS SUCH AS GASOLINE, ALCOHOL, EXPLOSIVES, CORROSIVES AND FLAMMABLE, ALIMENTARY LIQUIDS.**

Do not use the unit in an explosive environment.

Do not use the unit next to flammable liquids (gasoline, alcohol, etc.).

Do not use the unit in closed environments in the presence of gasoline, LPG or methane fuelled vehicles.

Always wear fuel-resistant gloves and clothes during diesel delivery and wash hands with water and soap at the end. Clean fuel spills at once to avoid slips and/or pollution.

Always wear suitable clothes and use suitable protective devices when cleaning, especially when removing dust or waste. Always use aspirators when cleaning fuel spills.

Never place hands or limbs under moving parts.

**⚠ WARNING:** To ensure safe and efficient operation, it is essential to read and follow each of these warnings and precautions.

1. DO NOT smoke near pump or use pump near an open flame. Fire could result.
2. Disconnect power to pump before servicing pump.

## OPERATING CONDITIONS

### 1. ENVIRONMENTAL CONDITIONS

---

**Temperature:** Min -4°F (-20°C)/ Max +140°F (+60°C)

**Relative Humidity:** Max. 90%

**⚠ WARNING:**

The temperature limits should be applied to the pump components and must be respected to avoid possible damage or malfunction.

## 2. ELECTRICAL POWER SUPPLY

The AC pump must be supplied by a single-phase alternating current line whose nominal values are shown in the table TECHNICAL SPECIFICATIONS above. The maximum acceptable variations from the electrical parameters are:

**Voltage:** ± 5% of the nominal value

**Frequency:** ± 2% of the nominal value

**⚠ WARNING:**

Power from lines with values outside the indicated limits can damage the electrical components.

**⚠ WARNING:**

DO NOT KEEP THE PUMP WORK IN BYPASS CONDITION MORE THAN 2 MINUTES.

## 3. FLUIDS PERMITTED/ FLUIDS NOT PERMITTED

### PERMITTED:

Diesel fuel or light oils at a viscosity of from 2 to 5 cST (at a temperature of 98.6°F/37°C)

Minimum Flash point (PM): 131°F / 55°C

NOT PERMITTED	RELATED DANGER
Gasoline (Petrol)	Fire - explosion
Inflammable liquids with PM < 131°F/55°C	Fire - explosion
Liquids with viscosity > 20 cST	Motor overload
Water	Oxidation of the pump
Liquid food products	Contamination
Corrosive Chemicals	Corrosion of the pump Injury to people
Solvents	Fire – explosion Damage to gasket seals

## INSTALLATION

### 1. PRELIMINARY INSPECTION

- Check that the machine has not suffered any damage during transport or storage.
- Clean the inlet and outlet openings, removing any dust or residual packing material.
- Make sure that the motor shaft turns freely.
- Check that the electrical specifications correspond to those shown on the identification plate.

### 2. POSITIONING THE PUMP

- The pump can be installed in any position (pump axis vertical or horizontal).
- Attach the pump using screws of adequate diameter for the attachment holes provided in the base of the

---

pump.

 **WARNING:**

Do not install pump where flammable vapors can be present.

### 3. CONNECTING THE HOSE

- Before connection, make sure that the hoses and the suction tank are free of dirt and thread residue that could damage the pump and its accessories.
- Before connecting the delivery hose, partially fill the pump body with diesel fuel to facilitate priming.

#### Suction Hose

- Minimum nominal recommended diameter: 1in.
- Nominal recommended pressure: 145 PSI / 10 bar
- Use a hose suitable for functioning under suction pressure.

#### Delivery Hose

- Minimum nominal recommended diameter: 3/4in.
- Nominal recommended pressure: 145 PSI / 10 bar

 **WARNING:**

1. It is the installer's responsibility to use tubing with adequate characteristics. Tubing unsuitable for use with diesel fuel can damage the pump, injure persons and cause pollution.
2. Use oil resistant pipe sealant or Teflon® Tape on all pipe threads.
3. Check all the connections before each use. Tighten them if necessary. Loosening of the connections (threaded connections, flanging, gasket seals) can cause serious ecological and safety problems.

### 4. CONSIDERATIONS REGARDING DELIVERY AND SUCTION LINES

#### DELIVERY

The improper application of the length of the tubing, the diameter of the tubing and the installed line accessories may create unexpected large back pressure which may cause the (partial) opening of the pump bypass and consequently reduce the flow rate.

To reduce system resistance, it is recommended to use shorter tubing and/or tubing with a 1in. diameter.

#### SUCTION

The pump will prime to a height of 6.5 feet (2 meters). On tanks with a suction height over 6.5 feet., a foot valve may be required on the bottom of the suction tube to hold the fluid in the tube. Do not install the pump with a height higher than 9.8 feet (3 meters), or the pump will lose its prime.

The pump can work with pressure at the inlet as high as 7 PSI (0.5 bar). At a higher level, bubbling (cavitation) can begin, with a consequent of loss of flow rate and increase of system noise.

Keep the suction filters clean. Once clogged, filters increase system resistance.

The tank must be vented, or the pump may not prime or may lose its prime due to a vacuum in the tank.

 **WARNING:** In the case that the suction tank is installed higher than the pump installation, it is recommended to install an anti-siphon valve to prevent accidental diesel fuel leaks. Care should be taken during the installation process in order to control the back pressure.

---

## **DAILY USE**

- If using flexible tubing, attach the end of the tubing to the tanks. In the absence of an appropriate slot, solidly grasp the delivery tube before beginning dispensing.
- Before starting the pump make sure that the delivery valve is closed (dispensing nozzle or line valve).
- Turn the ON/OFF switch to ON. The bypass valve allows functioning with the delivery closed for only brief periods.
- Open the delivery valve, solidly grasping the end of the tubing.
- Close the delivery valve to stop dispensing.
- When dispensing is finished, turn off the pump.

### **WARNING:**

1. Functioning with the delivery closed is only allowed for brief periods (2 minutes maximum). After use, make sure the pump is turned off.
2. Do not rest suction tubing on bottom of tank.

### **Lack of electric power**

A lack of electric power, with the consequent of accidental stopping of the pump, can be caused by:

- A safety device tripping
- A drop in line voltage

In either case, act as follows before servicing the pump:

- Close the delivery valve
- Attach the end of the delivery to the slot provided on the tank
- Turn the ON/OFF switch to the OFF position

## **MAINTENANCE**

The pumps are designed and constructed to require a minimum of maintenance.

- On a weekly basis, check that the tubing joints have not loosened, to avoid any leakage.
- On a monthly basis, check the pump body and keep it clean of any impurities.
- On a monthly basis, check and keep the pump filter clean and any other filters installed.
- On a monthly basis, check that the electric power supply cables are in good condition.
- Under normal working conditions the noise emission from all models does not exceed the value of 70 dB at a distance of 3 feet from the electric pump.

## **TROUBLE SHOOTING**

<b>Problem</b>	<b>Possible Cause</b>	<b>Corrective Action</b>
The motor is not turning	Lack of electric power	Check the electrical connections and the safety systems
	Rotor jams	Check for possible damage or obstruction of the rotating components.
	Motor problems	Contact service department
Low or no flow rate	Low level in the suction tank	Refill the tank
	Foot valve blocked	Clean and/or replace the valve
	Filter clogged	Clean the filter
	Excessive suction pressure	Lower the pump with respect to the level
	High loss of head in the circuit (working with the bypass open)	Use shorter tubing or of greater diameter
	Bypass valve blocked	Dismantle the valve, clean and/or replace it
	Air entering the pump or the suction tubing	Check the seals of the connections
	A narrowing in the suction tubing	Use tubing suitable for working under suction pressure
	Low rotation speed	Check the voltage at the pump. Adjust the voltage and/or use cables of greater cross-section
The suction tubing is resting on the bottom of the tank	Raise the tubing	
Increased pump noise	Cavitation occurring	Reduce suction pressure
	Irregular functioning of the bypass	Dispense until the air is purged from the circuit
	Air present in the diesel fuel	Verify the suction connections
Leakage from the pump body	Seal damaged	Check and replace the mechanical seal



## DIAGRAMS AND PARTS LIST

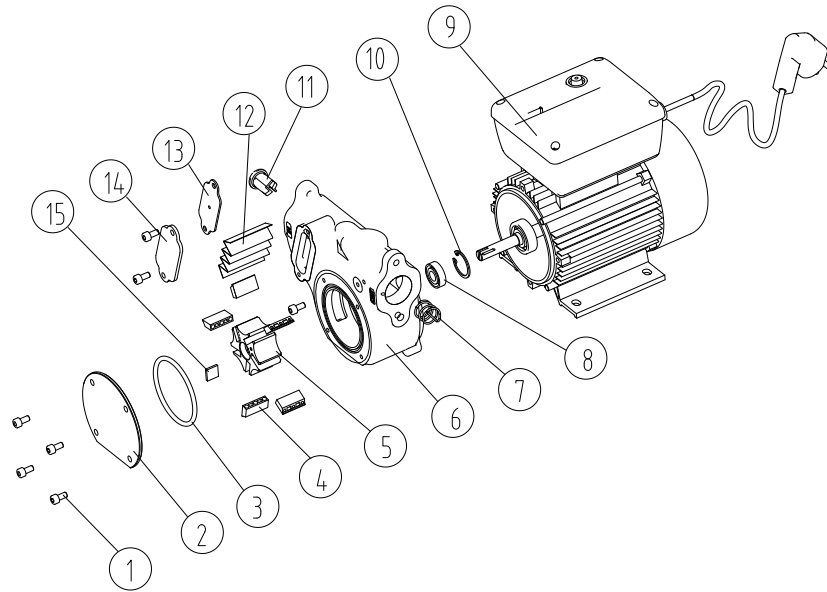

No.	Description	Quantity
1	SCREW M5×10	7
2	FRONT COVER	1
3	O-RING	1
4	BLADE	5
5	ROTOR	1
6	PUMP BODY	1
7	BY PASS SPRING	1
8	SEAL	1
9	MOTOR	1
10	SPRING COLLAR	1
11	BY PASS VALVE	1
12	FILTER	1
13	AIRPROOF RUBBER	1
14	FILTER COVER	1
15	KEY	1

For replacement parts and technical questions, please call **1-800-222-5381**.

---

## **WARRANTY**

One-year limited warranty



Distributed by  
Northern Tool + Equipment Co., Inc.  
Burnsville, MN 55306  
NorthernTool.com  
Made in China