



**WACKER  
NEUSON**

Ersatzteilkatalog  
Spare parts list  
Catalogo de piezas de repuesto  
Catalogue des pièces détachées

**Vibrationsplatte  
Vibratory plate  
Plancha vibratoria  
Plaque vibrante**

**AP1840e**



Type	AP1840e
Material Number	5100042939
Version	101
Language	de   en   es   fr



[www.wackerneuson.com](http://www.wackerneuson.com)

Copyright © 08.2020  
Wacker Neuson Produktion GmbH & Co. KG  
Printed in Germany.  
All rights reserved.

Ein Typenschild mit Typ, Artikelnummer, Version und Maschinen-Nummer ist an jedem Gerät angebracht. Die Daten von diesem Schild bitte notieren, damit sie auch bei Verlust oder Beschädigung des Schildes noch vorhanden sind. Der Typ, die Artikelnummer, die Versions-Nummer und die Maschinen-Nummer sind bei der Ersatzteilbestellung oder Nachfragen bezüglich Service-Informationen stets erforderlich.

Bei den in den Ersatzteillisten fettgedruckten Nummern handelt es sich um empfohlene Ersatzteile. Dies bedeutet, daß diese Teile bei normalen Anwendungsbedingungen natürlicher Abnutzung ausgesetzt sind und gelegentlich ersetzt oder überarbeitet werden müssen. Es wird geraten, diese Teile auf Lager bereit zu haben, um für Service-Arbeiten an diesem Gerät vorbereitet zu sein. Lagerbestände für diese und andere Teile, welche für ausgiebigere Reparaturarbeiten benötigt werden, können je nach Service-Gewohnheiten der einzelnen Kunden variieren.

Die Nummern meines Gerätes sind:

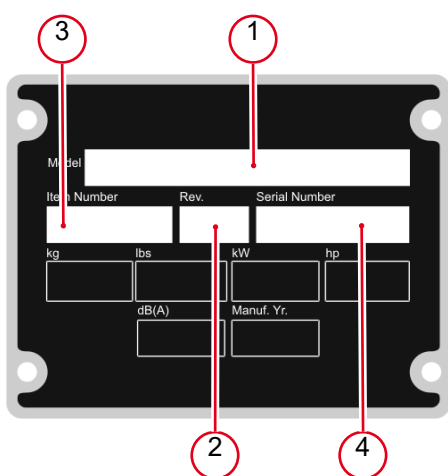

1. Typ
2. Version
3. Artikel-Nr.
4. Maschinen-Nr.

**Umrechnungstabelle**

Volumeneinheit	
1 ml	0.034 US fl.oz.
1 l	0.260 gal
Längeneinheit	
1 mm	0.039 in
1 m	3.280 ft
Gewicht	
1 kg	2.200 lbs
1 g	0.035 oz
Geschwindigkeit	
1 km/h	0.620 mph
Drehmoment	
1 Nm	0.740 ft.lbs

A nameplate listing the Model Number, Item Number, Revision, and Serial Number is attached to each unit. Please record the information found on this plate so it will be available should the nameplate become lost or damaged. When ordering parts or requesting service information, you will always be asked to specify the model, item number, revision number, and serial number of the unit.

Part Numbers appearing in boldface type are recommended spare parts. This means that these parts are subject to wear under normal operating conditions and may require periodic service or replacement. It is recommended that these items be stocked to meet the expected service requirements of this model. Actual stocking quantities of these and other parts used in more extensive repairs will depend on the service practices of each customer.

My machine's numbers are:



1. Model
2. Revision
3. Item No.
4. Serial No.

**Conversion table**

Volume unit	
1 ml	0.034 US fl.oz.
1 l	0.260 gal
Unit of length	
1 mm	0.039 in
1 m	3.280 ft
Weight	
1 kg	2.200 lbs
1 g	0.035 oz
Speed	
1 km/h	0.620 mph
Torque	
1 Nm	0.740 ft.lbs

Una placa de identificación con el modelo, número de referencia, nivel de revisión y número de serie ha sido añadida en cada máquina. Favor de anotar los datos en la placa en caso de que la placa de identificación sea destruida o perdida. En todos los pedidos para repuestos necesita siempre el modelo, el número de referencia, el nivel de revisión y el número de serie de la máquina en cuestión.

Los números de partes en negritas en las Listas Ilustradas de Partes son los repuestos recomendados, esto quiere decir que estas partes se desgastarán bajo circunstancias de funcionamiento normales y pueden requerir servicio periódico o su reemplazo. Se recomienda que el cliente mantenga un abastecimiento adecuado de estas partes para poder satisfacer la demanda requerida por el servicio a la máquina. La cantidad de repuestos que el cliente necesitará para reparaciones dependerá de la póliza de servicio de cada cliente.

Los números de mi máquina son:



1. Modelo
2. Nivel de revisión
3. Número de referencia
4. Número de Serie

**Tabla de conversión**

Unidad de volumen	
1 ml	0.034 US fl.oz.
1 l	0.260 gal
Unidad de longitud	
1 mm	0.039 in
1 m	3.280 ft
Peso	
1 kg	2.200 lbs
1 g	0.035 oz
Velocidad	
1 km/h	0.620 mph
Par de apriete	
1 Nm	0.740 ft.lbs



Une plaque signalétique mentionnant le modèle, le numéro de référence, le niveau de revision et le numéro de série est fixée sur chaque machine. Veuillez noter les informations relevées sur cette plaque de façon à ce qu'elles soient toujours disponibles si la plaque signalétique venait à être perdue ou endommagée. Lorsque vous commandez des pièces détachées ou vous sollicitez des informations après-vente, on vous demandera toujours de préciser le modèle, le numéro de référence, le niveau de revision et le numéro de série de la machine.

Les numéros de pièces imprimés en caractères gras dans les Listes des Pièces Détachées de ce manuel sont les pièces détachées recommandées par la Wacker. Cela veut dire que ces pièces sont sujettes à usure dans des conditions de travail normales et peuvent nécessiter de l'entretien ou leur remplacement. Nous recommandons que vous disposez d'un stock de ces pièces pour pouvoir satisfaire la demande d'entretien de cette machine. Le client doit décider lui-même de la quantité exacte de pièces de rechange qu'il disposera dans ses stocks.

Les numéros de ma machine son :



1. Typ
2. Version
3. Artikel-Nr.
4. Maschinen-Nr.

**Table de conversion**

Unité de volume	
1 ml	0.034 US fl.oz.
1 l	0.260 gal
Unité de longueur	
1 mm	0.039 in
1 m	3.280 ft
Poids	
1 kg	2.200 lbs
1 g	0.035 oz
Vitesse	
1 km/h	0.620 mph
Couple de serrage	
1 Nm	0.740 ft.lbs

Vibrationsplatte  
Vibration plate  
Plancha vibradora  
Plaque vibrante ..... 10

Vibrationsplatte  
Vibration plate  
Plancha vibradora  
Plaque vibrante ..... 12

Rahmen Kpl.  
Frame cpl.  
Chasis cpl.  
Châssis cpl. .... 14

Schalter  
Switch  
Interruptor  
Interrupteur ..... 16

Umformer Kpl.  
Converter cpl.  
Convertidor cpl.  
Convertisseur cpl. .... 18

Erreger Kpl.  
Exciter cpl.  
Excitador cpl.  
Excitateur cpl. .... 20

Bügel Kpl.  
Shackle cpl.  
Estribo cpl.  
Étrier cpl. .... 22

Aufkleber  
Labels  
Calcomanías  
Autocollants ..... 24

Zubehör  
Accessories  
Accesorios  
Accessoires

Fahrgestell Kpl.  
Trolley cpl.  
Dispositivo de transporte cpl.  
Chassis cpl. .... 26

Berieselungsanlage Kpl.  
Water system cpl.  
Sistema de rociado cpl.  
Système diffuseur cpl. .... 28

Gleitvorrichtung  
Urethane pad kit  
Placa de deslizamiento  
Jeu de tapis en polyuréthane ..... 30



Akku BP1000 Battery bp1000 Bateria bp1000 Accumalteur bp1000 .....	32
---	----

Ladegerät Battery charger Cargador par batería Chargeur de batteries .....	34
---	----

Ladegerät Battery charger Cargador par batería Chargeur de batteries .....	36
---	----

Ladegerät C 48/13 US Battery charger c 48/13 us Cargador par batería c 48/13 us Chargeur de batteries .....	40
--	----

Transportkiste Handling case Caja de transporte Caisse de transport .....	44
--	----





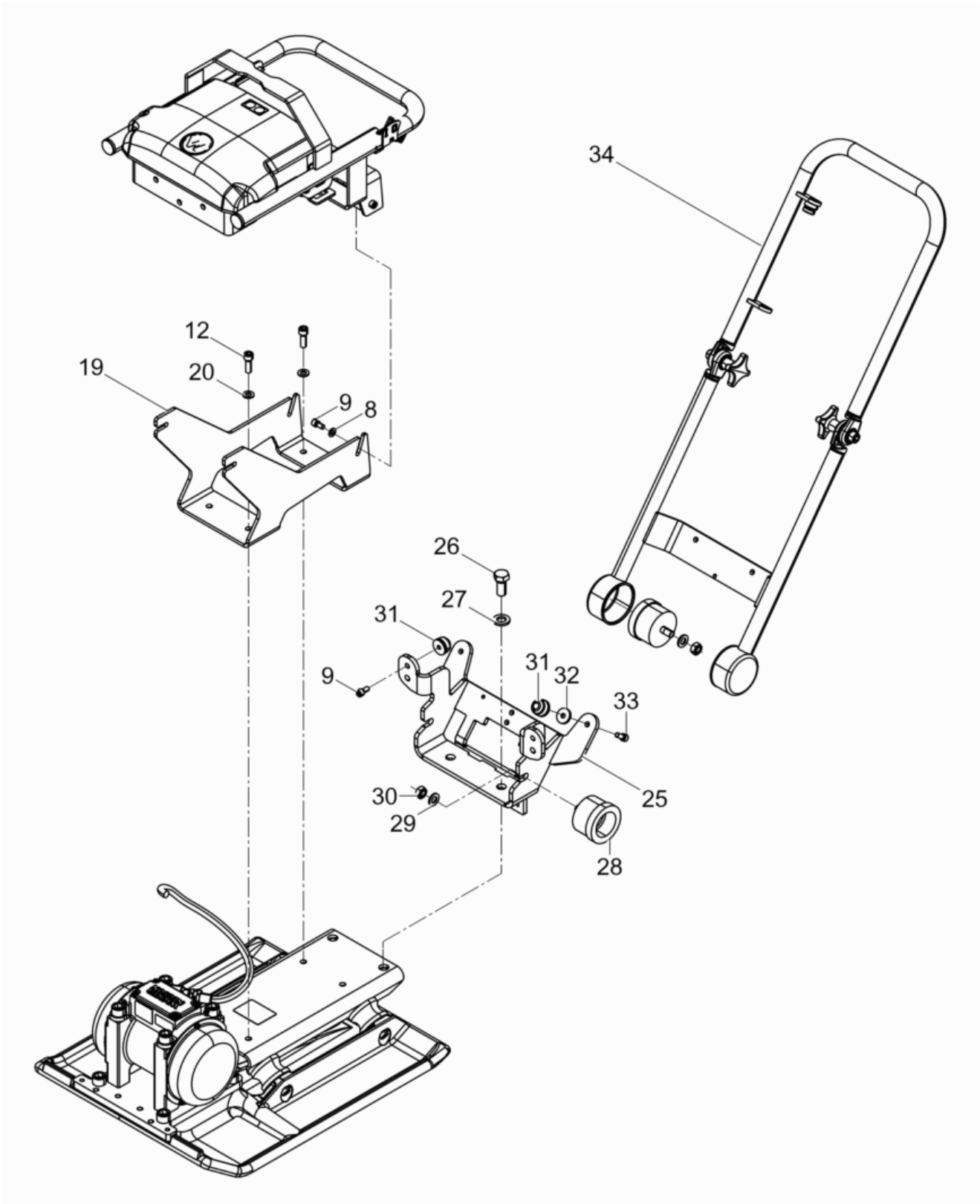

Pos. Ref.	Artikel Nr. Part No.	Qty.	Unit	Beschreibung Description	Description Description	Abm. Measur.	Norm Standard
						Drehm. Torque	Schmierstoff Sealant
2	5100038300	1	pc	Blech Chapa	Plate Tôle		
3	5000011580	4	pc	Zylinderschraube Tornillo cilíndrico	Cheese head screw Vis à tête cylindrique	M16 x 30 210Nm/155ft.lbs	ISO4762
8	5000010622	4	pc	Scheibe Arandela	Flat washer Rondelle		
9	5000011544	6	pc	Zylinderschraube Tornillo cilíndrico	Cheese head screw Vis à tête cylindrique	M8 x 16 25Nm/18ft.lbs	ISO4762
12	5000011534	4	pc	Zylinderschraube Tornillo cilíndrico	Cheese head screw Vis à tête cylindrique	M10 x 30 49Nm/36ft.lbs	ISO4762
19	5100040341	1	pc	Blech Chapa	Plate Tôle		
20	5000010621	4	pc	Scheibe Arandela	Washer Rondelle		
25	5000201824	1	pc	Deichselkonsole Consola de barra de mando	Center pole console Console de timon		
26	5000011522	2	pc	Sechskantschraube Tornillo hexagonal	Hexagonal head cap screw Vis à tête hexagonale	M16 x 35 210Nm/155ft.lbs	DIN933
27	5000021988	2	pc	Sicherungsscheibe Arandela de seguridad	Lock washer Rondelle d'arrêt	HS16	
28	5000106557	2	pc	Gummi-Metall-Puffer Tope caucho-metal	Shockmount Tampon métallique oscillant		
29	5000010620	2	pc	Scheibe Arandela	Flat washer Rondelle	12	ISO7090
30	5000010884	2	pc	Sechskantmutter Tuerca hexagonal	Hexagon nut Écrou hexagonal	M12	DIN934
31	5000105056	4	pc	Anschlagpuffer Amortiguador	Shockmount Silentbloc	M30 x 20	
32	5000031632	2	pc	Scheibe Arandela	Washer Rondelle		
33	5000011543	2	pc	Zylinderschraube Tornillo hueco	Socket head screw Vis à six-pans creux	M8 x 20 24Nm/18ft.lbs	ISO4762
34	5000108269	1	pc	Bügel Kpl. Estribo cpl.	Shackle cpl. Étrier cpl.		

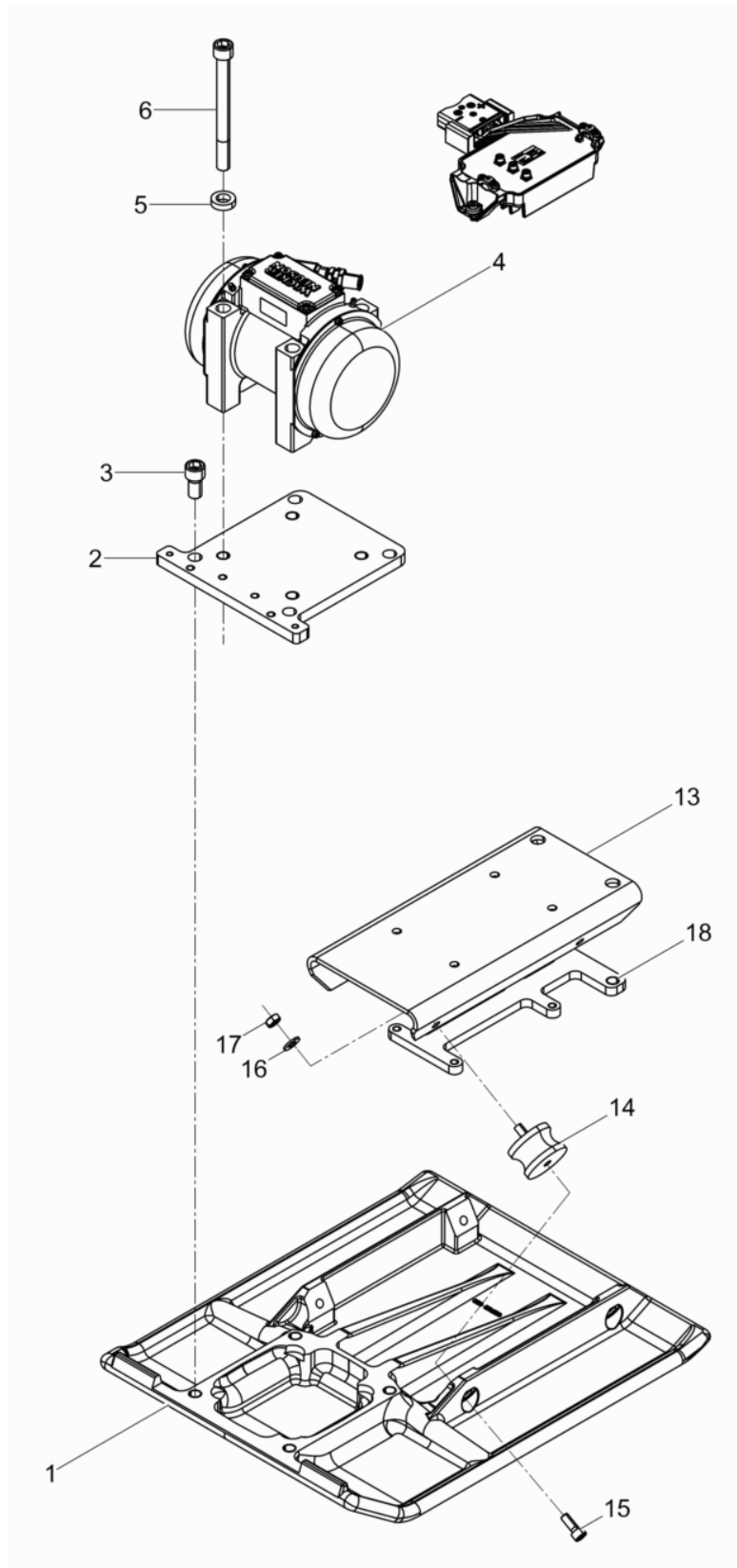

Pos. Ref.	Artikel Nr. Part No.	Qty.	Unit	Beschreibung Description	Description Description	Abm. Measur.	Norm Standard
						Drehm. Torque	Schmierstoff Sealant
1	5100039342	1	pc	Grundplatte Placa base	Base plate Plaque de base		
2	5100038300	1	pc	Blech Chapa	Plate Tôle		
3	5000011580	4	pc	Zylinderschraube Tornillo cilíndrico	Cheese head screw Vis à tête cylindrique	M16 x 30 210Nm/155ft.lbs	ISO4762
4	5100050471	1	pc	Erreger Kpl. Excitador cpl.	Exciter cpl. Excitateur cpl.		
5	5000095182	4	pc	Scheibe Arandela	Washer Rondelle	B18	DIN7989
6	5000095457	4	pc	Zylinderschraube Tornillo cilíndrico	Cheese head screw Vis à tête cylindrique	M16 x 170 210Nm/155ft.lbs	ISO4762
13	5100038301	1	pc	Blech Chapa	Plate Tôle		
14	5000037378	4	pc	Gummi-Metall-Kerbpuffer Tope caucho-metal	Shockmount Tampon métallique oscillant	60 x 40	
15	5000011535	4	pc	Zylinderschraube Tornillo cilíndrico	Cheese head screw Vis à tête cylindrique		
16	5000033988	4	pc	Spannscheibe Arandela elástica	Lockwasher Rondelle de ressort	10	DIN6796
17	5000010883	4	pc	Sechskantmutter Tuerca hexagonal	Hexagon nut Écrou hexagonal		
18	5100038312	1	pc	Blech Chapa	Plate Tôle		

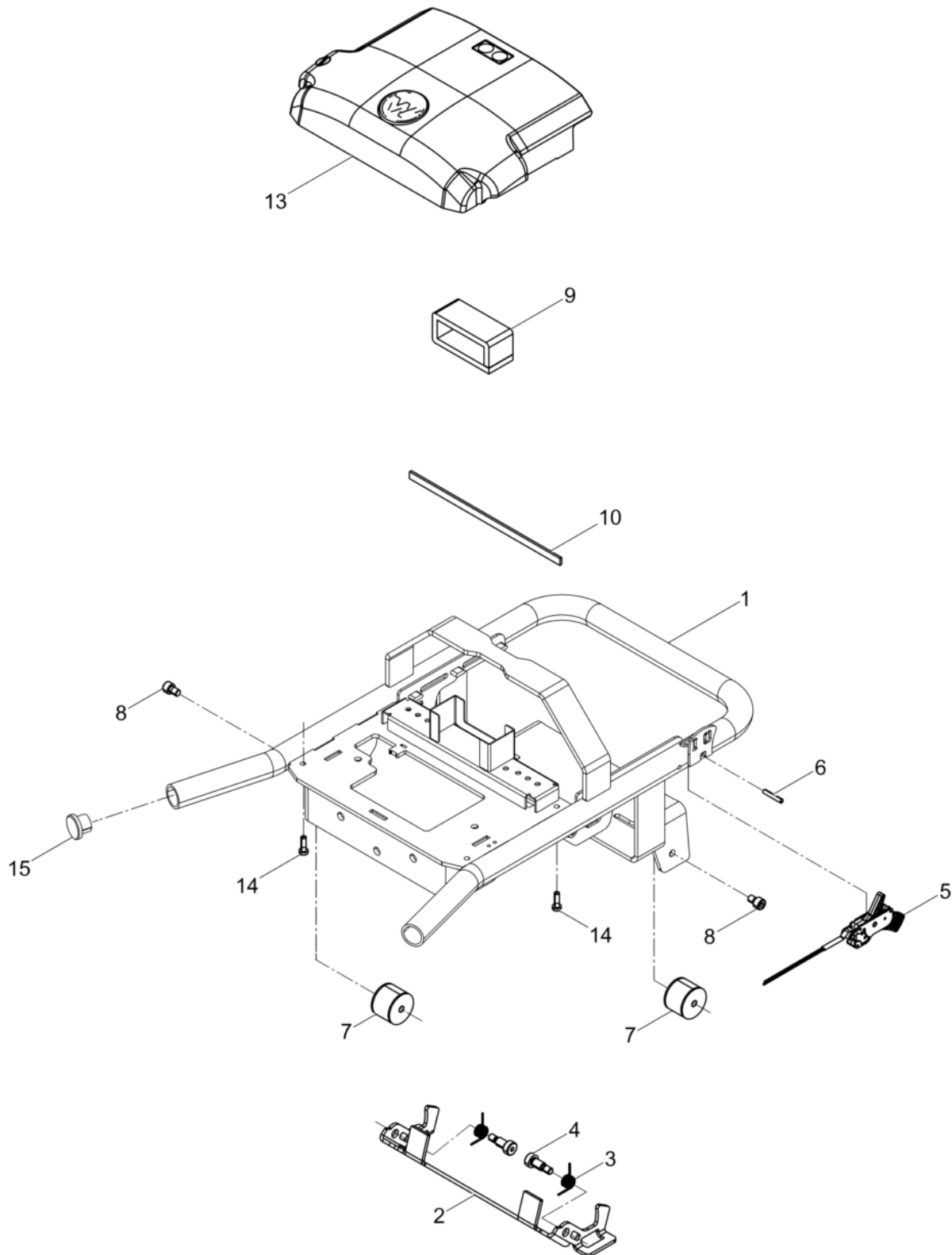

Pos. Ref.	Artikel Nr. Part No.	Qty.	Unit	Beschreibung Description	Description Description	Abm. Measur.	Norm Standard
						Drehm. Torque	Schmierstoff Sealant
1	5100038308	1	pc	Bügel Estribo	Shackle Étrier		
2	5100025574	1	pc	Sicherungsblech Chapa de seguridad	Locking plate Tôle de sûreté		
3	5100025600	2	pc	Schenkelfeder Resorte de brazo	Leg spring Ressort coude		
4	5100005556	2	pc	Passschraube Tornillo de ajuste	Shim screw Vis dajustage	10x16	
5	5100002571	1	pc	Schalter Interruptor	Switch Interrupteur		
6	5100009734	2	pc	Passkerbstift Pasador demiestriado	Grooved pin Tenon à encoche	5x30	
7	5000129818	4	pc	Gummi-Metall-Puffer Tope caucho-metal	Shockmount Tampon métallique oscillant		
8	5000013574	4	pc	Zylinderschraube Tornillo cilíndrico	Cheese head screw Vis à tête cylindrique		
9	5100002878	1	pc	Schaumstoffeinsatz Materia espumoso	Foam Mousse		
10	5100002886	1	pc	Dichtband Lang Cinta de sello larga	Sealing tape long Ruban isolant long		
13	5100001723	1	pc	Schutzhaube Kpl. Cubierta protectora cpl.	Protective hood cpl. Capot de protection cpl.		
14	5000222605	4	pc	Linsenkopfschraube Tornillo gota de seboatado	Oval head screw Vis noyée lentiforme	M 6 x 20	
15	5100038315	2	pc	Lammelenstopfen Tapón	Plug Bouchon		

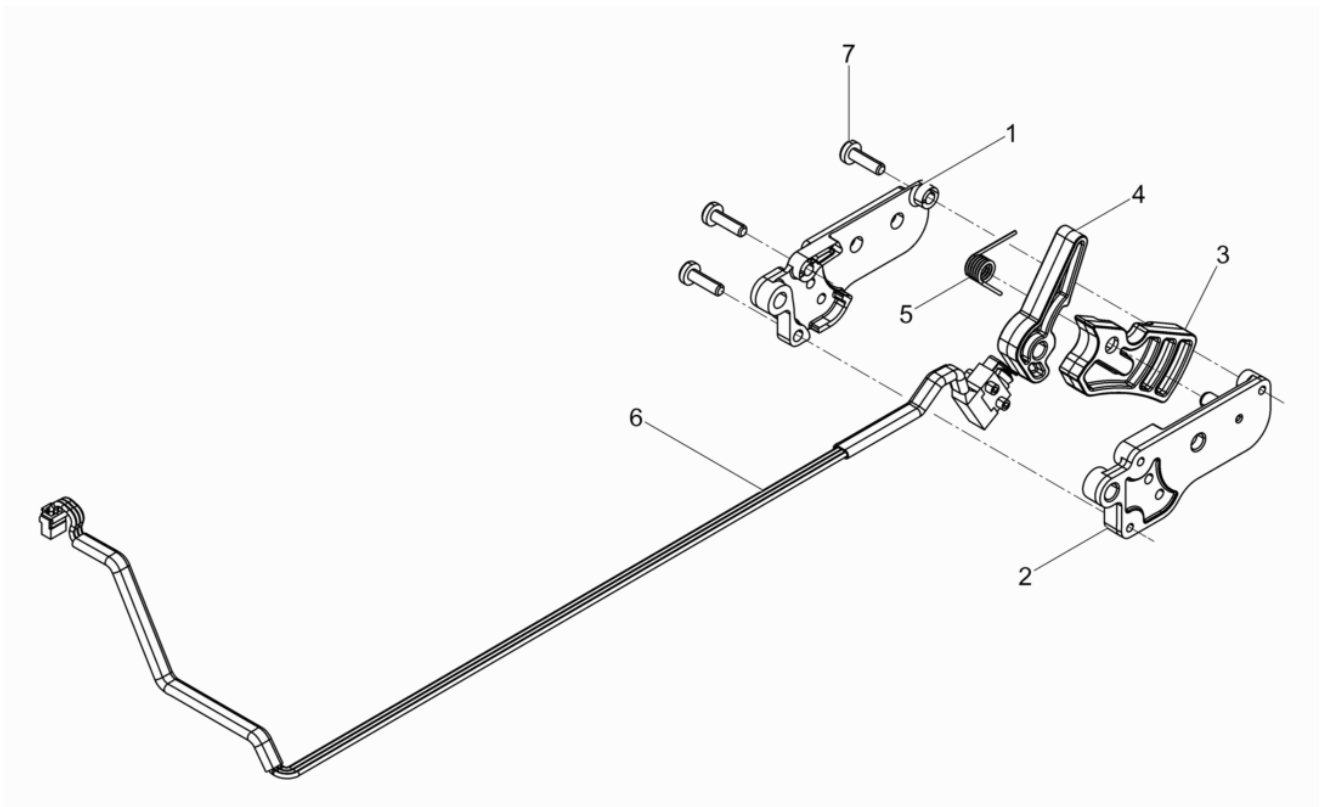



Pos. Ref.	Artikel Nr. Part No.	Qty.	Unit	Beschreibung Descripción	Description Description	Abm. Measur.	Norm Standard
						Drehm. Torque	Schmierstoff Sealant
1	5100001729	1	pc	Gehäusehälfte Rechts Semi-carcasa derecha	Housing half right Demi manivelle droite		
2	5100001731	1	pc	Gehäusehälfte Links Semi-carcasa izquierda	Housing half left Demi manivelle gauche		
3	5100001735	1	pc	Sicherung Retén	Retainer Dispositif de retenue		
4	5100001737	1	pc	Schalthebel Palanca de cambios	Shift lever Lever de change		
5	5100003006	1	pc	Schenkelfeder Resorte de brazo	Leg spring Ressort coude		
6	5100004436	1	pc	Schalter Kpl. Interruptor cpl.	Switch cpl. Interrupteur cpl.		
7	5100009739	3	pc	Linsenkopfschraube Tornillo gota de sebo	Oval head screw Vis noyée lentiforme	3,5x12	

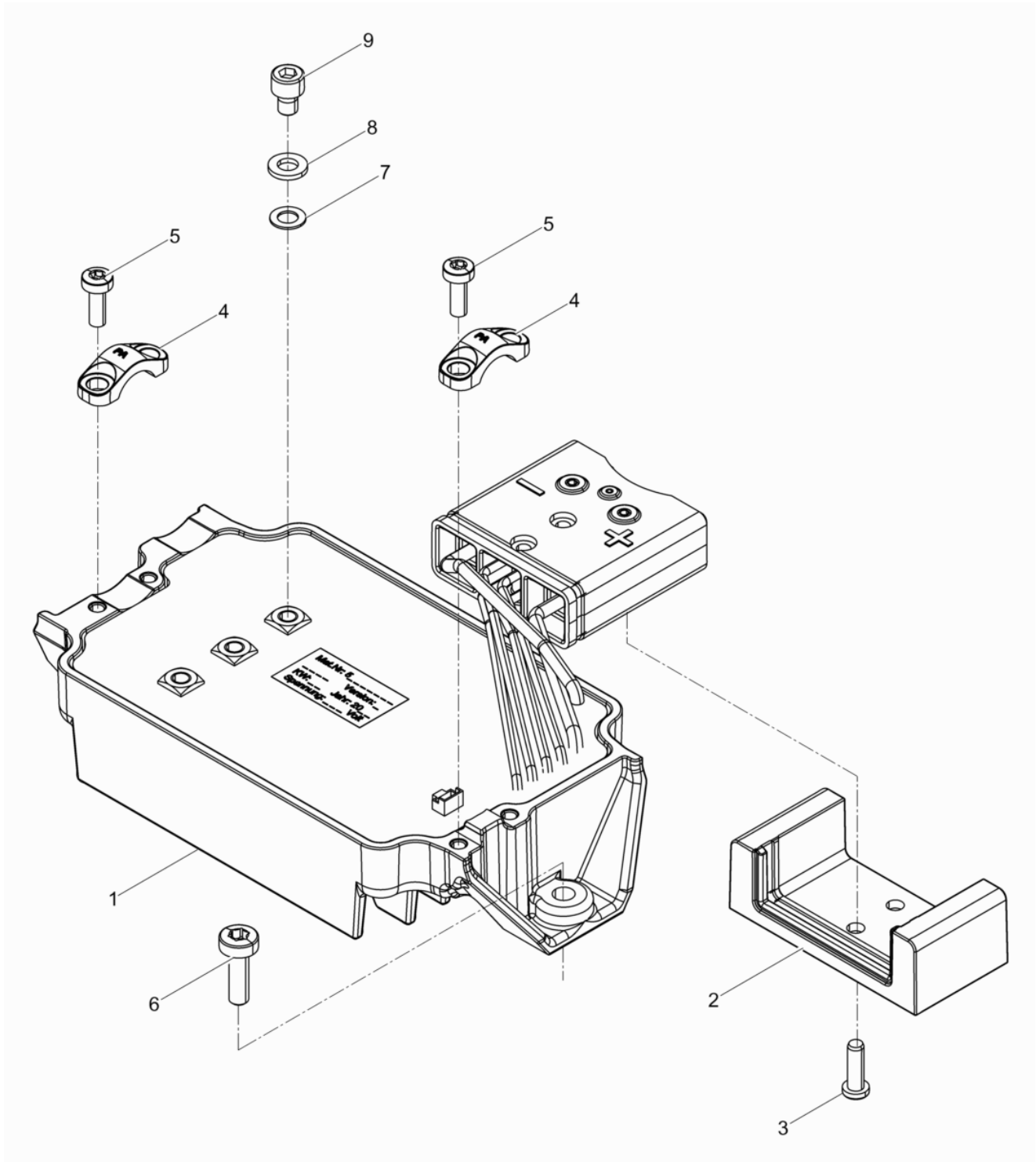

Pos. Ref.	Artikel Nr. Part No.	Qty.	Unit	Beschreibung Description	Description Description	Abm. Measur.	Norm Standard
						Drehm. Torque	Schmierstoff Sealant
1	5100042449	1	pc	Umformer AP Convertidor ap	Converter ap Convertisseur ap		
2	5100025637	1	pc	Halterung Soporte	Bracket Équerre		
3	5100010127	2	pc	Linsenkopfschraube Tornillo gota de sebo	Oval head screw Vis noyée lentiforme	5x16	
4	5100000179	2	pc	Schelle Abrazadera	Clamp Agrafe		
5	5000222073	4	pc	Schraube Tornillo	Screw Vis	M5x14	
6	5000108372	2	pc	Flachkopfschraube Tornillo de cabeza plana	Pan head screw Vis lentiforme	M6 x 20	ISO7045
7	5000202098	3	pc	Zahnscheibe Arandela dentada	Toothed lock washer Rondelle à dents	A 6,4	
8	5000010624	3	pc	Scheibe Arandela	Flat washer Rondelle		
9	5000014425	3	pc	Zylinderschraube Tornillo cilíndrico	Cheese head screw Vis à tête cylindrique	10Nm/7ft.lbs	

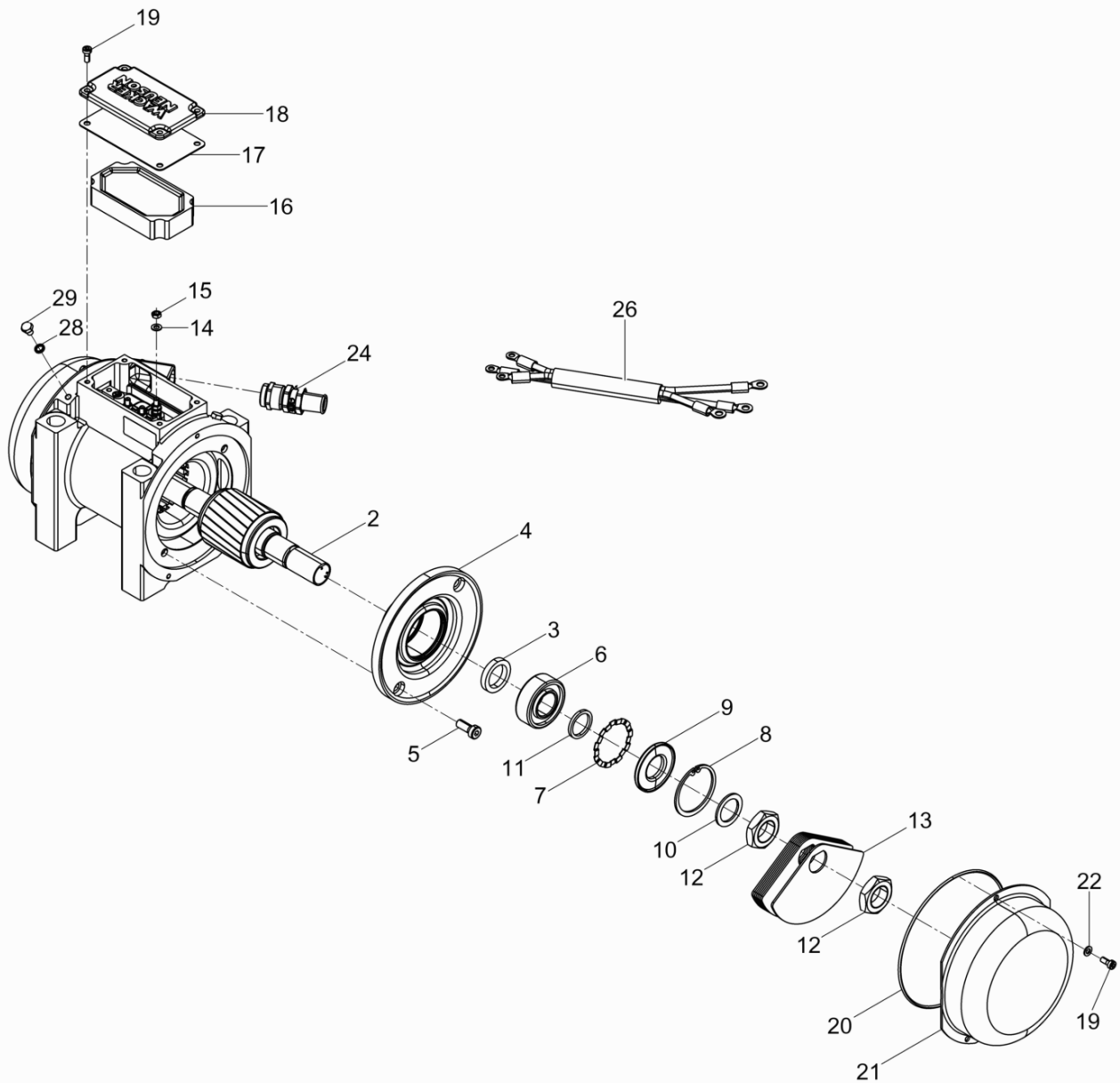

Pos. Ref.	Artikel Nr. Part No.	Qty.	Unit	Beschreibung Descripción	Description Description	Abm. Measur.	Norm Standard
						Drehm. Torque	Schmierstoff Sealant
2	5000068065	1	pc	Motorläufer Inducido del motor	Motor armature Rotor		
3	5000067915	2	pc	Zwischenring Anillo distanciador	Intermediary ring Bague intermédiaire		
4	5100049990	2	pc	Lagerschild Placa de cojinete	Bearing bracket Bride palier		
5	5000218693	4	pc	Zylinderschraube Tornillo cilíndrico	Cheese head screw Vis à tête cylindrique	M 8x20 25Nm/18ft.lbs	DIN7984
6	5000065842	2	pc	Zylinderrollenlager Rodamiento cilíndricos	Cylindrical roller bearing Roulement à rouleaux		
7	5000069297	2	pc	Abstandsscheibe Arandela distanciador	Distance washer Rondelle intermédiaire		
8	5002001047	2	pc	Sicherungsring Anillo de retención	Retaining ring Bague d'arrêt	52 x 2	DIN472
9	5000069296	2	pc	Dichtungslamelle (Satz) Laminilla de estanqueidad (juego)	Sealing lamina (set) Disque d'étanchéité (jeu)		
10	5000095890	2	pc	Ring Anillo	Ring Bague		
11	5002004794	2	pc	Stützscheibe Arandela de soporte	Supporting washer Disque d'appui	S25 x 35	DIN988
12	5000010820	4	pc	Sechskantmutter Tuerca hexagonal	Hexagon nut Écrou hexagonal	M24 x 1,5	DIN936
13	5000034236	16	pc	Unwucht Masa excéntrica	Eccentric weight Balourd	2,0	
14	5000012643	3	pc	Scheibe Arandela	Flat washer Rondelle	5 25Nm/18ft.lbs	ISO7090
15	5000012997	3	pc	Sechskantmutter Tuerca hexagonal	Hexagon nut Écrou hexagonal	M5	ISO4032
16	5000069291	1	pc	Gummiformteil Aisladora de goma	Rubber isolator Isolateur en caoutchouc		
17	5000068755	1	pc	Dichtung Junta	Seal Joint		
18	5000067945	1	pc	Deckel Tapa	Cover Couvercle		
19	5000095509	10	pc	Zylinderschraube Tornillo cilíndrico	Cheese head screw Vis à tête cylindrique	M5 x 12 10Nm/7ft.lbs	DIN6912
20	5000069617	2	pc	O-Ring Anillo-o	O-ring Bague-o		
21	5000219023	2	pc	Haube Kpl. Cubierta cpl.	Bonnet cpl. Capot cpl.		
22	5000010625	6	pc	Scheibe Arandela	Washer Rondelle		
24	5000038054	1	pc	Verschraubung Kpl. Atornilladura cpl.	Screw connection cpl. Raccord vis cpl.		
26	5100039275	1	pc	Zuleitungskabel Cable de alimentación	Power supply cable Câble damenée		
28	5000021670	2	pc	Usit-Ring Anillo-usit	Usit-ring Bague-usit	6,7 x 10 x 1	
29	5000013550	2	pc	Sechskantschraube Tornillo hexagonal	Hexagonal head cap screw Vis à tête hexagonale	M6 x 8 10Nm/7ft.lbs	ISO4017

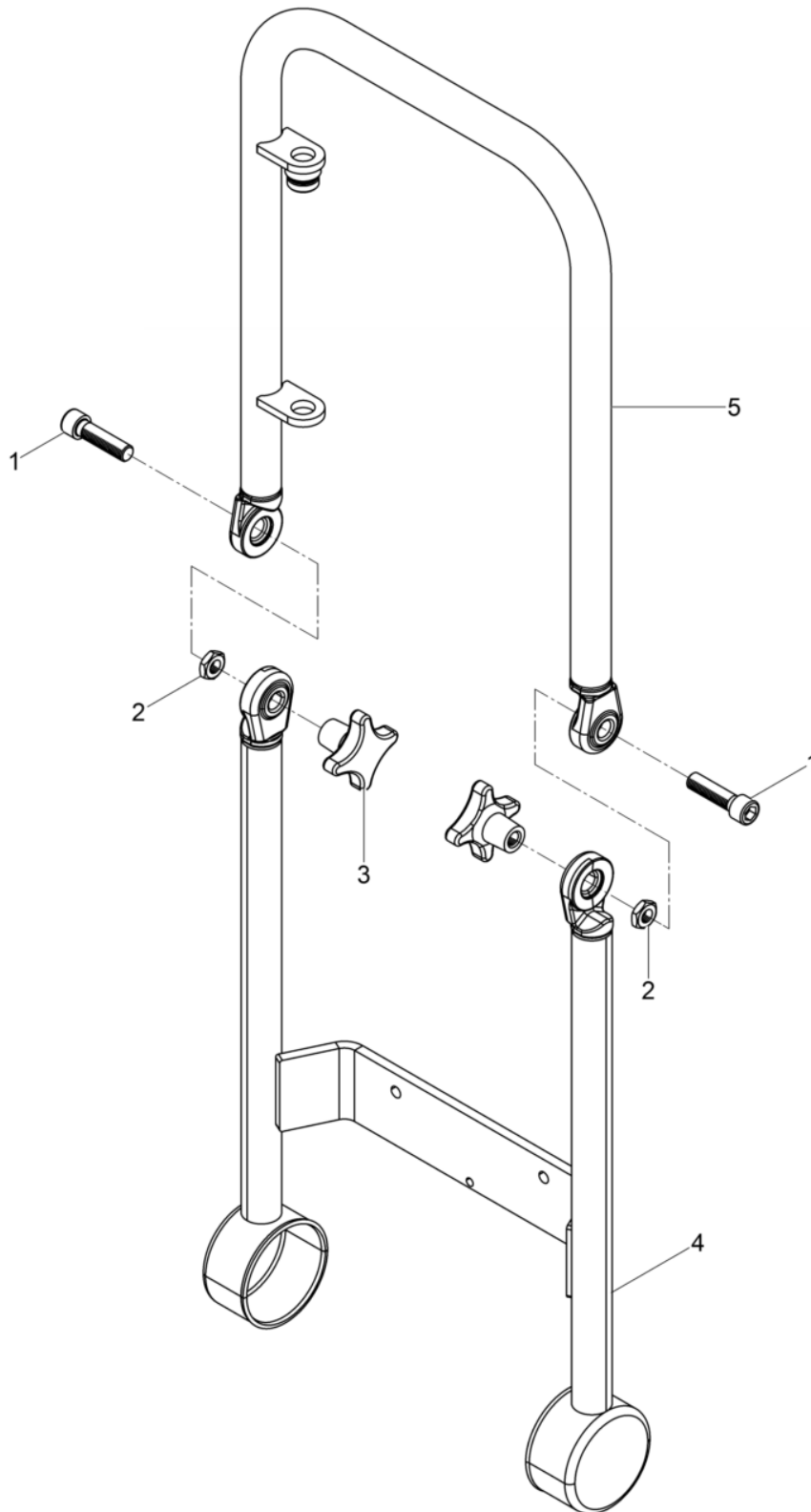

Pos. Ref.	Artikel Nr. Part No.	Qty.	Unit	Beschreibung Descripcion	Description Description	Abm. Measuram.	Norm Standard
						Drehm. Torque	Schmierstoff Sealant
1	5000011526	2	pc	Zylinderschraube Tornillo cilíndrico	Cheese head screw Vis à tête cylindrique	M12 x 45 86Nm/63ft.lbs	ISO4762
2	5000033349	2	pc	Sechskantmutter Tuerca hexagonal	Hexagon nut Écrou hexagonal	M12	DIN439
3	5000097454	2	pc	Kreuzgriff Empuñadura	Star-handle Poignée étoile		
4	5000108267	1	pc	Bügel Unten Estribo	Shackle Étrier		
5	5000108268	1	pc	Bügel Oben Estribo	Shackle Étrier		

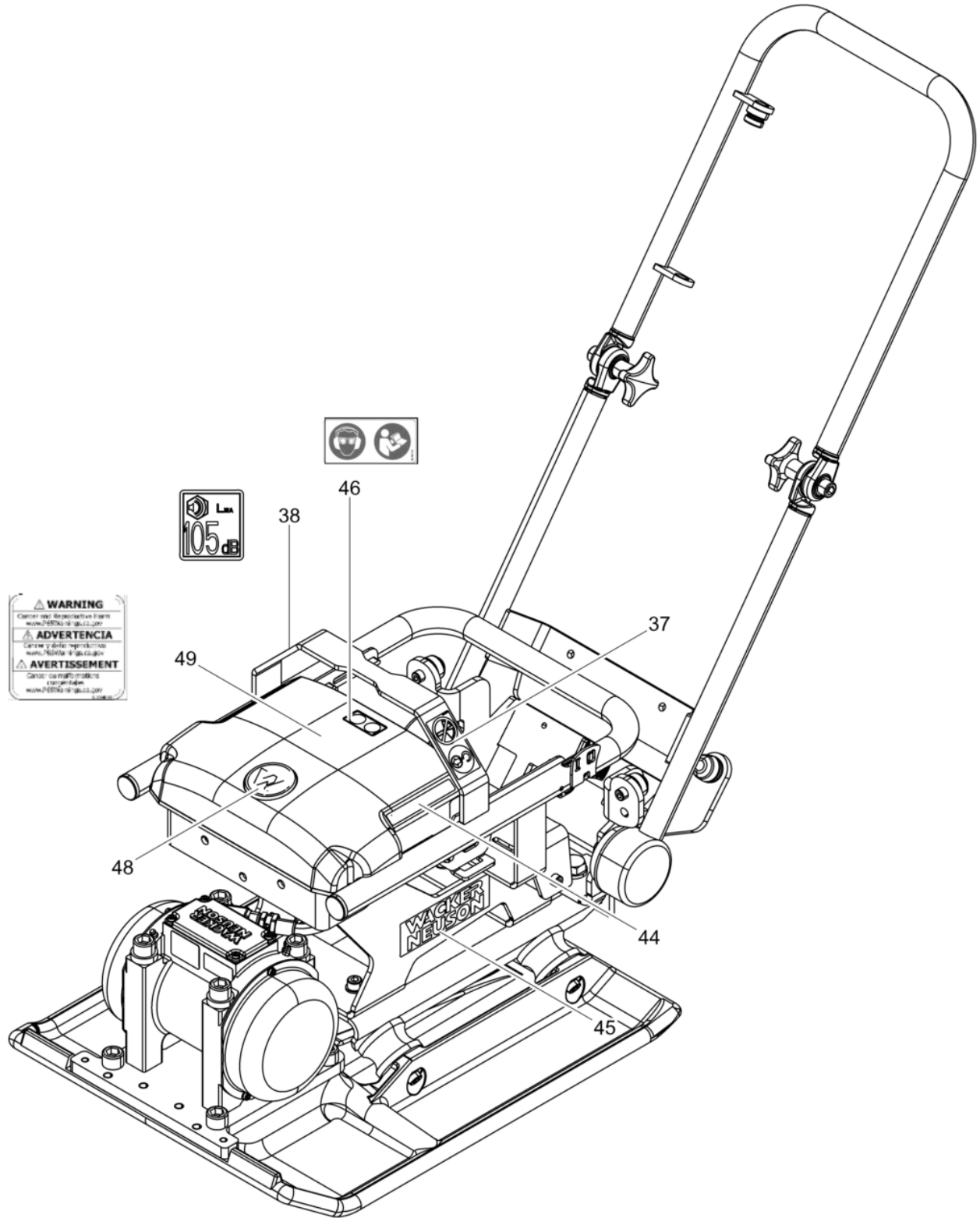



Pos. Ref.	Artikel Nr. Part No.	Qty.	Unit	Beschreibung Descripción	Description Description	Abm. Measur.	Norm Standard
						Drehm. Torque	Schmierstoff Sealant
37	5000219260	1	pc	Aufkleber Calcomanías	Labels Autocollants		
38	5000208195	1	pc	Aufkleber-Schalleistungspegel Etiqueta autoadhesiva-nivel de potencia acúëstica	Decal-sound power level Autocollante-niveau sonore		
44	5100044258	2	pc	Aufkleber Typ Tipo etiqueta autoadhesiva	Type label Autocollant de type		
45	5000213181	2	pc	Aufkleber Logo Calcomania insigniaipo	Label logo Autocollant logo	40mm	
46	5000219174	1	pc	Aufkleber Calcomanías	Labels Autocollants		
48	5100052440	1	pc	Aufkleber Symbol Calcomania símbolo	Label symbol Autocollant symbole		
49	5100045462	1	pc	Aufkleber Calcomania	Label Autocollant		

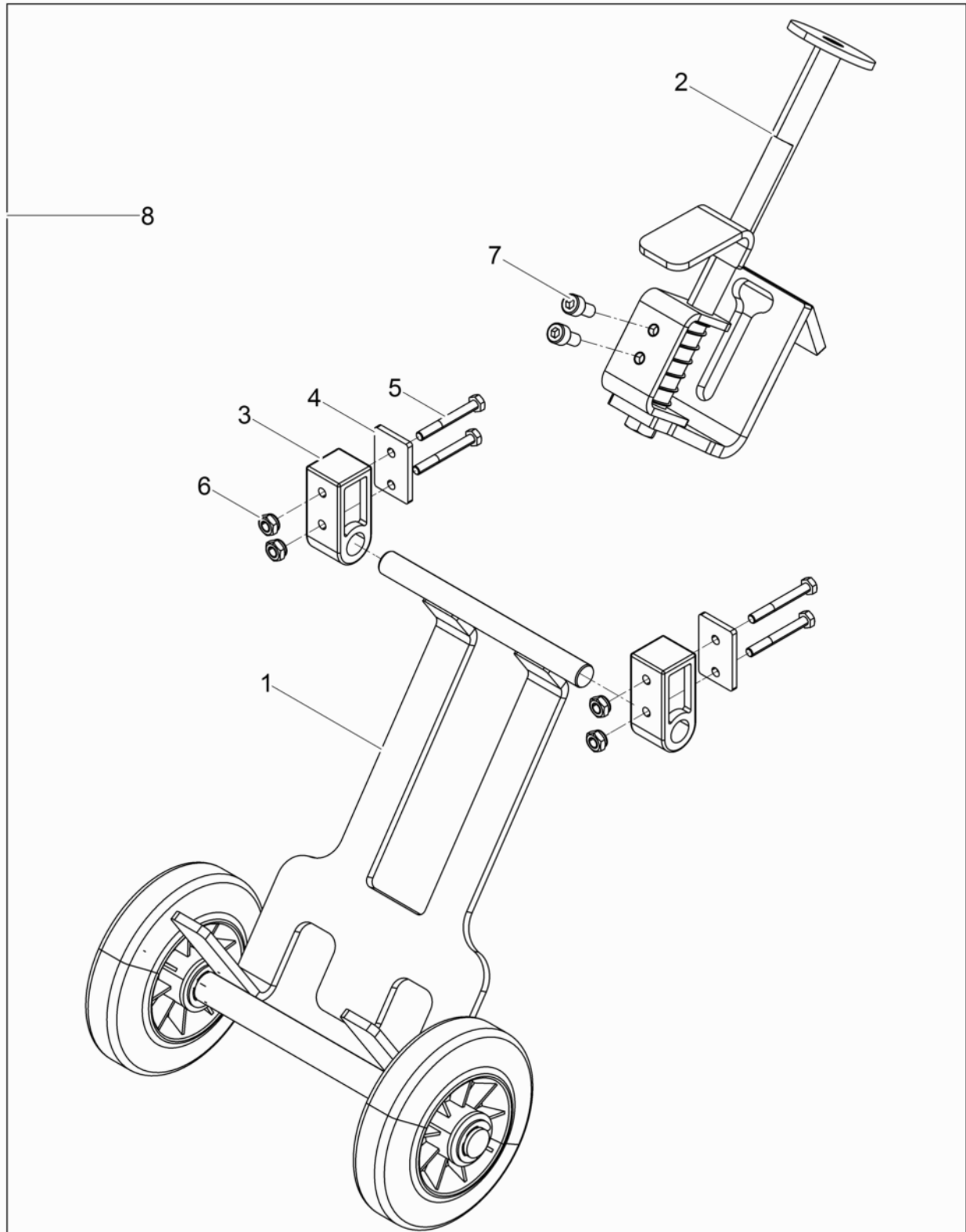

Pos. Ref.	Artikel Nr. Part No.	Qty.	Unit	Beschreibung Descripcion	Description Description	Abm. Measur.	Norm Standard
						Drehm. Torque	Schmierstoff Sealant
1	5000108248	1	pc	Fahrgestell Dispositivo de transporte	Trolley Chassis		
2	5000108249	1	pc	Arretierung Kpl. Dispositivo de retención cpl.	Lock cpl. Dispositif d'arrêt cpl.		
3	5000108286	2	pc	Halterung Soporte	Fixing device Bague de retenue		
4	5000108256	2	pc	Leiste Listón	Bar Listeau		
5	5000011331	4	pc	Sechskantschraube Tornillo hexagonal	Hexagonal head cap screw Vis à tête hexagonale	M6 x 50 10Nm/7ft.lbs	DIN931
6	5000010368	5	pc	Sechskantmutter Tuerca hexagonal	Hexagon nut Écrou hexagonal	M6	DIN985
7	5000011544	2	pc	Zylinderschraube Tornillo cilíndrico	Cheese head screw Vis à tête cylindrique	M8 x 16 25Nm/18ft.lbs	ISO4762
8	5000201979	1	pc	Fahrgestell Kpl. Dispositivo de transporte cpl.	Trolley cpl. Chassis cpl.		

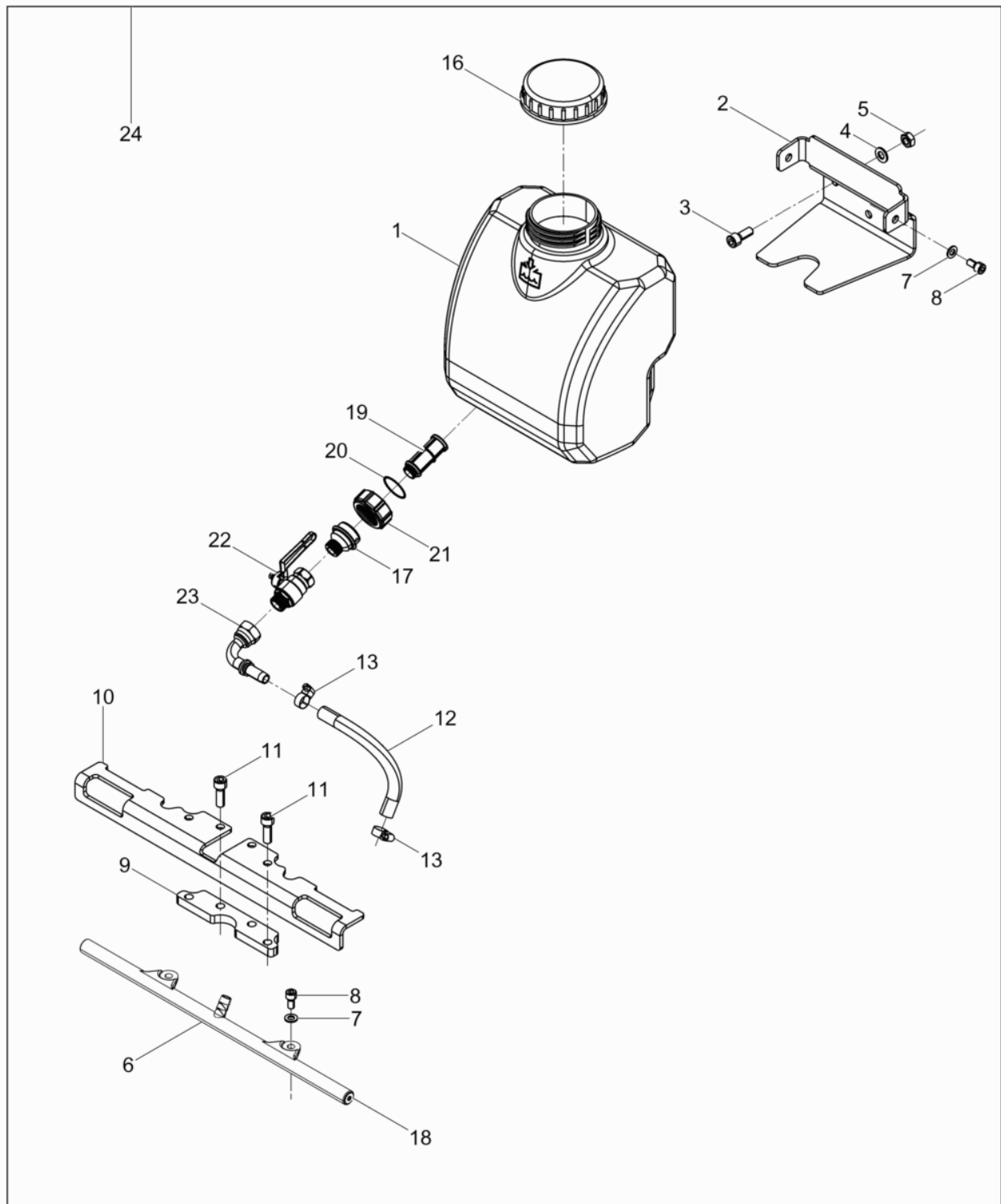

Pos. Ref.	Artikel Nr. Part No.	Qty.	Unit	Beschreibung Descripcion	Description Description	Abm. Measuram.	Norm Standard
						Drehm. Torque	Schmierstoff Sealant
1	5100028898	1	pc	Wassertank Tanque de agua	Watertank Reservoir à eau		
2	5100040447	1	pc	Blech Chapa	Plate Tôle		
3	5000011535	3	pc	Zylinderschraube Tornillo cilíndrico	Cheese head screw Vis à tête cylindrique		
4	5000010621	3	pc	Scheibe Arandela	Washer Rondelle		
5	5000010883	3	pc	Sechskantmutter Tuerca hexagonal	Hexagon nut Écrou hexagonal		
6	5100030809	1	pc	Berieselung Kpl. Systema de riego cpl.	Spinkler system cpl. Installation d'arrosage cpl.		
7	5000010622	4	pc	Scheibe Arandela	Flat washer Rondelle		
8	5000011544	4	pc	Zylinderschraube Tornillo cilíndrico	Cheese head screw Vis à tête cylindrique	M8 x 16 25Nm/18ft.lbs	ISO4762
9	5100038313	1	pc	Leiste Listón	Bar Listeau		
10	5100039343	1	pc	Schutzleiste Listón	Bar Listeau		
11	5000011534	4	pc	Zylinderschraube Tornillo cilíndrico	Cheese head screw Vis à tête cylindrique	M10 x 30 49Nm/36ft.lbs	ISO4762
12	5100028892	1	pc	Wasserschlauch Manguera de agua	Water hose Tuyau d'eau		
13	5000016837	2	pc	Schneckenengewindeschelle Abrazadera	Clamp Agrafe	12-20	
16	5000068351	1	pc	Schraubdeckel Tapa roscable	Screwed cover Couvercle fileté		
17	5100028921	1	pc	Flansch Brida	Flange Bride		
18	5100029615	2	pc	Einschraubstopfen Tapón	Plug Bouchon		
19	5100028890	1	pc	Wasserfilter Filtro de agua	Water filter Filtre		
20	5100028892	1	pc	Wasserschlauch Manguera de agua	Water hose Tuyau d'eau		
21	5100028920	1	pc	Überwurfmutter Tuerca de racor	Cap screw Écrou d'accouplement		
22	5100028889	1	pc	Kugelhahn Llave esférica	Ball valve Robinet à boisseau sqherique		
23	5100028897	1	pc	Pressnippel Conector	Connector Connexion		
24	5100044263	1	pc	Berieselung Kpl. Systema de riego cpl.	Spinkler system cpl. Installation d'arrosage cpl.		

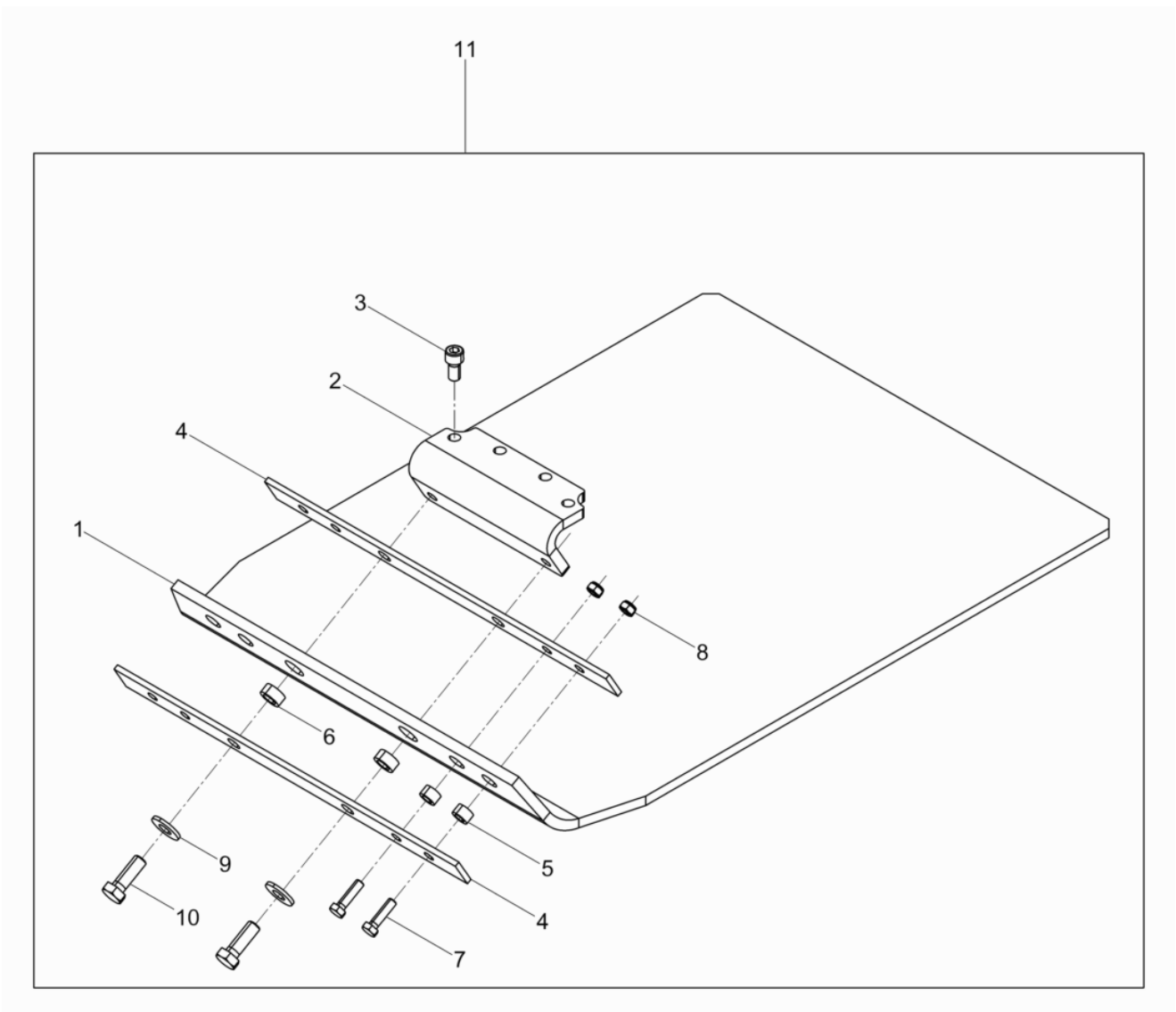

Pos. Ref.	Artikel Nr. Part No.	Qty.	Unit	Beschreibung Descripción	Description Description	Abm. Measur.	Norm Standard
						Drehm. Torque	Schmierstoff Sealant
1	5000047585	1	pc	Kunststoffplatte Juego de lamina de uretano	Urethane plate Dispositif de glissement		
2	5100041893	1	pc	Winkel Ángulo	Angle Coude		
3	5000011536	4	pc	Zylinderschraube Tornillo cilíndrico	Cheese head screw Vis à tête cylindrique	M10 x 20 49Nm/36ft.lbs	ISO4762
4	5000047575	2	pc	Leiste Listón	Bar Listeau		
5	5000047577	4	pc	Buchse Buje	Bushing Douille		
6	5000047578	2	pc	Buchse Buje	Bushing Douille		
7	5000011456	4	pc	Sechskantschraube Tornillo hexagonal	Hexagonal head cap screw Vis à tête hexagonale		
8	5000033356	4	pc	Sechskantmutter Tuerca hexagonal	Hexagon nut Écrou hexagonal		
9	5000031565	2	pc	Spannscheibe Arandela elástica	Lockwasher Rondelle de ressort	12	DIN6796
10	5000011422	2	pc	Sechskantschraube Tornillo hexagonal	Hexagonal head cap screw Vis à tête hexagonale	M12 x 35 86Nm/63ft.lbs	DIN933
11	5100044264	1	pc	Gleitvorrichtung Kpl. Placa de deslizamiento cpl.	Urethane pad kit cpl. Jeu de tapis en polyuréthane		

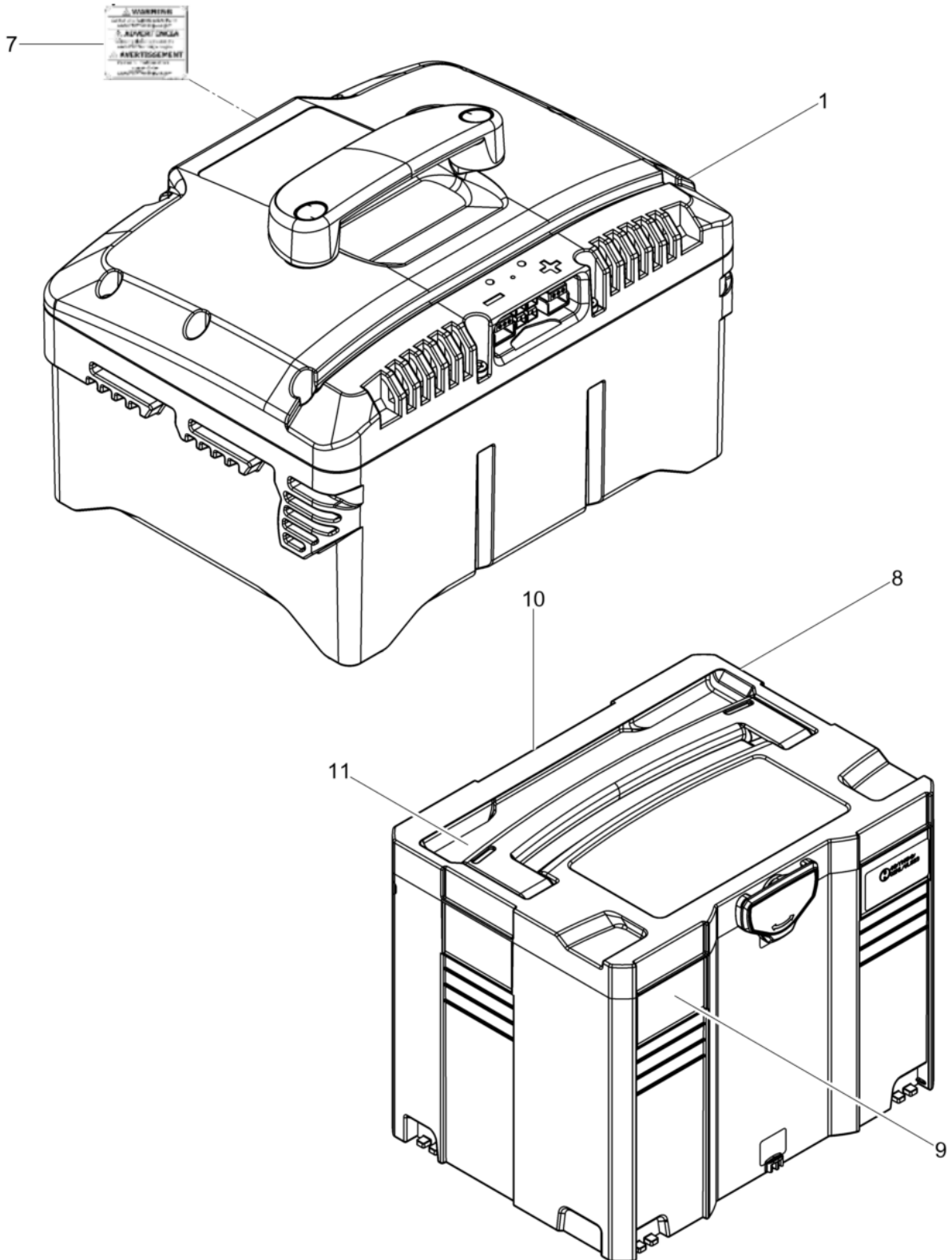



Pos. Ref.	Artikel Nr. Part No.	Qty.	Unit	Beschreibung Descripcion	Description Description	Abm. Measur.	Norm Standard
						Drehm. Torque	Schmierstoff Sealant
1	5100025709	1	pc	Akku BP1000 Bateria bp1000	Battery bp1000 Accumalteur bp1000		
7	5100045462	1	pc	Aufkleber Calcomania	Label Autocollant		
8	5100050600	1	pc	Transportbox Caja de transporte	Transportbox Boîte de transport		
9	5100045462	1	pc	Aufkleber Calcomania	Label Autocollant		
10	5100052073	1	pc	Aufkleber UN3480 Calcomania un3480	Label un3480 Autocollant un3480		
11	5000220000	1	pc	Aufkleber-Warnhinweis Calcomanía-indicación	Instruction label Autocollant avec indication		

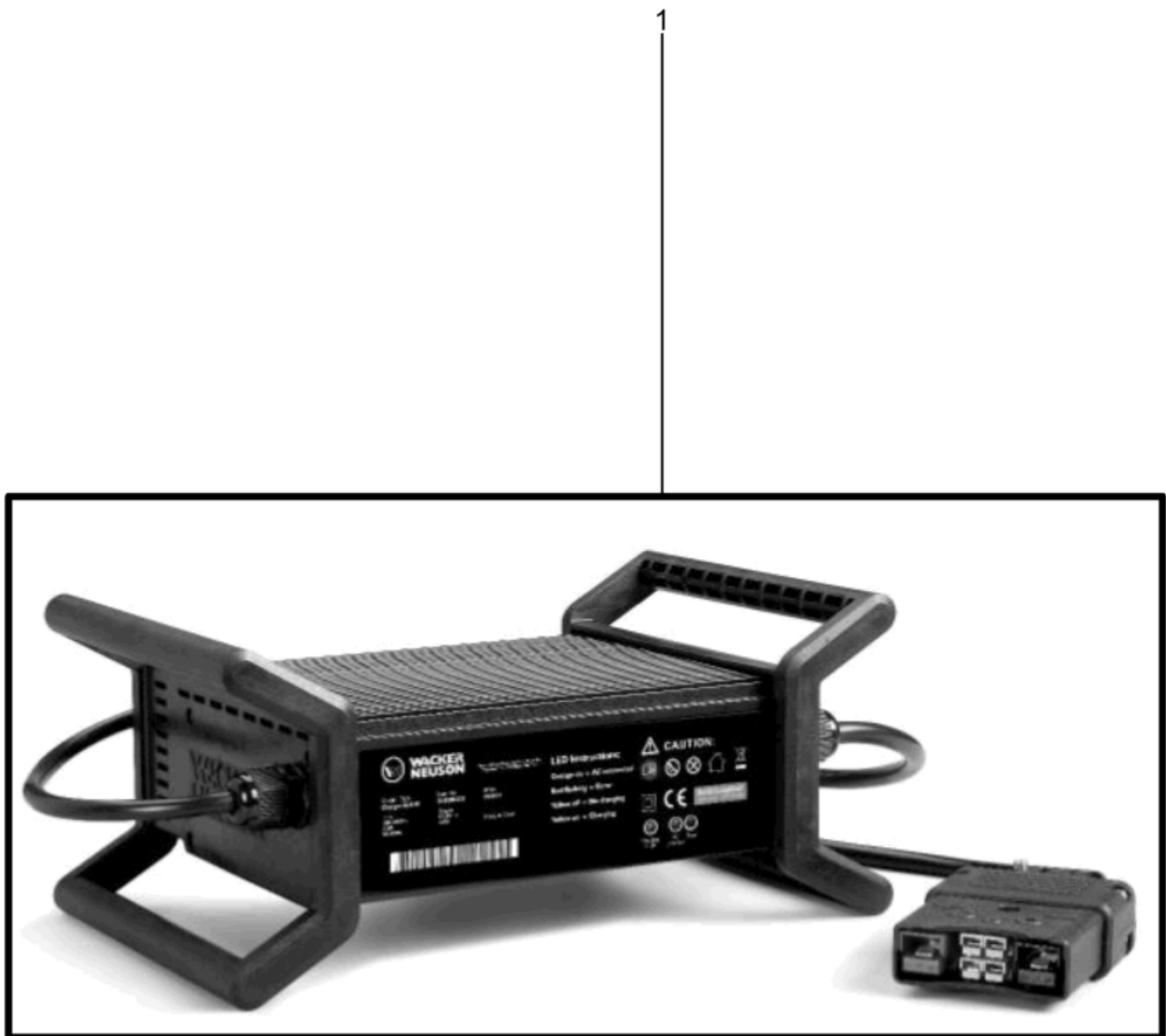

Pos. Ref.	Artikel Nr. Part No.	Qty.	Unit	Beschreibung Descripción	Description Description	Abm. Measur.	Norm Standard
						Drehm. Torque	Schmierstoff Sealant
1	5100006221	1	pc	Ladegerät Cargador par batería	Battery charger Chargeur de batteries		

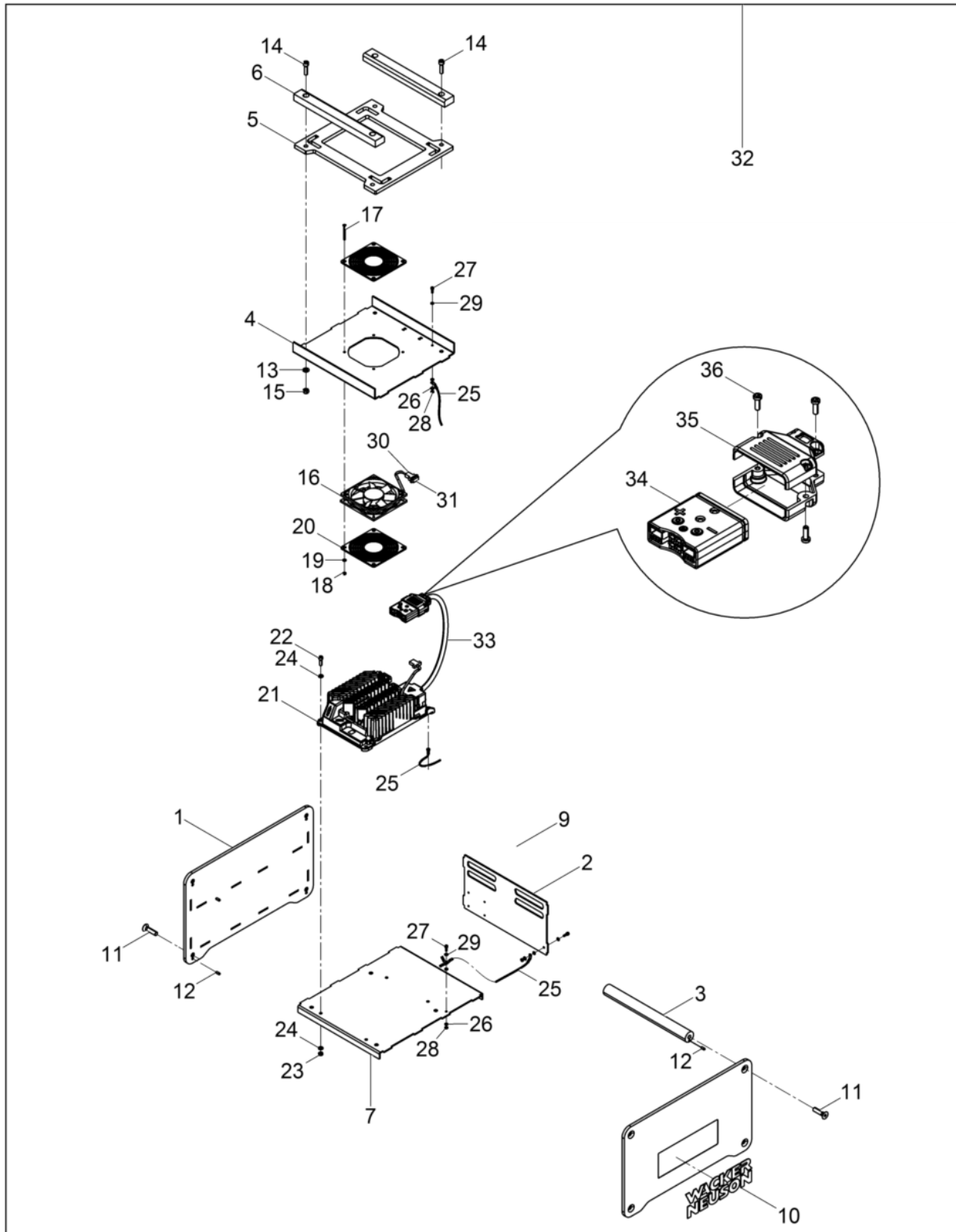

Pos. Ref.	Artikel Nr. Part No.	Qty.	Unit	Beschreibung Descripción	Description Description	Abm. Measur.	Norm Standard
						Drehm. Torque	Schmierstoff Sealant
	5100009484	1	pc	AC Kabel Ac cable	Ac cable Ac câble		
1	5100002644	2	pc	Platte Placa	Plate Plaque		
2	5100002647	1	pc	Blech Chapa	Plate Tôle		
3	5100002673	4	pc	Verbindungsstange Varilla de conexión	Connecting rod Tige de raccordement		
4	5100002703	1	pc	Blech Chapa	Plate Tôle		
5	5100002720	1	pc	Gummiplatte Placa de goma	Rubber plate Plaque		
6	5100003170	2	pc	Leiste Listón	Bar Listeau		
7	5100002789	1	pc	Blech Chapa	Plate Tôle		
9	5000222085	1	pc	Aufkleber Symbol Calcomania símbolo	Label symbol Autocollant symbole		
10	5000222130	2	pc	Aufkleber Logo Calcomania insignia	Label logo Autocollant logo		
11	5000206837	8	pc	Senkschraube Tornillo avellanado	Countersunk bolt Vis à tête fraisée	M10x 40 20Nm/15ft.lbs	ISO10642
12	5000013591	8	pc	Spannstift Pasador de sujeción	Spring pin Goupille élastique	5 x 12	DIN1481
13	5000010622	4	pc	Scheibe Arandela	Flat washer Rondelle		
14	5000011541	4	pc	Zylinderschraube Tornillo cilíndrico	Cheese head screw Vis à tête cylindrique		
15	5000033356	4	pc	Sechskantmutter Tuerca hexagonal	Hexagon nut Écrou hexagonal		
16	5100004447	1	pc	Lüfter Ventilador	Fan Ventilateur		
17	5100005910	4	pc	Senkschraube Tornillo avellanado	Countersunk bolt Vis à tête fraisée	M4x45 1.5Nm/1ft.lbs	
18	5000105210	4	pc	Sechskantmutter Tuerca hexagonal	Hexagon nut Écrou hexagonal	VM4	DIN980
19	5000010628	4	pc	Scheibe Arandela	Flat washer Rondelle		
20	5100005889	2	pc	Schutzgitter Rejilla de protección	Screen grid Grille de protection		
21	5100005836	1	pc	Ladegerät Cargador	Charger Chargeur		
22	5000011551	4	pc	Zylinderschraube Tornillo cilíndrico	Cheese head screw Vis à tête cylindrique		
23	5000010880	4	pc	Sechskantmutter Tuerca hexagonal	Hexagon nut Écrou hexagonal		
24	5000010624	8	pc	Scheibe Arandela	Flat washer Rondelle		
25	5100034450	3	pc	Schutzleiter 2,5 Qmm Toma a tierra 2,5 qmm	Ground wire 2,5 qmm Conducteur de sûreté 2,5 qmm		
26	5100004421	6	pc	Kontaktscheibe Arandela	Contact disk Rondelle	4	
27	5000011571	3	pc	Zylinderschraube Tornillo cilíndrico	Cheese head screw Vis à tête cylindrique	M4 x 12 5Nm/4ft.lbs	ISO4762
28	5000010872	3	pc	Sechskantmutter Tuerca hexagonal	Hexagon nut Écrou hexagonal	M4	ISO4032

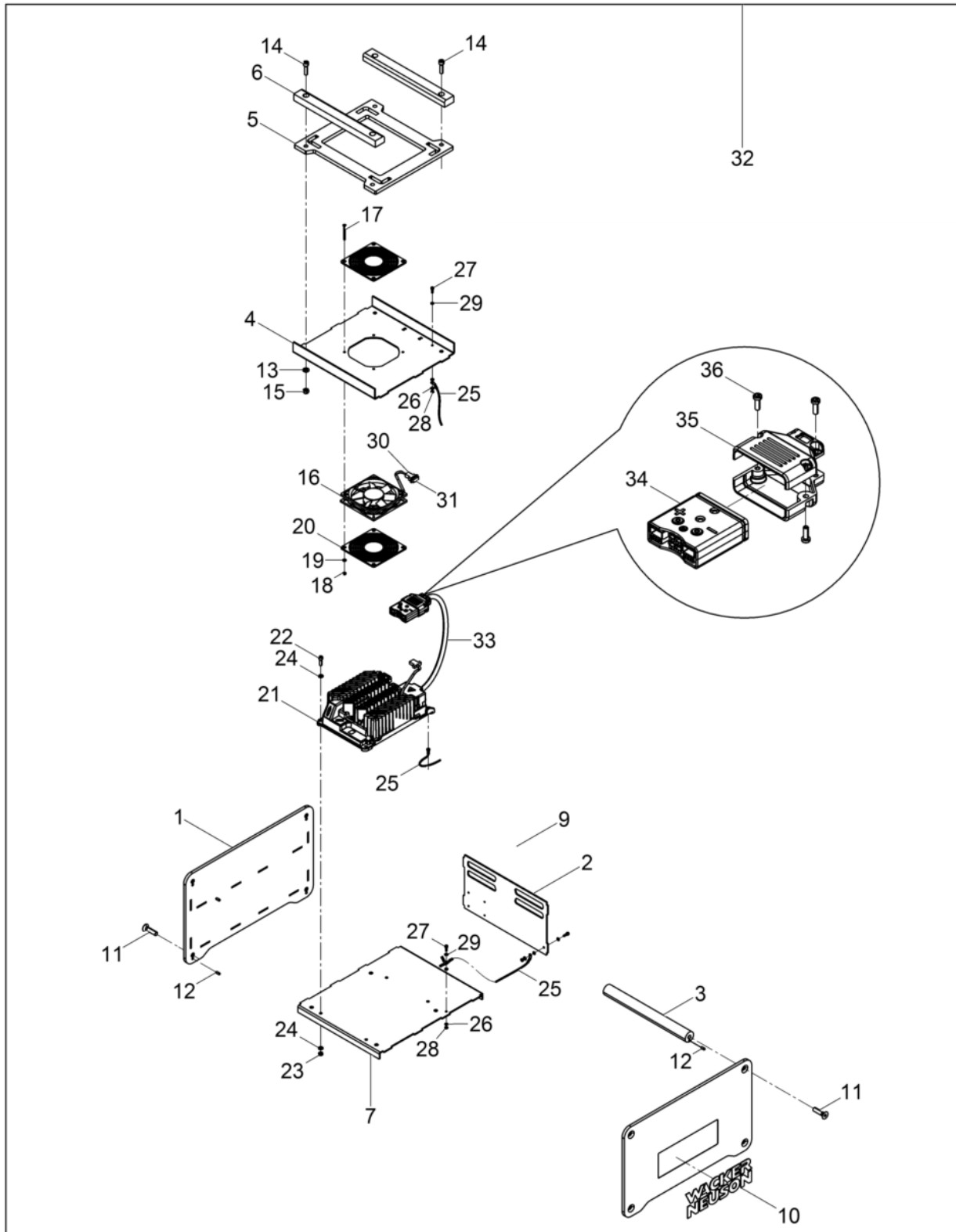

Pos. Ref.	Artikel Nr. Part No.	Qty.	Unit	Beschreibung Descripción	Description Description	Abm. Measuram.	Norm Standard
						Drehm. Torque	Schmierstoff Sealant
29	5000010628	3	pc	Scheibe Arandela	Flat washer Rondelle		
30	5100005908	1	pc	Steckergehäuse Capa	Plug cap Chapeau		
31	5100005909	1	pc	Stecker Enchufe	Plug Prise		
32	5100002543	1	pc	Ladegerät Cargador par batería	Battery charger Chargeur de batteries		
33	5100004465	1	pc	Ladekabel Cable de carga	Charging cable Câble de charge		
34	5100001742	1	pc	Stecker Kpl. Enchufe cpl.	Plug cpl. Prise cpl.		
35	5100008927	2	pc	Zugentlastung Descarga de tracción	Cord grip Effort à la décharge		
36	5000213543	4	pc	Linsenkopfschraube Tornillo gota de seboatado	Oval head screw Vis noyée lentiforme	4x12	

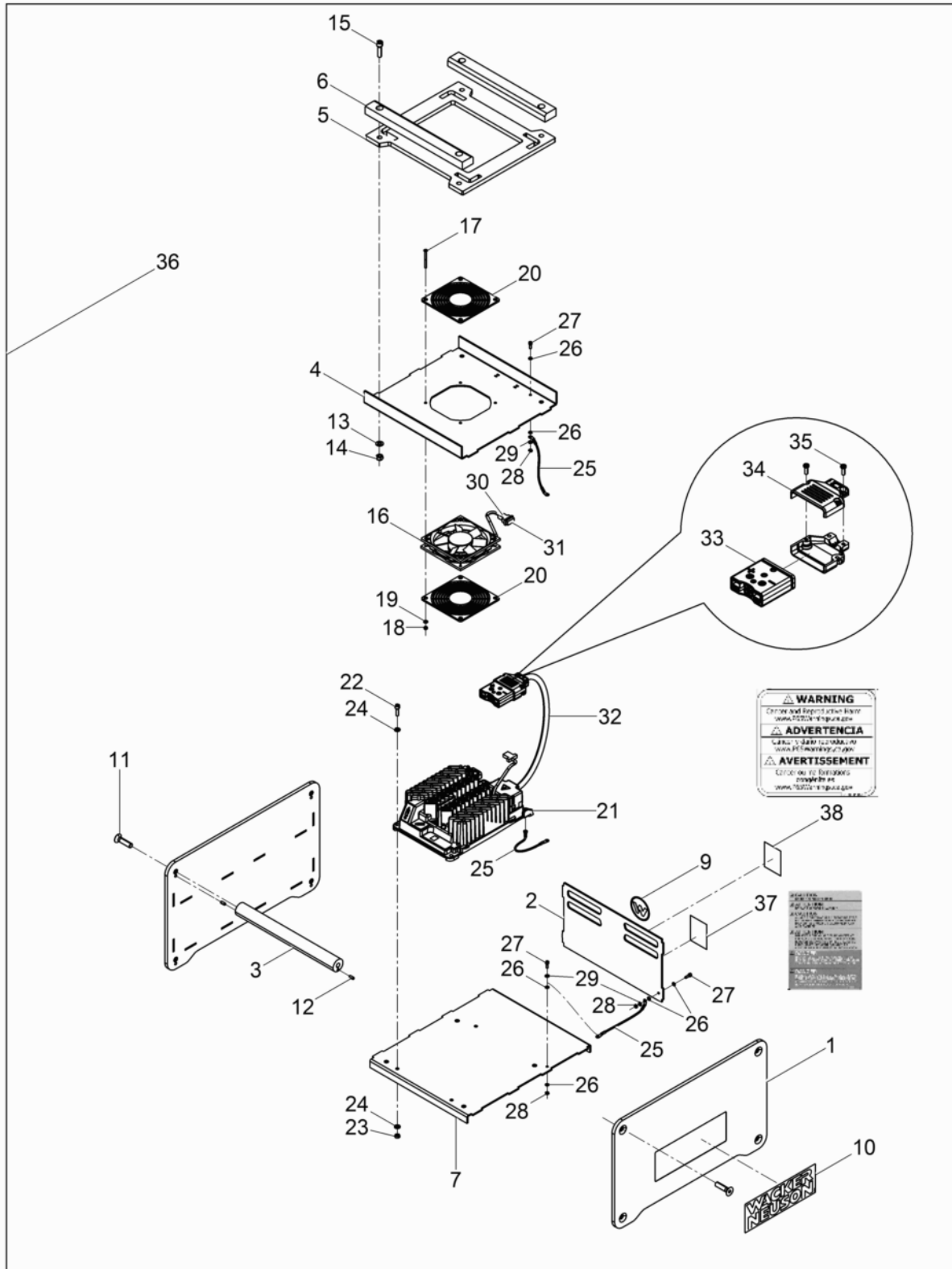



Pos. Ref.	Artikel Nr. Part No.	Qty.	Unit	Beschreibung Descripción	Description Description	Abm. Measur.	Norm Standard
						Drehm. Torque	Schmierstoff Sealant
	5100028195	1	pc	AC Kabel Ac cable	Ac cable Ac câble		
1	5100002644	2	pc	Platte Placa	Plate Plaque		
2	5100002647	1	pc	Blech Chapa	Plate Tôle		
3	5100002673	4	pc	Verbindungsstagne Varilla de conexión	Connecting rod Tige de raccordement		
4	5100002703	1	pc	Blech Chapa	Plate Tôle		
5	5100002720	1	pc	Gummiplatte Placa de goma	Rubber plate Plaque		
6	5100003170	2	pc	Leiste Listón	Bar Listeau		
7	5100002789	1	pc	Blech Chapa	Plate Tôle		
9	5000222085	1	pc	Aufkleber Symbol Calcomania símbolo	Label symbol Autocollant symbole		
10	5000222130	2	pc	Aufkleber Logo Calcomania insignia	Label logo Autocollant logo		
11	5000206837	8	pc	Senkschraube Tornillo avellanado	Countersunk bolt Vis à tête fraisée	M10x 40	ISO10642
12	5000013591	8	pc	Spannstift Pasador de sujeción	Spring pin Goupille élastique	5 x 12	DIN1481
13	5000010622	4	pc	Scheibe Arandela	Flat washer Rondelle		
14	5000011541	4	pc	Zylinderschraube Tornillo cilíndrico	Cheese head screw Vis à tête cylindrique	25Nm/18ft.lbs	
15	5000033356	4	pc	Sechskantmutter Tuerca hexagonal	Hexagon nut Écrou hexagonal		
16	5100004447	1	pc	Lüfter Ventilador	Fan Ventilateur		
17	5100005910	4	pc	Senkschraube Tornillo avellanado	Countersunk bolt Vis à tête fraisée	M4x45	
18	5000105210	4	pc	Sechskantmutter Tuerca hexagonal	Hexagon nut Écrou hexagonal	VM4	DIN980
19	5000010628	4	pc	Scheibe Arandela	Flat washer Rondelle		
20	5100005889	2	pc	Schutzgitter Rejilla de protección	Screen grid Grille de protection		
21	5100028169	1	pc	Ladegerät Cargador par batería	Battery charger Chargeur de batteries		
22	5000011551	4	pc	Zylinderschraube Tornillo cilíndrico	Cheese head screw Vis à tête cylindrique	95Nm/70ft.lbs	
23	5000010880	4	pc	Sechskantmutter Tuerca hexagonal	Hexagon nut Écrou hexagonal		
24	5000010624	8	pc	Scheibe Arandela	Flat washer Rondelle		
25	5100034450	3	pc	Schutzleiter 2,5 Qmm Toma a tierra 2,5 qmm	Ground wire 2,5 qmm Conducteur de sûreté 2,5 qmm		
26	5100004421	6	pc	Kontaktscheibe Arandela	Contact disk Rondelle	4	
27	5000011571	3	pc	Zylinderschraube Tornillo cilíndrico	Cheese head screw Vis à tête cylindrique	M4 x 12 5Nm/4ft.lbs	ISO4762
28	5000010872	3	pc	Sechskantmutter Tuerca hexagonal	Hexagon nut Écrou hexagonal	M4	ISO4032

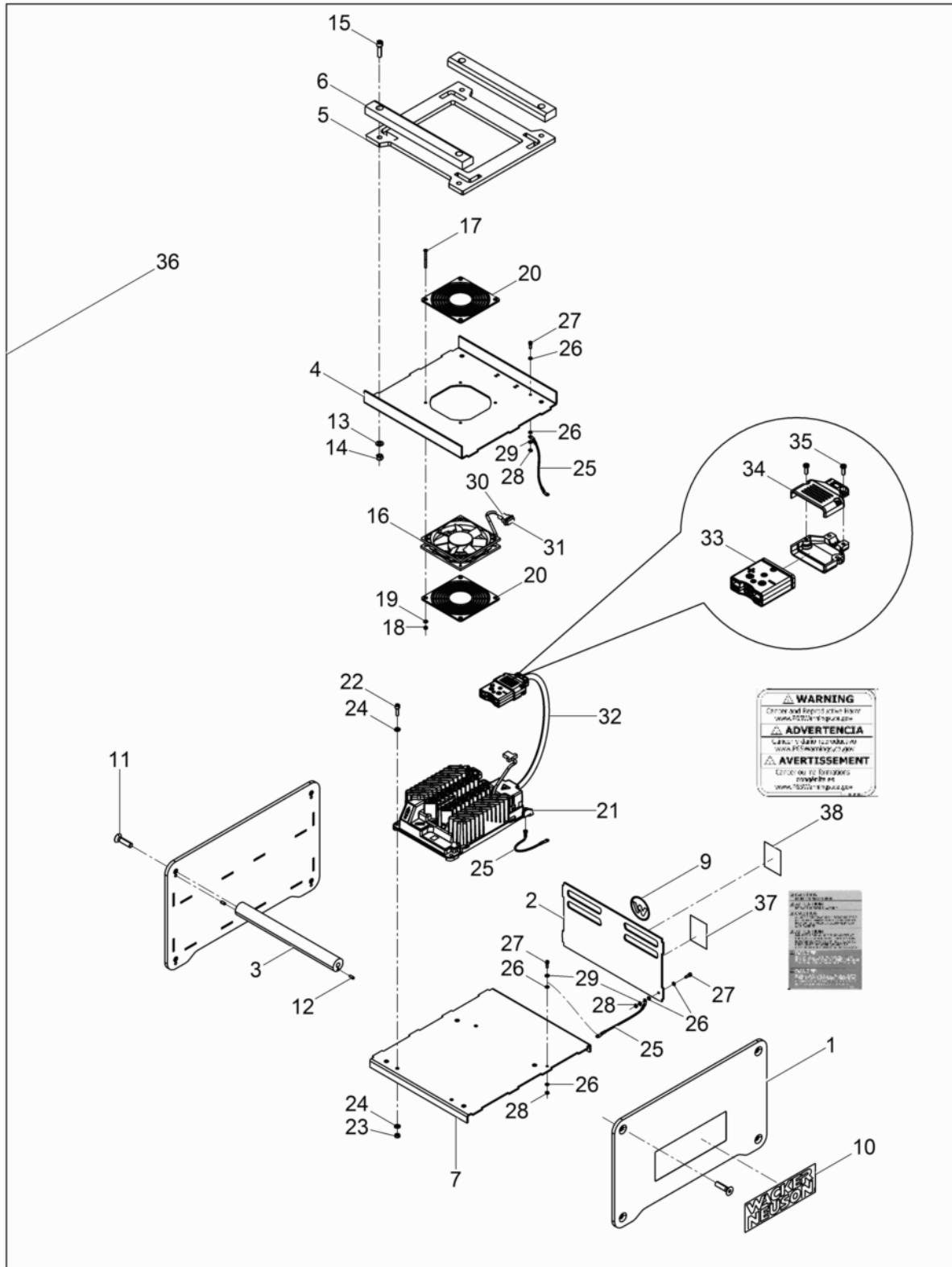

Pos. Ref.	Artikel Nr. Part No.	Qty.	Unit	Beschreibung Descripcion	Description Description	Abm. Measur.	Norm Standard
						Drehm. Torque	Schmierstoff Sealant
29	5000010628	3	pc	Scheibe Arandela	Flat washer Rondelle		
30	5100005908	1	pc	Steckergehäuse Capa	Plug cap Chapeau		
31	5100005909	2	pc	Stecker Enchufe	Plug Prise		
32	5100004465	1	pc	Ladekabel Cable de carga	Charging cable Câble de charge		
33	5100001742	1	pc	Stecker Kpl. Enchufe cpl.	Plug cpl. Prise cpl.		
34	5100008927	2	pc	Zugentlastung Descarga de tracción	Cord grip Effort à la décharge		
35	5000213543	4	pc	Linsenkopfschraube Tornillo gota de seboatado	Oval head screw Vis noyée lentiforme	4x12	
36	5100028231	1	pc	Ladegerät C 48/13 US Cargador par batería c 48/13 us	Battery charger c 48/13 us Chargeur de batteries		
37	5100034432	1	pc	Aufkleber Calcomania	Label Autocollant		
38	5100045462	1	pc	Aufkleber Calcomania	Label Autocollant		

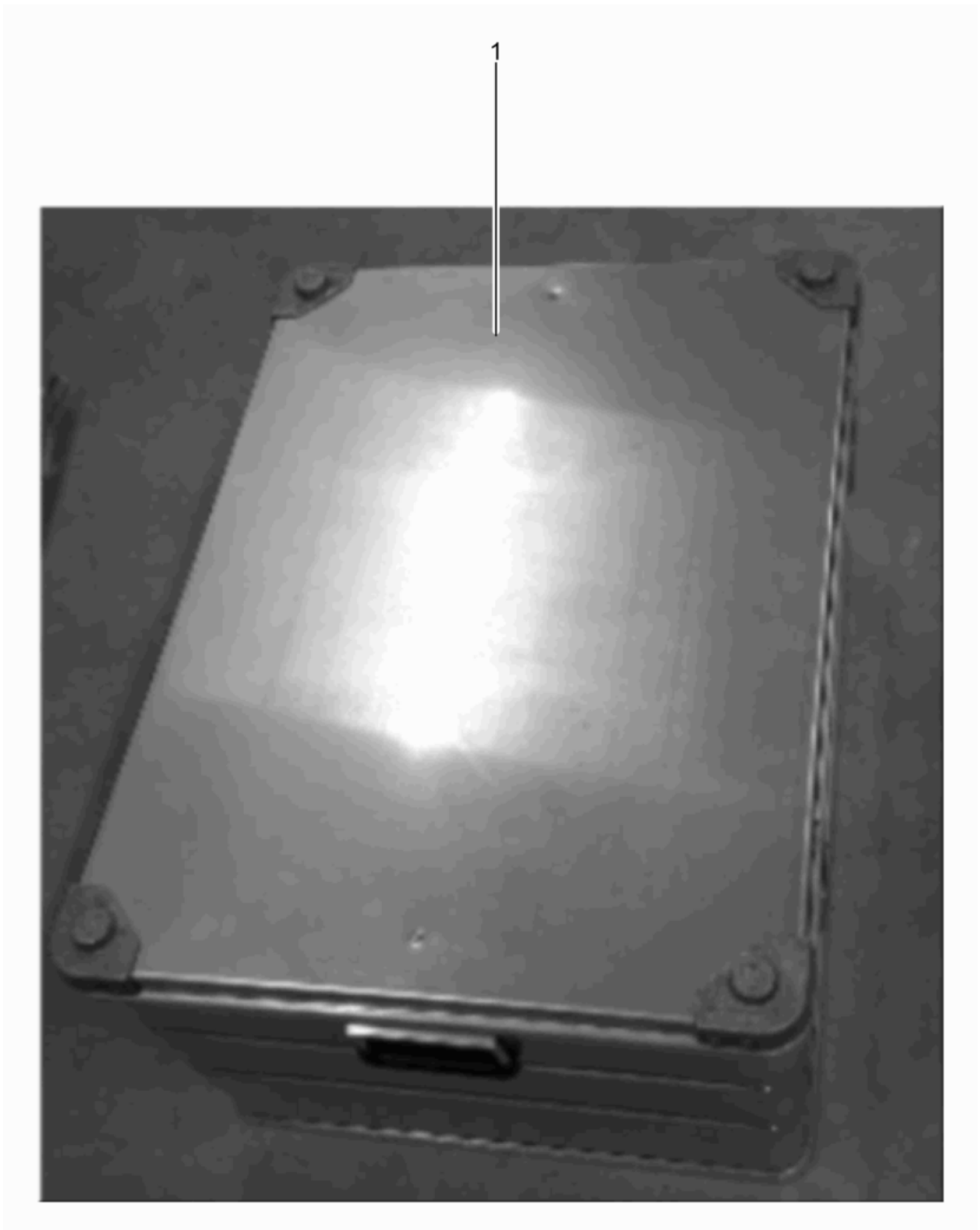

Pos. Ref.	Artikel Nr. Part No.	Qty.	Unit	Beschreibung Descripcion	Description Description	Abm. Measur.	Norm Standard
						Drehm. Torque	Schmierstoff Sealant
1	5100045548	1	pc	Transportkiste Caja de transporte	Handling case Caisse de transport		







**WACKER  
NEUSON**

