

GRUN THE GRUN COMPANY

WWW.GRUNCOMPANY.COM

SB4 STRAW BLOWER



WHY BUY?

Leaf & debris vacuum option – extends usage season by 50%.

Drainage ports in the beater chamber and blower fan housing – reduces water build up and rust.

Powder coat paint – twice as durable as liquid paint when pressure washed.

Heavier gauge steel than competitive models – greater durability.

Slot & groove joinery plus full welds – greater precision & durability.

Fuel tank capacity 80% greater than competition – greater operator productivity.

10% more efficient than competition – increased blower fan size, laser cut and dynamically balanced.

Most compact footprint in the industry – engine protected on the skid.

Manufactured in a high-precision military supplier facility.



PLEASE CALL GRUN OR YOUR LOCAL DEALER FOR MORE INFORMATION, OR VISIT OUR WEBSITE.

WWW.GRUNCOMPANY.COM

T 209.577.1430

SB4 STRAW BLOWER PRODUCT OVERVIEW

GRUN SB4 - TECHNICAL SPECIFICATIONS (SKID MODEL)

- Engine Kohler 20 hp. Electric start.
- Engine safety system Low oil pressure shut off.
- Capacity 3 bales per minute (4 tons per hour).
- Fuel tank 9 gallon (34 liter) high impact poly resin tank.
- Blower fan 17" (43 mm) diameter fan blade.
- Discharge distance Up to 55' (16.8 m).
- Feed Manual.
- Discharge head Dynamic, balanced, 360 degrees horizontal rotation and 60 degrees vertical travel.
- Feed tray Horizontal, collapsible feed tray.
- Weight 800 lbs (362 kg).
- Overall length 60" (1,524 mm).
- Height 63.5" (1,613 mm).
- Width 27" (686 mm).
- Battery 12v.
- Beater chains Three 5/16" hardened welded removable chains.
- Beater chamber 7 cubic feet (0.20 cubic meters).
- Engine meter Tachometer/hour meter standard.
- Leaf & debris vacuum Available as an optional attachment.

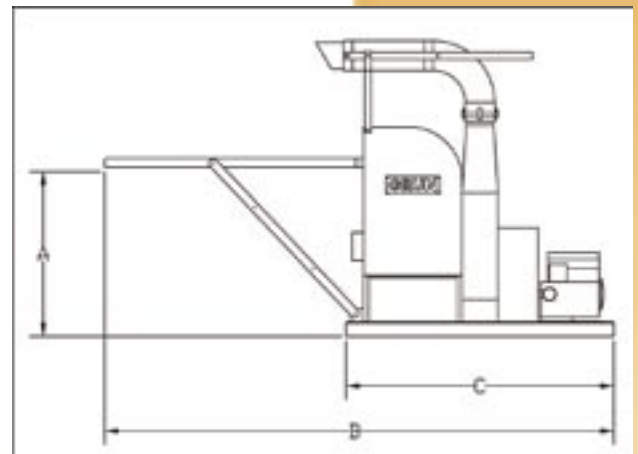
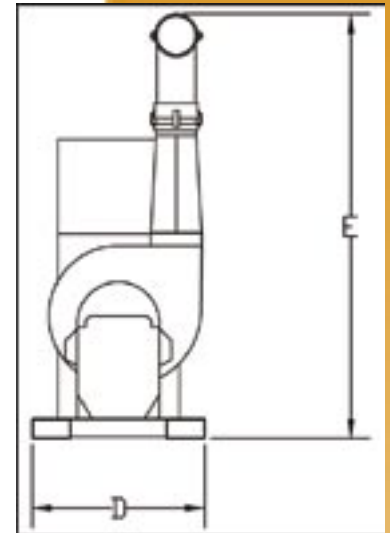

1070 Reno Avenue
 Modesto, CA 95351
 T 209.577.1430 • F 209.577.1573
 info@gruncompany.com

WWW.GRUNCOMPANY.COM