



Click Here To View
Item at

www.GapPower.com

*Sales • Rentals
Parts & Service*

FR1612 ♦ FR1614 ♦ FR1616

12 VDC Diesel Fuel Transfer Pumps



FR1612 Figure 1



FR1614 Figure 2



FR1616 Figure 3



Excellence at work. Excellence in life.

Tuthill Corporation
8825 Aviation Drive
Ft. Wayne, IN 46809
PH: 260-747-7529
FAX: 800-866-4861
www.tuthill.com

DANGER!

- Electrical shock hazard!
- Improper use or installation of this product can cause serious bodily injury or death!
- Electrical wiring should be done by a licensed electrician in compliance with the local, state, and national electrical code, ANSI/NFPA 70, 30, 30A as appropriate.

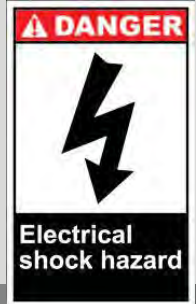

WARNING!

- NOT FOR USE WITH GASOLINE OR ALCOHOL!
- Not for use in hazardous locations
- Improper use or installation of this product can cause serious bodily injury or death!
- Do NOT smoke near pump or use pump near open flame.
- Do not use this product for fluid transfer into aircraft.
- This product is not suited for use with fluids for human consumption or fluids containing water.
- Do not dispense fluid that is thicker than diesel fuel. Motor may overheat!

SAFETY INSTRUCTIONS!

To ensure safe operation safe and efficient operation, it is essential to read and follow each of these warnings and precautions.

- Disconnect power to pump before servicing.
- A diesel compatible filter should be used on pump outlet to ensure that no foreign material is transferred to the fuel tank.
- The pump power cable is equipped with an electrical fuse. If the fuse burns out switch the pump off, disconnect from power, and look for the cause of the failure. Once the cause of failure has been remedied, replace with a 30 amp fuse.
- Tank or barrel should be anchored to prevent tipping in both the full and empty conditions.
- The pump should never be left unattended while running. Once the nozzle lever is closed, the pump should be shut off immediately.

General Description

The Tuthill FR1612 is a positive displacement, rotary vane pump. The pump is designed to run on 12VDC power and supply a flow rate of up to 10 GPM (40 LPM) with diesel fuel. The FR1614 & FR1616 systems consist of the FR1612 pump with accessories.

MECHANICAL INSTALLATION INSTRUCTIONS

- **DO NOT** install additional foot valves or check valves unless they have a pressure relief valve set at 50 psi or less.
- Use oil resistant pipe sealant or PTFE tape on all pipe threads.

Model FR1612

1. Select inlet and outlet hoses or pipes compatible with diesel that can withstand at least 50psi. Ports are 3/4" NPT. Tighten fittings securely to a liquid tight seal.
2. Install the strainer provided at the inlet to the suction hose to prevent debris from being drawn into the pump.
3. Use a nozzle or valve at the end of the discharge hose that can be shut off tightly to prevent accidental siphoning when the pump is not in use.

Model FR1614

1. Install components as shown in Figure 2. Note the direction of flow cast into the front of the pump to determine inlet and outlet.
2. If it is difficult to press the hoses over the barbs, soften the hose by soaking it in hot water for 20 seconds, then slip it over the barbs.
3. Tighten hose clamps securely to provide a liquid tight seal.

Model FR1616

1. Install components as shown in Figure 3. Note the direction of flow cast into the front of the pump to determine inlet and outlet.
2. If it is difficult to press the hoses over the barbs, soften the hose by soaking it in hot water for 20 seconds, then slip it over the barbs.
3. Tighten hose clamps securely to provide a liquid tight seal. Tighten the suction tube into the pump (use PTFE sealant tape).
4. Extend the poly suction tube to a length that will place it a minimum of 3" from the bottom of the tank or barrel.
5. Thread the poly bung into the opening and tighten securely.

ELECTRICAL INSTALLATION FOR ALL MODELS

- Connect the battery clips provided to a suitable 12 Volt DC supply capable of delivering the necessary current and voltage.
- The red clip is attached to the positive (+) battery terminal.
- Black clip is attached to the negative (-) battery terminal or the vehicle frame.
- **DO NOT** employ a patch cord to extend the cables. If the cable provided is not long enough, have it replaced by an authorized electrician.
- The pump may be powered by a battery charger of suitable voltage. To prevent possible fire from sparks, never connect the terminals from the battery charger to the pump directly. Always connect the battery clips from the pump to the terminals on the charger.

OPERATING INSTRUCTIONS

1. Insert nozzle into container to be filled.
2. Switch pump on.
3. Operate nozzle lever to dispense fluid.
4. When the desired amount of fluid has been dispensed, release nozzle lever, remove nozzle from container, and switch pump off.
5. Nozzle should be kept clean and dry, and securely stored when not in use.

PUMP CHARACTERISTICS

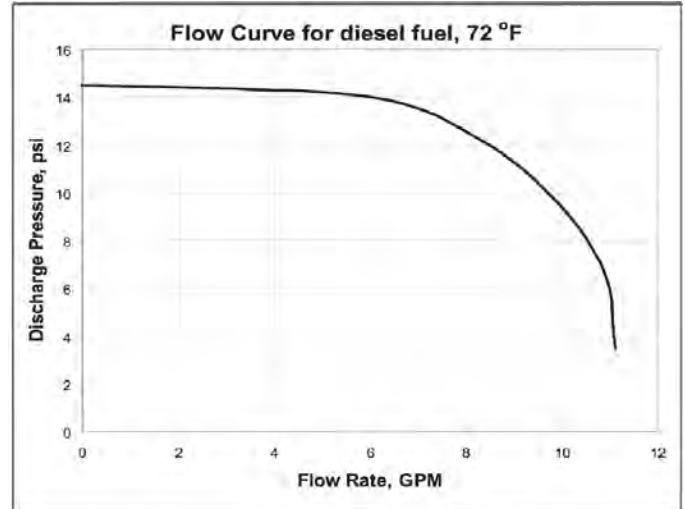

The above flow curve is a guide for pump performance only. Attachment of accessories, changes in fluid pumped, and temperature will affect flow rate delivered.

TROUBLESHOOTING

IF PUMP FAILS TO PRIME:

- Check suction line for leaks or obstructions.
- Check bypass valve for dirt. The valve should slide freely.
- Check electrical connections; the pump will run backwards if the red and black wires are reversed.
- Open nozzle to allow air to be removed from the system.

PUMP IS BOUND:

If the motor hums but the pump does not start, the possible cause is a stuck rotor. Remove rotor cover and check rotor and vanes for dirt.

LOW PUMPING CAPACITY:

- Strainer screen clogged (strainer screen is in top of poly suction tube).
- Bypass valve not seating properly (1).
- Obstruction in suction line.
- Make sure all five vanes slide easily in their slots (2).

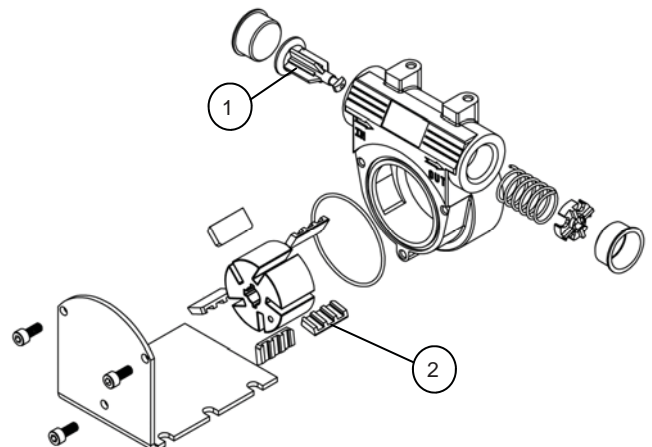

PARTS LIST



FR1612

#	Description	Qty.
1	FR1612 Pump	1
2	6.5' Electrical Cable with Battery Clips	1
3	30 Amp Fuse	1
4	End of Hose strainer (3/4")	1
5	Owners Manual	1

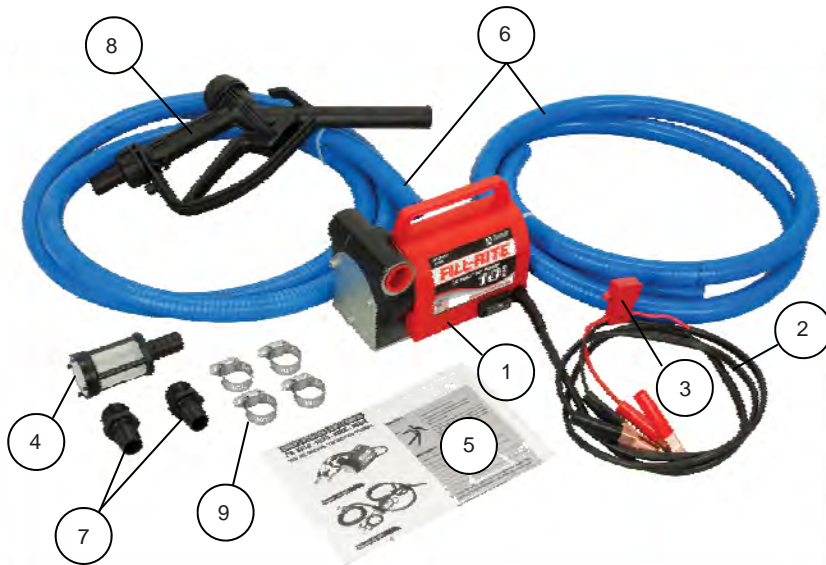

FR1614

#	Description	Qty.
1	FR1612 Pump	1
2	6.5' Electrical Cable with Battery Clips	1
3	30 Amp Fuse	1
4	End of Hose strainer (3/4")	1
5	Owners Manual	1
6	8' x 3/4" PVC Hose	2
7	3/4 NPT x 3/4" Barb Fitting	2
8	Polypropylene Nozzle w/Integral Swivel	1
9	Hose Clamp	4



FR1616

#	Description	Qty.
1	FR1612 Pump	1
2	6.5' Electrical Cable with Battery Clips	1
3	30 Amp Fuse	1
4	Owners Manual	1
5	Polypropylene Nozzle w/Integral Swivel	1
6	Extendable Polypropylene Suction Pipe	1
7	8' x 3/4" PVC Hose	1
8	3/4 NPT x 3/4" Barb Fitting	1
9	3/4 NPT x 3/4" Elbow	1
10	Hose Clamp	2
11	3/4" NPT Pump to Suction Pipe Fitting	1

PRODUCT SPECIFICATIONS

Model Number	FR1612	FR1614	FR1616
Description	12 VDC rotary vane pump only and strainer	12VDC rotary vane pump with hoses, nozzle , strainer, clamps, barbed inlet and outlet adapters.	12VDC rotary vane pump with hose, nozzle, adjustable poly suction pipe, strainer, clamps, barbed outlet adapter.
Warranty	1 Year	1 Year	1 Year
Construction—Pump Housing	Cast Iron	Cast Iron	Cast Iron
Maximum flow rate (with factory supplied hose & nozzle)	Up to 10 GPM	Up to 10 GPM	Up to 10 GPM
Rotor Composition	Iron	Iron	Iron
Motor Horsepower	1/5 HP	1/5 HP	1/5 HP
Amp Draw	20 Amp	20 Amp	20 Amp
Voltage	12 VDC	12 VDC	12 VDC
Fuse in power cable	30 Amp	30 Amp	30 Amp
Inlet	3/4" NPT	3/4" NPT	3/4" NPT
Outlet	3/4" NPT	3/4" NPT	3/4" NPT
Vane Material	Acetal	Acetal	Acetal
Duty Cycle	30 Minutes	30 Minutes	30 Minutes
Internal Bypass valve	Yes	Yes	Yes
Seal Material	HNBR	HNBR	HNBR
Box Contents			
Nozzle	No	Yes	Yes
Hoses	No	Yes	Yes
Poly Suction Tube	No	No	Yes (3/4" NPT)
Strainer for Inlet	Yes	Yes	Yes
Power Cable	6.5' cable with fuse and battery clips.	6.5' cable with fuse and battery clips.	6.5' cable with fuse and battery clips.

PRODUCT WARRANTY

Tuthill Transfer Systems ("Manufacturer") warrants to each consumer buyer of its products (the "Buyer"), from the date of invoice or sales receipt, that goods of its manufacture ("Goods") will be free from defects of material and workmanship. Duration of this warranty is as follows:

Standard Duty Products – One year

Manufacturer's sole obligation under the foregoing warranties will be limited to either, at Manufacturer's option, replacing or repairing defective Goods (subject to limitations hereinafter provided) or refunding the purchase price for such Goods theretofore paid by the Buyer, and Buyer's exclusive remedy for breach of any such warranties will be enforcement of such obligations of Manufacturer. If Manufacturer so requests the return of the Goods, the Goods will be redelivered to Manufacturer in accordance with Manufacturer's instructions F.O.B. Factory. The remedies contained herein shall constitute the sole recourse of the Buyer against Manufacturer for breach of warranty. IN NO EVENT SHALL MANUFACTURER'S LIABILITY ON ANY CLAIM FOR DAMAGES ARISING OUT OF THE MANUFACTURE, SALE, DELIVERY, OR USE OF THE GOODS EXCEED THE PURCHASE PRICE OF THE GOODS. The foregoing warranties will not extend to Goods subjected to misuse, neglect, accident or improper installation or maintenance, or which have been altered or repaired by anyone other than Manufacturer or its authorized representative. THE FOREGOING WARRANTIES ARE EXCLUSIVE AND IN LIEU OF ALL OTHER WARRANTIES OF MERCHANTABILITY, FITNESS FOR PURPOSE OF ANY OTHER TYPE, WHETHER EXPRESS OR IMPLIED. No person may vary the foregoing warranties and remedies except in writing signed by a duly authorized officer of Manufacturer. Warranties or remedies that differ from the foregoing shall not otherwise be binding on Manufacturer. The Buyer's acceptance of delivery of the Goods constitutes acceptance of the foregoing warranties and remedies, and all conditions and limitations thereof.