

LAVINA®



LAVINA® 25G-X User Manual



Tech Support Line: 800-987-8403 | www.superabrasive.com | info@superabrasive.us



WARRANTY CARD

A warranty card must be submitted to Superabrasive within 30 days of purchase in order for the foregoing warranty to apply. See next page for more details on LAVINA warranty and return policies.

Print and mail this form. Or fill out and submit our **ONLINE WARRANTY FORM**

Customer Information

Customer Name

Business Name

Street Address

Street Address line 2

City

State

Zip Code

Phone Number

Email Address

Machine Information

Model

Serial Number

Purchased from / Distributor Name

Purchase date

WARRANTY AND RETURNS

WARRANTY POLICY FOR LAVINA® X MACHINES

A warranty card must be submitted to Superabrasive within 30 days of purchase in order for the foregoing warranty to apply.

You can either mail a hard copy of the warranty card or submit it electronically - see page 2.

Superabrasive warrants, from the time of delivery and receipt by the original customer, new and unused products sold by Superabrasive or Superabrasive-appointed distributors or dealers. Goods shall be free from defects in materials and workmanship. Superabrasive or a Superabrasive-appointed repair facility shall either replace or repair any defects in the Goods resulting from faulty design, materials, or workmanship. Products repaired or replaced during the warranty period shall be covered by the foregoing warranty for the remainder of the original warranty period, or ninety (90) days from date of the repair or shipment of the replacement, whichever is longer. Spare parts for repair will be either new or equivalent to new.

Warranty period shall be 2 years from the time of delivery and receipt by the original customer, or 600 operating hours on the machine - whichever occurs first. Superabrasive will cover the shipping charges for the transportation of the machine to Superabrasive (or an approved repair facility) and back to the customer (within the contiguous 48 United States) in the event that the damage occurs and is reported within 200 operating hours. Shipping charges, if covered by Superabrasive, must be agreed upon in advance and approved by Superabrasive. Thereafter, the customer will have to cover the shipping charges to Superabrasive and back. Superabrasive will not warranty Goods after a period of 2 years from the time of delivery and receipt by the original customer, or 600 operating hours on the machine - whichever occurs first.

Superabrasive shall not be liable for any defects that are caused by circumstances that occur after the Goods have been delivered and whilst the Goods are in the possession of the purchaser. Furthermore, the warranty does not include normal wear and tear or deterioration. Wear parts are not warranted. Superabrasive is not liable for defects arising out of use of non-OEM parts.

The Warranty is void if the purchaser has not followed the maintenance plan stipulated by the machine's manual and warranty card. The warranty is void if the purchaser repairs said Goods himself, or if repairs are conducted by a repair facility that is not approved by Superabrasive. Superabrasive's liability does not cover defects which are caused by faulty maintenance, incorrect operation, faulty repair by the purchaser, or by alterations conducted without Superabrasive's prior written consent. The same applies to any alterations of the Goods or services performed by another party other than Superabrasive, a Superabrasive-appointed distributor, or a Superabrasive-approved repair facility. The warranty is not applicable on a defect that arises due to tools or parts that are not original to Superabrasive. Replaced defective parts shall be placed at Superabrasive's disposal and shall become property of Superabrasive. If such defective parts are replaced within the warranty period, the shipping charges will be covered by Superabrasive. In warranty complaint cases, when no defects are found for which Superabrasive is liable, Superabrasive shall be entitled to compensation for the labor, material cost, and shipping charges, incurred by Superabrasive as a result of the complaint.

The warranty herein is non-transferable, and only applies to the original owner or purchaser of the machine.

RETURN POLICY FOR LAVINA® X MACHINES

The Lavina® X machines may be returned, subject to the following terms:

In no case, a machine is to be returned to Superabrasive Inc. for credit or repair without prior authorization. Please contact Superabrasive Inc. or your local distributor for an authorization and issuance of a return authorization number. This number along with the serial number of the machine must be included on all packages and correspondence. Machines returned without prior authorization will remain property of the sender and Superabrasive Inc. will not be responsible for them. No machines will be credited after 90 days from the date of invoice.

All returns must be shipped freight prepaid. Returned machines may be exchanged for other equipment or parts of equal dollar value. If machines are not exchanged, they are subject to a fifteen percent (15%) restocking fee.

WARRANTY AND RETURNS.....	3	7.MAINTENANCE AND INSPECTION.....	16
1. GENERAL INFORMATION	5	REMARK.....	16
MANUFACTURER	5	MECHANICAL PARTS.....	16
GENERAL DESCRIPTION.....	5	CLEANING.....	16
MACHINE CHARACTERISTICS	5	CHECK HOURLY.....	16
LAVINA® 25G-X MAIN DESIGN.....	5	CHECK DAILY.....	16
ENVIRONMENTAL CONDITIONS.....	6	CHECK AND REPLACE AFTER THE FIRST 8 WORKING HOURS.....	16
VACUUM CONNECTION	6	CHECK AND REPLACE EVERY 50 WORKING HOURS	16
TECHNICAL DATA.....	6	CHECK AND REPLACE EVERY 200 WORKING HOURS	17
TECHNICAL DATA	6	CHECK AND REPLACE EVERY 400 WORKING HOURS	17
2. SAFETY INSTRUCTIONS	6	VACUUM	17
PREPARATION FOR WORK.....	7	WATER LEAKS	17
PROTECTION DEVICES.....	7	MECHANICAL PARTS.....	17
ARREST FUNCTIONS.....	7	ELECTRICAL SYSTEM	17
SAFE USE	7	8. TROUBLESHOOTING	18
PROPANE SAFETY.....	7	8.1 ENGINE	18
FIRE SAFETY.....	7	8.2 CHECKING AND CHANGING OIL.....	18
EMISSIONS.....	7	8.3 SEPARATING THE HEAD FROM THE CARRIAGE.....	18
HAZARD COMMUNICATION.....	7	8.4 DISMOUNTING/MOUNTING THE ENGINE.....	19
LOCAL AGENCIES AND REGULATIONS.....	8	8.5 REPLACING THE CLUTCH	20
BEFORE YOU BEGIN.....	8	8.6 DISMOUNTING TOOL HOLDER TO CHANGING V-RINGS AND FELT-RINGS	20
OPERATING MACHINE.....	8	8.7 DISASSEMBLING AND MOUNTING TOOL HOLDER TO CHANGE BUFFERS AND ELASTIC ELEMENT	21
AFTER WORK IS COMPLETED.....	8	8.8 CORRECTING DEFLECTION OF THE USED PLANETARY CHAIN	22
PERSONAL PROTECTIVE EQUIPMENT (PPE).....	8	8.9 MOUNTING NEW PLANETARY CHAIN	22
PROPANE CYLINDERS	9	8.10 REPLACING THE PLANETARY DRIVING CHAIN WHEEL AND PLANETARY TENSIONER.....	23
REFUELLING CYLINDERS.....	9	8.11 TENSIONING AND REPLACING THE BELTS	24
STORAGE CYLINDERS.....	10	8.12 REPLACING THE PLANETARY DRIVEN CHAIN WHEEL.....	26
TRANSPORTING CYLINDERS	10	8.13 REPLACING THE PULLEY UNITS.....	26
3. HANDLING AND TRANSPORTATION.....	10	8.14 REPLACING THE PLANETARY UNIT	27
ADJUSTING THE HANDLE	10	9. DISPOSAL	27
LIFTING THE MACHINE FROM WORKING TO TOOL MOUNTING POSITION	11	10. MANUFACTURER'S CONTACTS	27
LIFTING	11	11. SPARE PARTS.....	28
STORAGE.....	11	ASSEMBLY AND PARTS SPECIFICATIONS	28
4. OPERATION	12	1. LAVINA® 25G-X GENERAL PARTS.....	28
PRELIMINARY CONTROLS.....	12	2. LAVINA® 25G-X TOP COVER 1 PARTS.....	28
WATER FLOW CONTROL UNIT.....	12	3. LAVINA® 25G-X ENGINE BASE PARTS.....	29
ADJUSTING AND MOUNTING TOOLS.....	12	4. LAVINA® 25G-X TOP COVER 2 PARTS.....	29
ALARM	12	5. LAVINA® 25G-X PLANETARY DRIVE PARTS.....	30
CONTROL BOARD	13	5.1. LAVINA® 25G-X PULLEY UNIT ASSEMBLY	31
THE CONTROL BOARD.....	13	6. LAVINA® 25G-S WATER TANK PARTS.....	31
STARTING THE MACHINE	13	7. LAVINA® 25G-X BOTTOM COVER 1 PARTS.....	31
OPERATING THE MACHINE	13	8. LAVINA® 25G-X TOOL HOLDER PARTS.....	32
STOPPING THE MACHINE.....	13	9. LAVINA® 25G-X BOTTOM COVER 2 PARTS	32
5. TOOLS AND ACCESSORIES.....	14	10. LAVINA® 25G-X CONTROL BOARD PARTS	32
WEIGHTS.....	14	11. LAVINA® 25G-X CARRIAGE PARTS.....	33
TOOL HOLDER KEY	14	12. LAVINA® 25G-X ENGINE PARTS.....	34
FOAM PLATE	14		
SECURITY PLATE FOR QUICKCHANGE PADS.....	14		
6. POPULAR TOOLS.....	15		

1. GENERAL INFORMATION

This owner's manual is intended for the operator of the Lavina® X machine, the servicing technician as well as for anyone involved with operating or servicing the machine. We recommend that you read the instructions very carefully and follow them strictly. The manual includes information about assembling, using, handling, adjusting and maintaining your Lavina® X floor grinding and polishing machine.

MANUFACTURER

Superabrasive was founded in 1987, as a manufacturer of high quality diamond tools for the stone and concrete industry. Today, Superabrasive is one of the world's leading companies in the production of diamond tools and floor grinding machinery. At Superabrasive, we strive to deliver the very best solutions to our customers, and enable them to work more efficiently.

GENERAL DESCRIPTION

The Lavina® X machine is intended for grinding, polishing and buffing concrete, marble, granite, limestone and terrazzo surfaces with diamond tools.

The Lavina® X machine is a three-disc machine, which can be used dry as well as wet.

For best results, use only tools manufactured or recommended by Superabrasive and its distributors. Additionally, the machine could be used for grinding wood floor surfaces.

⚠ WARNING The Lavina® X machine is manufactured and fitted for the above-mentioned applications only! Every other use may possess risks to the persons involved.

MACHINE CHARACTERISTICS

The Lavina® X machine is made of two main component sections:

LAVINA® 25G-X MAIN DESIGN

- **The two main components** are the carriage and main head.

The **handle** on the frame is adjustable in height and allows the operator to work in a correct and safe posture.

- **The halogen spotlight** (Fig.1.2) enables the operator to work in darker areas.

⚠ WARNING Existing lighting system does not replace adequate overhead lighting.

- **The propane tank** is placed on a tank holder on the backside of the frame.
- **The control panel** (fig.1.3) is positioned on top of the frame and contains switching devices, which ensure the proper functioning of the engine, LPG supply turning on/off of the electromagnetic connector/clutch.
- **The water tank** is on the opposite side of the frame, so that the weight of the water does not affect the operation of the machine. The frame weight, on the other hand, is fully absorbed by the driving wheels. An electric pump sprays the water through a front sprayer or internal
- **The Engine Kawasaki FS481V** with electric clutch is mounted on the base plate and it is driving the three heads with a belt system.
- **The planetary motion** derives from the main engine, driven by a simplex roller chain,
- **The self-leveling Guard** is designed to have contact with the surface. Anytime, no matter the height of the tool used.
- **"Quickchange" tool holder** is designed to hold the tools with "Quickchange" connection.
- **The "Foam" tool holder** is designed to hold tools with Velcro connection. It is mounted on each of the three grinding heads with a key lock (butterfly). The Velcro makes changing of tools fast and easy



Figure 1.1



Figure 1.2



Figure 1.3

ENVIRONMENTAL CONDITIONS

The temperature range for operating the Lavina® X machine outdoors is between 41°F and 86°F or 5°C and 30°C. Never use the Lavina® X machine during rain or snow when working outdoors. When working indoors, always operate the machine in well-ventilated areas.

VACUUM CONNECTION

A connection for a vacuum dust extractor is located on the carriage. The Lavina® X machine does not include a vacuum dust extractor. The customer must purchase the vacuum dust extractor separately. The hose of the vacuum extractor must be Ø 50.8 mm and can be glided over the pipe. The vacuum dust extractor must be adapted for floor grinders and have a minimum air displacement of 320m³/h with a negative vacuum of 21 kPa.

TECHNICAL DATA

TECHNICAL DATA	Lavina® 25G-X	
engine	Kawasaki FS481V	
Capacity of engine	603cc	36.8cu.in
Power	13 kW/3600 min	18 hp/3600 min
Tool holder rpm	570-1030 rpm	
Engine rpm	2000-3600 rpm	
Working width	655 mm	25.8"
Tool holder diameter	3x 225 mm	3x 9"
Weight	267 kg	590 lbs
Grinding pressure	160 kg	350 lbs
Additional weight	max 2x29 kg	2x 64 lbs
Application	wet and dry	
Vacuum hose port	Ø 50,8 mm	2"
Water tank capacity	20 l	5.2 gal
Water feed	Peripheral and front stream with pump	
Capacity Propane tank	9kg	20lbs
Machine LxWxH	1930x690x1110 mm	76"x27"x47"
Packing crate LxWxH	1480x820x1560 mm	58.3"x32.3"x61.5"

VIBRATIONS

The vibrations of the machine are within the limits of directives and harmonized standards from the European Union when the Lavina® X is operated with the recommended tools and in normal conditions.

SONOROUS EMISSIONS

The sonorous emissions are within the limits of directives and harmonized standards from the European Union when the Lavina® X is operated with the recommended tools and in normal conditions. However, as previously stated, the operator must wear ear protectors.

LABEL DATA

The data on the label provides the correct Voltage and kW (needed for operational purposes);

Weight (needed for transportation purposes); production year and serial number (needed for maintenance purposes).

CUSTOMER SERVICE

For customer assistance and technical support call your local distributor or call Superabrasive Inc. at 1-800-987-8403 or visit us at: www.superabrasive.com, where you can download a copy of this manual.

2. SAFETY INSTRUCTIONS**RECOMMENDED USE**

The LAVINA® 30GX machine is designed and manufactured to grind and polish concrete, terrazzo and natural stone floors. It can be used for renovations as well as for polishing. The machine is designed for dry or wet use. When using it dry, use a vacuum of appropriate size. For more information, please refer to the chapter on handling the vacuum connection.

PROHIBITED USE

The machine MUST NOT be used:

- For applications different from the ones stated in the General Description chapter.
- In environments which:
 - Possess risks of explosion
 - Possess high concentration of powders or oil substances in the air



- Possess risks of fire
- Feature inclement conditions.
- Possess electromagnetic radiation.
- In nursing homes, hospitals, day-care centers, etc
- In areas where loose tiles or other objects are preventing proper use of the machine.
- In rooms without proper ventilation
- In nursing homes, hospitals, day-care centers, etc
- In areas where loose tiles or other objects are preventing proper use of the machine.
- In rooms without proper ventilation

PREPARATION FOR WORK**WARNING****Make sure that:**

- You have closed the work area, so that no person unfamiliar with operating the machine can enter the area
- The tool plate and tools are mounted on the machine properly
- There are no missing parts of the machine
- The machine is in upright working position
- The protection devices are working properly.

PROTECTION DEVICES**WARNING**

- The machine is equipped with several protection devices including the following:
- A protection skirt and a hood for protecting the tool plates.
- These devices protect the operator and/or others persons from potential injuries. Do not remove them. On contrary, before using the machine, please ensure that all protection devices are mounted and function properly.
- The Envirogard Emissions Monitoring System

ARREST FUNCTIONS**WARNING**

- Functions of arresting of the machine are following:
 - Switch to stop the engine
 - Button to stop the grinding movement
 - Close the propane tank

SAFE USE**WARNING**

The LAVINA® 25GX is designed to eliminate all risks correlated with its use. However, it is not possible to eliminate the risks of an eventual accident with the machine. Unskilled or uninstructed operator may cause correlated residual risks. Such risks are:

- Position Risks due to operator's incorrect working position
- Tangling up Risks due to wearing inappropriate working clothes
- Training Risks due to lack of operational training

PROPANE SAFETY**WARNING**

- Propane is a flammable gas whose vapors are heavier than air. As is the case with gasoline, propane can explode if the proper cautions are not heeded. Propane is odorized with an agent having a distinct odor that is recognizable at very low concentrations. This helps in identifying leaks, even when they are small.
- Awareness and basic safety precautions are required when working with propane. As long as these precautions are followed, risk is negligible. Ignorance, however, could pose needless risk.

- The two greatest hazards with propane powered floor care machines are:
 - **Carbon Monoxide Poisoning:** This is the most frequently reported incident associated with propane powered floor care machines and is caused by excessive exhaust emissions. The symptoms are headache, dizziness and nausea. A major cause involves engines with poor preventive maintenance practices, usually those with dirty air filters and machines operated in confined areas without adequate ventilation. Another cause may be substandard, inexpensive machines with no emissions control technology and improperly set carburetion.
 - **Overfilled Fuel Cylinders:** Nearly all fire related incidents reported result from bringing a cylinder into a building without first checking for overfill. This action is dangerous, unwise, and unnecessary.

FIRE SAFETY**WARNING**

- Be aware of the potential dangers of fire or explosion when using propane, and take normal fire-safety precautions.
 - Fire:** There is a possibility of fire from LPG vapor leaking or venting from fuel cylinders or carburetion equipment.
 - Explosion:** LPG vapor concentrated or confined to a small, restricted space may explode or ignite.
 - Propane** may experience a **BLEVE**, a boiling liquid expanding vapor explosion.

EMISSIONS**WARNING**

- All propane powered floor care machines produce emissions. Most are harmless, but some are dangerous and can be fatal. Carbon monoxide (CO) poses the greatest risk, since CO can be lethal within as little as 30 minutes exposure at 3,000 parts per million (ppm) concentration.
- Carbon monoxide is an invisible, odorless, colorless gas created when fossil fuels (such as gasoline, wood, coal, propane, oil and methane) burn incompletely.

HAZARD COMMUNICATION**WARNING**

- A **Material Safety Data Sheet** for propane shall be posted in all buildings where propane will be used. Because propane is odorized, it is easily detected at levels of just a few parts per million, which is much less than the exposure limit of 1000 parts per million.

If you smell propane while operating a propane floor care machine, do the following:**Stop the engine:**

1. Pull the throttle to the stop position (if present) or turn the key switch to the off position.
2. Shut off the service valve on the propane cylinder.
3. Move the floor machine to a well-ventilated area.
4. Remove the cylinder from the machine and take it outside the building.
5. If the cylinder is leaking, contact a DOT approved repair shop to determine the cause of the leak and have the shop, not you, repair it.

If a fire occurs while the machine is being operated, do the following:

1. Stop the engine: pull the throttle to the stop position (if present) or turn the key switch to the off position.
2. Shut off the service valve on the propane cylinder if possible. Be careful not to be burned.

3. Move the machine outside if possible. If not possible, move it to a well-ventilated area away from flammable materials.

4. Do not attempt to extinguish the flame from a gas leak. If you do, the gas will build up in the area and could re-ignite. Starve the fire by shutting off the supply of gas.

5. HAVE THE MACHINE AND CYLINDER INSPECTED BEFORE USING THEM AGAIN

LOCAL AGENCIES AND REGULATIONS

• NFPA

Operating a propane powered floor care machine requires compliance with certain safety regulations. The National Fire Protection Agency (NFPA) Standard for Storage and Handling of LP Gas is the appropriate authority for safe propane use. A copy of this publication is available through the NFPA in Quincy, MA (1-800-334-3555).

Among its regulations, NFPA #58 requires that all personnel employed in the handling of propane gas be trained in its proper handling and operating procedures. It also requires them to carry a written certification from their employer or training supervisor to attest to such training. Although this is directed mainly to those who fill and transport liquid propane gas, Onyx Environmental Solutions recommends that operators of propane powered floor care machines in public places be trained and certified as well. With regard to operation of propane powered floor care equipment, even though NFPA 58 8-4.5 says "these machines shall be permitted to be used in buildings frequented by the public, including the times when such buildings are occupied by the public," Onyx Environmental Solutions suggests usage when occupancy of a given work area is minimal.

• CARB / EPA

The California Air Resource Board (CARB) and Environmental Protection Agency (EPA) also set limits for propane-powered engines used outdoors, but CARB/EPA approval does not signify that the engine is safe to use indoors.

• CGA

The Canadian Gas Association (CGA) has set a limit of 1500 ppm CO in exhaust flow.

• OSHA

For propane powered machines used indoors, the Occupational Health and Safety Administration (OSHA) has established a limit of 50 ppm CO for 8-hour time weighted average (TWA) in ambient air and is considering a limit of 800 ppm CO in exhaust flow.

• DOT

The Department of Transportation (DOT) has established regulations regarding the safety of fuel cylinders including the ones used on propane powered floor care machines.

• Local Agencies

Local law enforcement agencies such as the local Fire Marshall also rely on independent testing labs such as UL and CGA before giving their approval of the use of some equipment. These labs thoroughly test equipment and submit their stamp of approval only after rigorous testing. While not being required by all law enforcement agencies, the stamp of approval by these agencies further assures the operator that he or she is working with and around safe equipment.



WARNING

NOTE: In order to reduce all consequences of the above-mentioned risks, we advise that machine operators will follow the instructions in the manual at all times.

RESIDUAL RISKS



WARNING

- During the normal operating and maintenance cycles, the operator is exposed to few residual risks, which cannot be eliminated due to the nature of the operations.

BEFORE YOU BEGIN



WARNING

- Working area must be clear from any debris or objects.
- A first-time operator must always read the manual and pay attention to all safety instructions.
- All propane connections and cables must be inspected for potential damages.
- Perform general daily inspections of the machine and inspect the machine before each use.
- Always inspect the safety devices:
- The tool protector must be working
- Mount the security disc when working with Quickchange Pads.
- The machine must be clean
- Never operate the machine in the rain!
- Confirm that there are no missing parts especially after transportation, repair or maintenance.
- Before filling the water tank with water make sure the machine is not working and the main switch is turned off.
- Before turning on the machine make sure that the base is placed on the floor, the machine MUST NOT be in an upright position when turned on!

OPERATING MACHINE



WARNING

- When operating the Lavina® 25G-X, make certain that there is no one, but you around the machine.
- Never leave the machine unattended while working.
- The water hose must move freely and must be damage-free.
- Check if the floor, you work on, is not too uneven. If this is the case, it may damage the machine.

AFTER WORK IS COMPLETED



WARNING

- Clean the machine and its surroundings properly
- Empty and clean the water tank
- Store the machine in a safe place
- Place the Propane bottle outside in its storage
- **THE WORK AREA**
- Make certain that people or vehicles do not enter the work area.
- Avoid cables and hoses being in the way.
- Always check the floor for debris

PERSONAL PROTECTIVE EQUIPMENT (PPE)



WARNING

- Always wear safety shoes when working with the machine.
- Always wear ear protectors when working with the machine.
- All personnel in the immediate work area must wear safety glasses with side shields.
- Always wear safety gloves when changing the tools.
- Always wear clothes suitable for the work environment.
- Always wear Carbon Monoxide Indicator badges as an extra precaution.

- The plastic indicator contains a colored indicator button that darkens in the presence of Carbon Monoxide. The relative darkness of the indicator button indicates the level of CO in the ambient atmosphere. Most indicator badges have a useful life of 30 days, depending on the concentration of contaminants, humidity, and temperature.

TESTING**WARNING**

- There are a great number of instruments offered on the market to test for toxic gases. Only those designed to read carbon monoxide resulting from combustion engines is considered acceptable for testing exhaust emissions from propane powered floor machines.
- Some instruments are used to read “ambient air” and may be damaged if used to take readings in the muffler or tail pipe. Selecting the proper instrument is an important part of meeting the testing requirements.
- Generally speaking, units capable of reading in ppm, (parts per million), at ranges from 0 to 1000 are adequate for checking ambient air (air in the breathing zone of the operator). Instruments capable of testing carbon monoxide in the exhaust should be able to read from 0 to at least 2000 ppm and should be certified by the manufacturer for that purpose.
- Some instruments and systems used for these purposes are:

1) AMBIENT AIR MONITORING

- DRAGER Model 190: Manufactured by National Drager.
- SENSIDYNE gas sampling system with YB-11038 Sensidyne detector tubes
- DRAGER gas sampling system with YB-4620 Drager detective tubes
- GAS-TECH Model CO-95
- ENERAC POCKET 60: Manufactured by Energy Efficiency System

2) ENGINE EXHAUST

- ANALYZERS HORIBA GAS ANALYZER
- ENERAC 2000 COMBUSTION ANALYZER
- ENERAC POCKET 60

3) DATA LOGGERS

- INDUSTRIAL SCIENTIFIC CORP. MODEL STX-70 CO MONITOR, Data-Logger
- BIOSYSTEMS INC. “TEXILOG” Data-Logger

- All instruments used for testing must be calibrated at intervals recommended by the manufacturer. The monitor, model number and date of calibration will be recorded with all test results.

OPERATOR**WARNING**

- The operator must know the machine’s work environment.
- Only one operator at a time can work with the machine.
- The operator must be properly trained and well instructed prior operating the machine.
- The operator must understand all the instructions in this manual.

- The operator must understand and interpret all the drawings and designs in manual.
- The operator must know all sanitation and safety regulations pertaining to the operation of
- The operator must have floor grinding experience.
- The operator must know what to do in case of emergency.
- The operator must have an adequate technical knowledge and preparation.
- The operator is expected to operate their equipment safely and responsibly. They are responsible for the proper handling and storage of propane cylinders, identifying potential hazards associated with his job and avoiding these hazards at all times.

PROPANE CYLINDERS**WARNING**

- The Propane cylinders are constructed of either aluminum or steel. We recommend aluminum because it is lighter and guards against rusting. The cylinder used on propane powered floor machines is classified as a 4E240 cylinder. Its rated capacity is 20 lbs. and this designation refers to the model of the cylinder. Actual propane capacity achieved during filling can be less than, equal to, or slightly more than 20 lbs. Use only UL, CTC/DOT listed cylinders.
- The propane cylinder used on the floor machine is a motor fuel cylinder as listed by the Department of Transportation. Unlike the common 20-lb propane outdoor grill cylinders (which are not legal for use on propane floor machines), the motor fuel cylinder has a number of safety systems designed into it to ensure your safety at all times.
- There are two types of 20 lb. motor fuel cylinders.
 - Liquid draw
 - Vapor draw
- The liquid draw cylinder is used on larger vehicles like forklifts. These machines have special vaporizing carburetors to allow the propane to change from a liquid to a gas before being burned in the combustion chamber.
- The vapor draw cylinder is used on small machines like the propane powered floor care machines. The vacuum generated by the engine draws up the Propane gas vapor through the fuel system. The propane powered floor care machine does not have an evaporating system and will freeze up if liquid propane is introduced to it. It is necessary that special attention be paid to ensure that neither the liquid nor the vapor draw cylinders be overfilled.

REFUELLING CYLINDERS**WARNING**

- The proper filling of propane cylinders is a subject so important that it warrants special attention. Propane cylinders should only be filled by qualified propane dealers.
- Most important, propane cylinders should be filled no more than 80% of their rated capacity. The other 20%, which is about 4” (10 cm) from the top of the cylinder, is called the vapor space or headspace. This vapor can be compressed without causing the pressure relief valve to open and vent gas to the area around the cylinder. If there is no headspace to allow for fuel expansion, the pressure relief valve will open, releasing propane gas into the atmosphere. This is a very dangerous and volatile situation as there is always the possibility that enough of the vented gas could find its way down to the floor and come in

contact with a pilot light from a furnace, hot water heater, or other source of ignition.

Propane changes into a gas, is -44°F (-42° C). Exposing unprotected skin to propane gas or liquid could result in frostbite injury.

- All new cylinders should be vented and purged of air per manufacturer's instructions before use. Never bleed propane cylinders indoors.

STORAGE CYLINDERS



WARNING

- When not in use, propane cylinders always should be stored outside in an upright position in a secure, tamperproof, steel mesh storage cabinet. This cabinet may be located next to the building but with at least five feet (1.5 m) of space between the cabinet and the nearest building opening (door or window), also away from heat and direct sunlight.
- Do not install the cabinet near a stairway or street elevator as vented propane gas will seek a lower level since it is heavier than air and could find its way into the basement of the building. Do not store cylinders full or empty inside a building or inside a vehicle. Although it is unlikely that propane will vent from a stored cylinder, if it should, the vapor could come in contact with an ignition source such as a spark from a power tool or other appliance and create a flash fire.
- Do not smoke or use a device with an open flame when handling or transporting propane cylinders.

TRANSPORTING CYLINDERS



WARNING

- When transporting cylinders to a propane dealer or to a job, make sure the cylinders are securely fastened and standing in an upright position with the service valve closed.
- A cylinder rattling around in the back of a vehicle and banging into other objects constitutes a hazard. Avoid dropping or banging cylinders against sharp objects.
- The propane cylinders are sturdily constructed but a series of hard jolts could cause damage. Please note that any cylinder that has been filled is always considered full, no matter how little propane gas remains in it. This is because even when all liquid has evaporated into vapor there is still some propane gas vapor left in the cylinder. Because this remaining fuel is flammable, an empty cylinder should be treated with the same careful procedures as one that is filled to the 80% level with liquid propane. The only time that a cylinder is considered empty is when it is new, before it has been filled with propane.
- When transporting a propane powered floor machine, the propane cylinder may be strapped onto the machine as long as the machine itself is firmly secured in the vehicle.
- Of course, spare cylinders should always be secured in an upright position.

3. HANDLING AND TRANSPORTATION

ADJUSTING THE HANDLE

The Handle on the frame is adjustable in height and allows the operator to work in a correct and safe posture (Fig. 3.1, Fig. 3.2). Choose the upright position to move easy the machine (Fig.3.2).

The unlocking is by pulling the handle (fig.3.1)The locking is automatically under action of the spring. Fig.3.1.1 shows all possible position of the handle.

To avoid turning the head during transport should be unscrewed the (butterfly, wing-headed) screw and move the lever from the position shown in Fig.3.3a to position Fig.3.3b. When the machine operates the lever must be in position shown in Fig.3.3a, in order to rotate the head when change the tool.



Figure 3.1

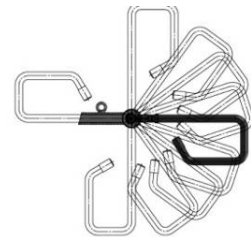

Figure 3.1.1



Figure 3.2

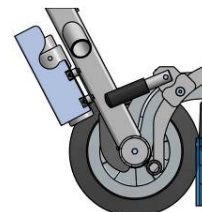

Figure 3.3a

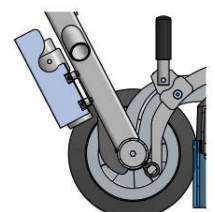

Figure 3.3b

LIFTING THE MACHINE FROM WORKING TO TOOL MOUNTING POSITION



Figure 3.4



Figure 3.5



Figure 3.5.1

Push the front handle down and swivel it to the front (Fig. 3.4). Pull the handle up and ensure the head is a stable upright position, for mounting/dismounting the tool. Ensure that the water tank is empty before flipping the machine. Pull the head in upright position (Fig. 3.5).

LIFTING

Lifting the machine by crane is possible by using the eye bolt mounted on the carriage (see fig. 3.6). The eye bolt and machine construction is rated only for the weight of the machine. Do not lift any other loads on the machine. Use always hoisting equipment rated for 300 kg or 660 lbs.



Figure 3.6

STORAGE

Always store and transport the LAVINA® X machine in a dry place. Never transport the LAVINA® X machine unprotected; it may be damaged if transported unprotected during rain or snow.

⚠ WARNING When during the storage of the machine the temperature may fall down to or less 32F (or 0° C) you should empty the water from the system using following steps:

- Pull out the hose of the tank (Fig.3.7)
- Using compressed air blow out the water from the system for the two positions of the turn-cock (Fig. 3.8, Fig. 3.9).



Figure 3.7



Figure 3.8



Figure 3.9

4. OPERATION

PRELIMINARY CONTROLS

Inspect the working area as explained in the safety instructions. For wet use, fill in the water tank or connect the vacuum extractor and ensure that the vacuum hose is clear and it will follow the machine easily.

Make sure the bonnet air filter on top of the engine is clean. It should be cleaned hourly.

Check the engine oil level, screw the dipstick in to get reading. See to it the tank is fill up (see also "Storage Propane tanks).

TANK and FUEL LINES - The tanks has already been covered but do the fuel lines show any sign of wear and tear, such as cracks or any corrosion. Screw the brass fuel line fitting onto the tank service-valve hand tight only. This connection **MUST** be secure because the service valve has a safety valve inside it, which will only open if the brass fuel-line fitting is **COMPLETELY** seated into the service valve.

WATER FLOW CONTROL UNIT



Figure 4.1



Figure 4.2



Figure 4.2.1

The operator can choose the water sprayer in the front when the tap is in the horizontal position (Fig.4.1), the water will spray under the cover of the machine when the level is in the vertical position (Fig.4.2).The flow regulating valve located on the tank (Fig.4.2.1) is increasing or reducing the water flow to the working area – in front of the machine or under the main head cover of the machine.

ADJUSTING AND MOUNTING TOOLS

The Holder A41 in LAVINA® X can work with either 3 or 6 buffers which will change its elasticity. You can make the change after dismantling the holder as per the instruction in TROUBLESHOOTING.

In Lavina 25G-X the holder is initially mounted with 6 buffers.

Mount the tools only after ensuring that there is enough diamond bond material left. Be sure that the plates are always clean before mounting.

WARNING: Always Secure the "Quickchange" pads with the security plate (Fig.4.3), lock with the tool holder key (Fig.5.3). Diamond tools with Velcro are attached on three foam plates of 9 inch (Fig.4.4). The foam plates are ounted on the key lock (butterfly).Always use the tool holder key (Fig.5.3).

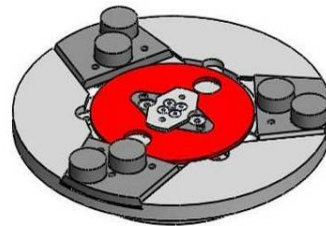

Figure 4.3



Figure 4.4



Figure 4.6

ALARM

EnviroGard employs a sensor (Fig. 4.6) in the exhaust path between the engine and the catalytic muffler to detect the oxygen content of the exhaust before it is passed through the catalyst. The oxygen sensor does not react to nor does it measure the CO content of the exhaust. It responds only to oxygen content.

- The Control Module is set to ignore the readings from the oxygen sensor during the first three minutes the engine is running. This period allows: The sensor to reach a stable operating temperature.
- The catalyst in the muffler to reach the temperature necessary to reduce the levels of CO, nitrogen oxides (NOx) and hydrocarbons (HC) in the exhaust.

The most common event in which the Control Module shuts down an engine is when the air filter becomes dirty enough to restrict the air intake flow, which changes the air-fuel ratio such that the oxygen sensor signal is outside the control limits. Once the air filter is properly cleaned, operation of the machine can be resumed.

CONTROL BOARD

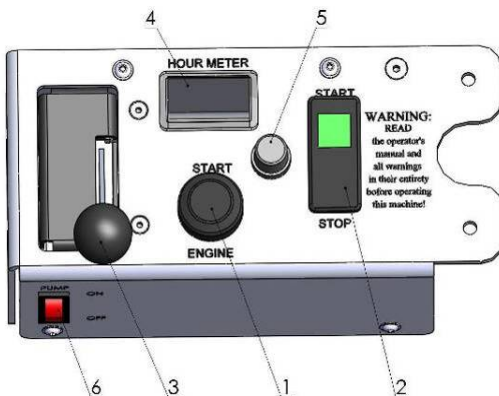

Figure 4.5

THE CONTROL BOARD

1 Start/Stop Engine switch Turn key to the right for contact full right for starting the engine, to stop key to left full left is contact

2 Start/Stop clutch Start will electronically activate the grinding plates to spin, by pushing stop it will disconnect engine from grinding heads

3 Throttle Push forward to accelerate.

4 Digital RPM/workings hours indicator When the motor runs it indicates the revolutions per minute of the motor, see the conversion table to know the rpm of the tools. When the motor does not run, it indicates the worked hours.

The hour meter will blink between 48-52 hours as a reminder for oil change.

5 Fuse Fuse 30 Amps for the electrical system.

6 Water pump switch Lights orange when the water pump is working.

STARTING THE MACHINE

First, follow the directions in chapter Safety Devices and Safety Instructions. Check oil level. Open (counterclockwise) the service valve on the propane tank about one and a half turns. Next, see to it the Start/Stop clutch button (2) is in stop position check the throttle (3) in the **IDLE** position. This creates a vacuum necessary to open the lock-off valve inside the regulator. Actuation of the throttle lever will keep the lock-off valve from opening and the engine from getting fuel so the engine will not start. Proper maintenance will insure easy starting. Engage starter (1) for a **MAXIMUM** of 5 to 6 seconds or until the engine fires. Serious starter damage will result if this is exceeded and the warranty may not apply. Operate the engine at half throttle for approximately two minutes for proper warm-up. Then advance to full throttle for best results. If working wet, add water to the floor surface. If working dry, omit this step, and instead, switch on the vacuum unit. Finally, hold the machine firmly and push the start of the Start/Stop clutch button (2).

OPERATING THE MACHINE

Guide the machine in straight lines across the floor, and with each new line overlap a little bit of the previously completed surface. Work at a constant speed allowing the tools time to work at a speed appropriate for the tools' grit size. Avoid vibrations. Do not stop the LAVINA® X machine in one spot while the tools are still working because they will leave marks on the floor surface. When working wet, open the water tank periodically to release water onto the floor surface. When working dry, check the floor surface periodically to ensure that dust is not accumulating on the surface, also check regularly if your vacuum works properly.

STOPPING THE MACHINE

The stopping of the machine must be done gradually until the motor stops. Do not stop moving the machine before arresting the clutch as the tools could damage the surface. To stop push Stop clutch button (2), then close (clockwise) the service valve on the propane tank. ALWAYS allow the engine to run until it stops from lack of fuel. • ONLY IN AN EMERGENCY should the "stop" position on Start/Stop Engine switch (1) Disconnect the fuel line from the tank. REMEMBER, when you are finished with the machine, store the propane tank outside the building, in a **SECURE** place away from heat or direct sunlight. Use the Emergency button (9) only in emergency or use it to switch the power totally off. Remember not to hold the machine in one spot before turning off until the grinding plates stop moving.

rpm engine	rpm tools
2000	570
2100	600
2200	630
2300	660
2400	690
2500	715
2600	745
2700	775
2800	800
2900	830
3000	860
3100	890
3200	915
3300	945
3400	975
3500	1005
3600	1030

5. TOOLS AND ACCESSORIES

WEIGHTS



Figure 5.1

Superabrasive offers additional weights for increasing the productivity of the machine (Fig.5.1). Each additional weight weighs about 64 lbs or 29 kg. Each individual application, type and condition of surface, power capacity of the outlet, etc. will determine the number of weights you can use without tripping a breaker. The weight stacks on to three posts around the outer bowl (Fig.5.2). The additional weights depend on the tools; it is not always possible to add weights. Some tools work too aggressively and the machine can stop. The weight can be ordered with item number A 08.00.00.00.



Figure 5.2

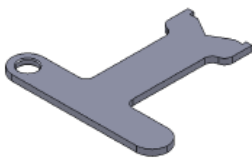

Figure 5.3

TOOL HOLDER KEY

The tool holder key (Fig. 5.3) is used for adjusting, mounting and dismounting of the foam plates. Always use the key for mounting. Item number is A03.00.00.00

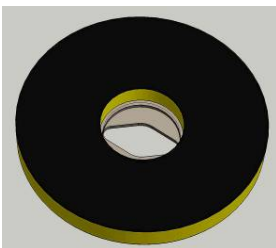

Figure 5.4

FOAM PLATE

Diamond tools with Velcro are mounted on the foam plate (Fig.5.4). The foam plate is mounted on the "QuickChange System" . Item number is LV-9-FP-S

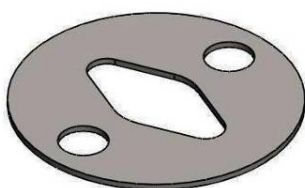

Figure 5.5

SECURITY PLATE FOR QUICKCHANGE PADS

Plate (Fig.5.5) used to ensure the "Quickchange" pads. Item number is A38.00.01

6. POPULAR TOOLS

RECOMMENDED TOOLS



QuickChange System and Tooling feature extremely fast and convenient tool changes, and a long tool life, providing for great long-term cost savings. The QuickChange pads are produced in four different bonds for super hard, hard, medium and soft concrete, in a variety of grit sizes. They are offered with 1 or 2 buttons or rectangular segments, which allows you to customize the aggressiveness of the cut.

Calibra grinding discs: our popular ceramic bond discs are designed for the removal of difficult scratches and they save you valuable time by eliminating the need for multiple passes with metal tools. They can be used wet or dry, and are best for hard concrete applications. They are 3-inch, with included Velcro back attachment.



NATO® polishing discs feature a special resin formula designed for both wet and dry applications and a unique design with wide channels allowing for work on a cleaner surface and ensuring a quality polish. Available in 3 and 4 in sizes. They are with included Velcro attachment.



VHARR® Premium Polishing Pads are designed for mechanically polishing and restoring concrete; also ideal for terrazzo and hard stone floors. VHARR® pads are offered in a wide variety of diameters and grit sizes to accommodate many applications. Dry use is strongly recommended.



Shine Pro® are high quality diamond-impregnated pads for floor maintenance. Available in a variety of sizes, and are great for daily use. When used wet, they require only water (no wax or chemicals needed) and are a very environmentally friendly solution for maintaining floors.

Use only Superabrasive's recommended tools. For more tooling options, visit www.superabrasive.com

7.MAINTENANCE AND INSPECTION

REMARK

Tampering w/Emission Control System Prohibited

Federal law and California State law prohibits the following acts or the causing thereof: (1) the removal or rendering inoperative by any person other than for purposes of maintenance, repair, or replacement, of any device or element at design incorporated into any new engine for the purpose of emission control prior to its sale or delivery to the ultimate purchaser or while it is in use, or (2) the use of the engine after such device or element of design has been removed or rendered inoperative by any person. Among those acts presumed to constitute tampering, involve the parts/systems listed below:

- Carburetor and internal parts
- Spark plugs
- Magneto or electronic ignition system
- Fuel filter element
- Air cleaner elements
- Crankcase
- Cylinder heads
- Breather chamber and internal parts
- Intake pipe and tube

MECHANICAL PARTS

Parts such as the belt, seal rings, cap rings, spiders, buffers, guard assembly, tires are subject to wear and should be replaced as needed.

CLEANING

Keep your machine clean. Cleaning the machine on a regular basis will help detect and solve potential problems before they cause damage to the machine. Most importantly, check and clean the tool plate connections, vacuum hoses, water tank and the Propane installation.

CHECK HOURLY

BONNET FILTER - Make sure the bonnet air filter at the top of the engine is clean. It should be changed hourly and thoroughly cleaned before reuse. The same for the recoil dust filter. If neglected the engine will overheat and carbon monoxide emissions will elevate.

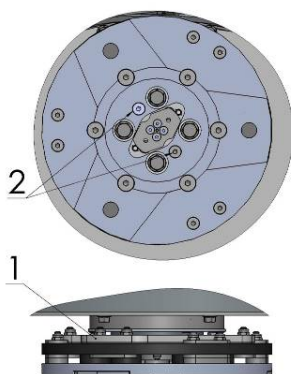

Figure 7.1

CHECK DAILY

After operating the Lavina® X machine, the operator should conduct a visual inspection of the machine. Any defect should be solved immediately. Pay attention to power cords, plugs and vacuum hoses, loose bolt or screws.

Tool holders: Buffers and elastic element are consumables and must be visually checked daily and replaced if needed. See that flanges or discs are mounted and locked well in place. The key lock holders (butterflies) should be also checked.

Check the rubber buffers and fixing of the holders. The flange holding the buffers (Fig.7.1_1) has to be firmly fixed to the unit. A gap seen there means that there are loose screws fixing the holder. The screws have to be tightened immediately for safe operation. Working with loose screws on the holder could also cause bad damages on the machine. Tightening force of the screws has to be 22...25N.m(16...18 ft/lbs).

It is very important to regularly check the screws (Fig.7.1_2) that fix the "Quickchange" holder to the safety part, so that the holder will not fly away if the buffers get damaged.

"Quickchange" should be clean.

CHECK AND REPLACE AFTER THE FIRST 8 WORKING HOURS

Replace the oil in the engine after the first 8 hours work, according to the instructions of the engine manufacturer.

Always use 30HD or 10W30 engine oil with all of the following ratings: SF, SG, and CC

CHECK AND REPLACE EVERY 50 WORKING HOURS

Change engine oil, while changing check for leakage of engine oil at the various seals. The hour meter will blink between 48-52 hours as a reminder. /"Engine Oil Capacity" is 1.5L(1.6US.qt) when oil filter is not removed 1.7L(1.8US.qt) when oil filter is removed/.

Recommended Oil Change Intervals

Do not exceed the 50-hour oil change interval. Oil changes more frequent than 25 hours will give even longer engine life. In any case, always use 30HD or 10W30 engine oil with all of the following ratings: SF, SG, and CC. make sure the oil level is maintained at the "FULL" level.

CHECK AND REPLACE EVERY 200 WORKING HOURS

Every 200 working hours the operator should inspect all parts of the machine carefully. Most importantly, inspect and clean the tool plate connections, vacuum hoses and water tank. Also, check the water flow. Check the guard assembly. Make certain the wheels are clean and rotate properly. Inspect the control buttons. If there are defective control parts, they should be replaced immediately. Replace worn vacuum- and water hoses.

Carefully inspect the seal rings and bearings of the grinding units, and replace any showing signs of excessive wear. For more information, refer to chapter troubleshooting below.

Open the service cover on the motor base (Fig 7.2) (Fig 7.3) to check of the planetary chain. Lubricate the chain with special lubricant for chains and correct the sag if needed. For sagging correction (See TROUBLESHOOTING).



Figure 7.2

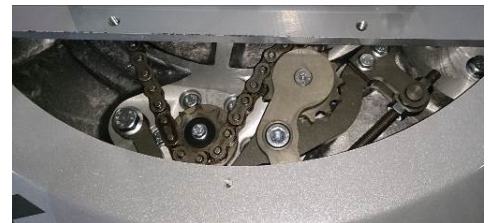

Figure 7.3

Dismount the tool holders (See Troubleshooting) replace all parts (elastic element, buffers, sealers) with the slightest damage or consume. **Return** machine to **authorized service center** for overall checkup of the Engine. For Propane safety, have the machine serviced by a **Certified Technician**, including emission check.

CHECK AND REPLACE EVERY 400 WORKING HOURS

Besides the checks of 200 working hours, replace sealer and V-rings like described in chapter “TROUBLESHOOTING REPLACING BELT AND PULLEY UNITS. Check if belts and bearings are in good condition, change if needed. Return machine to authorized service center for overall checkup of the Engine. For Propane safety, have the machine serviced by a Certified Technician, including emission check.

VACUUM

As stated previously, frequently check hoses and other parts for clogging.

WATER LEAKS

Replace any leaking parts immediately as the water could damage your machine

MECHANICAL PARTS

Parts such as the belts, seal rings, cap rings, spiders and buffers and guard assembly are subject to wear and should be replaced as needed.

ELECTRICAL SYSTEM

Dust should not enter the control box, as it will destroy the contacts. Remove (blow out) any dust present.

Electrical schemes with Kawasaki Engine

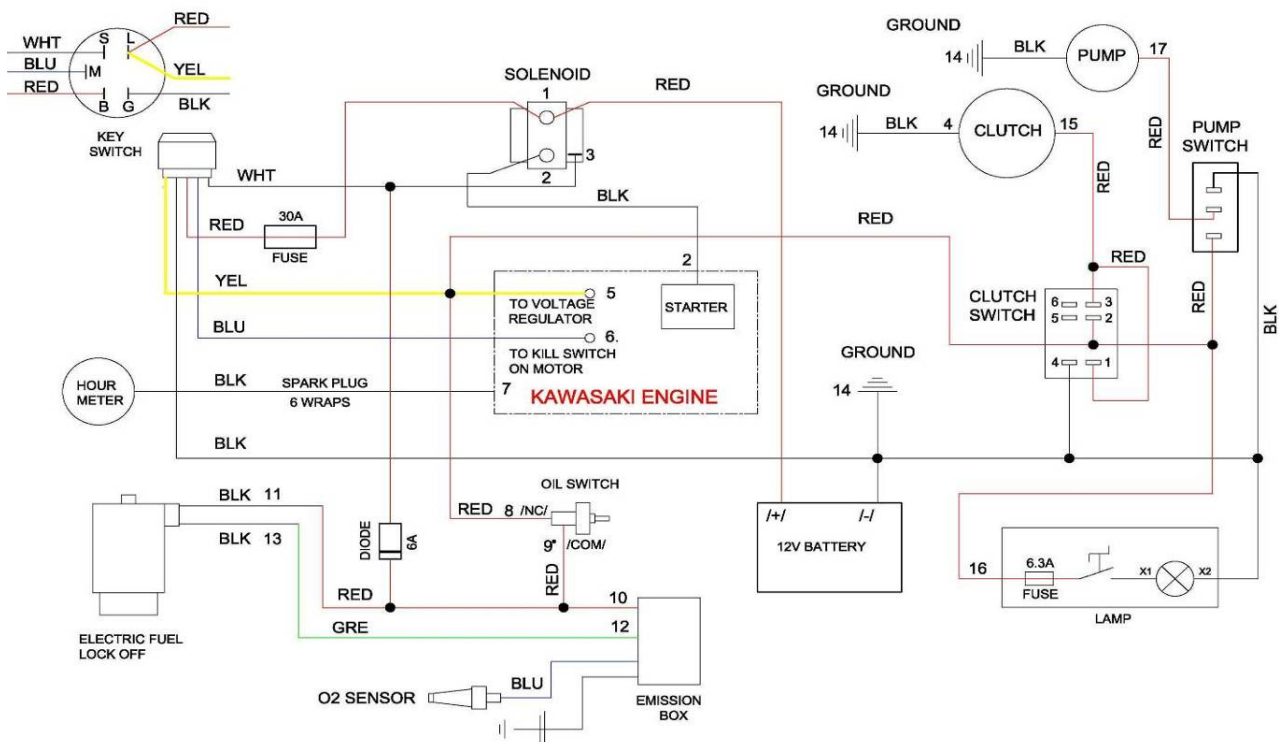

8. TROUBLESHOOTING

8.1 ENGINE

When troubles occur, be sure to check the simple causes which at first, may seem too obvious to be considered. For example, a starting problem could be caused by fuel starvation due to an empty propane cylinder or an unopened service valve. If you do not check for this, starter burnout could result.

Some Troubles and solutions:

Surging idle

To smooth out the engines' idle characteristics, adjustment is provided by an idle screw on the lower left side of the carburetor as viewed from the operator's position. The screw is bright steel and 1/4" in diameter with a Phillips head on it. Rotating the screw clockwise will increase the idle speed and this should cure the "surging idle". If it does not, call our customer service.

Engine starts and idles, but will quit as the throttle is advanced

It is possible that the propane tank's service valve is faulty. To check for this, close the valve completely and then reopen very slowly while you listen for a "click" when the gas begins to travel through the valve. If you hear this very slight noise, the valve is only partially opening. This allows enough gas through to start and idle the engine, but not enough for full throttle operation. As the throttle is increased, allowing more air to enter the intake, the engine will quit from fuel starvation. Call your dealer or the factory for instructions on where to have the service valve replaced. Meanwhile, to get by, you can continue to open the service valve until you do not hear a "click" and then the engine will run normally. If it does not, call your customer service.

Starter barely turns the engine over or the solenoid just clicks

The battery is likely low in charge. This can be remedied by recharging the battery using a 12 Volt battery charger at 4.12 amperes. The battery is located on the left side of the propane tank holder under the battery cover. The positive post is the one with the RED cable attached to it. Follow the instructions that came with the battery charger. REMINDER: this will continue to happen unless your engine is run for sufficient time between starts to recharge the battery

8.2 CHECKING AND CHANGING OIL

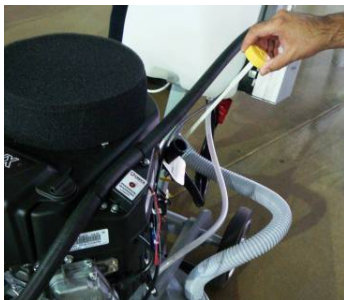

Figure 8.2.1



Figure 8.2.2

Check the engine oil level, screw the dipstick in to get reading. While changing engine oil, check for leakage of engine oil at the various seals. The hour meter will blink between 48-52 hours as a reminder.

Recommended Oil Change Intervals

Do not exceed the 50-hour oil change interval. Oil changes more frequent than 25 hours will give even longer engine life. In any case, always use 30HD or 10W30 engine oil with all of the following ratings: SF, SG, and CC. make sure the oil level is maintained at the "FULL" level.

8.3 SEPARATING THE HEAD FROM THE CARRIAGE

Please note that the propane cylinder has to be removed and stored outside before any maintenance or reparation is done.



Figure 8.3.1



Figure 8.3.2



Figure 8.3.3

Pull the connector of the battery (Fig. 8.3.1), pull out the Propane hose (Fig. 8.3.2), the connectors of the lamp (Fig. 8.3.3), dismount the control panel (Fig. 8.3.4), and take off all water and vacuum hoses (Fig. 8.3.5). Remove the tank (Fig. 8.3.6). Now it is possible to separate the head by removing the pins; two people are needed to do this operation: one person holds the carriage the other pulls the pins (Fig. 8.3.7).



Figure 8.3.4



Figure 8.3.5



Figure 8.3.6



Figure 8.3.7

8.4 DISMOUNTING/MOUNTING THE ENGINE



Figure 8.4.1



Figure 8.4.2



Figure 8.4.3

Separate head from carriage (see previous chapter). Remove front (Fig. 8.4.1) and back belt protection (Fig. 8.4.2). Loose the motor base plate (Fig. 8.4.3), release the tension device (Fig. 8.4.4), and take out the belt (Fig. 8.4.5). Take off the engine (Fig. 8.4.6).



Figure 8.4.4



Figure 8.4.5



Figure 8.4.6

Reassemble in the same manner. (Fig. 8.4.7), Tension the belt with bolt (4) on (fig. 8.4.7) or (fig. 8.4.4) The belt tension can be tested with a Frequency tension Tester Optibelt 3 TT- (190-200Hz) or manual by pushing with a force of 6 kg or 13 lbs in point A, the deflection of the belt must be 3,1 mm or $\pm 1/8$ Inch

ATTENTION:
NEVER "OVER" TENSION THE BELT, THE BELT WILL BE DESTROYED AND IT WILL NEVER RECOVER ITS ORIGINAL TENSION

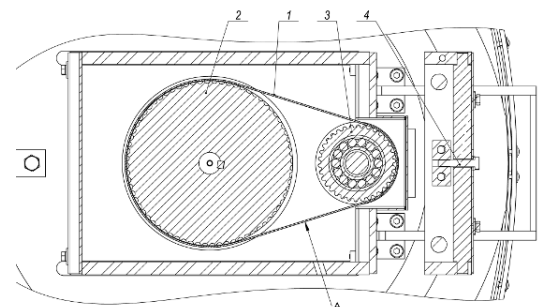

Figure 8.4.7

8.5 REPLACING THE CLUTCH

Figure 8.5.1



Figure 8.5.2

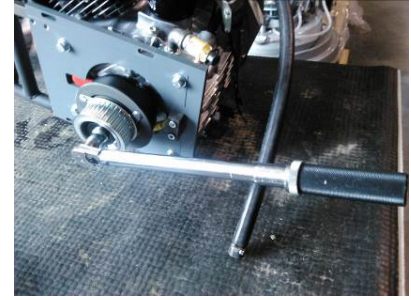

Figure 8.5.3



Figure 8.5.4

In case the electric clutch has to be replaced, remove the engine (see previous chapter) and lay it on its side with the oil drainage up (Fig. 8.5.1) and loose the front nut to dismount the clutch (Fig. 8.5.2 and Fig. 8.5.3). Reassemble in the same manner. Do not forget to mount back the washer on the shaft (Fig. 8.5.4). The torque on the front nut (Fig. 8.5.3) to mount the pulley and clutch should be 70 Nm or 52 ft lbs(Fig. 8.5.2 and Fig. 8.5.3).

8.6 DISMOUNTING TOOL HOLDER TO CHANGING V-RINGS AND FELT-RINGS

Figure 8.6.1



Figure 8.6.2

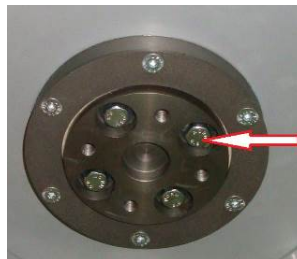

Figure 8.6.3

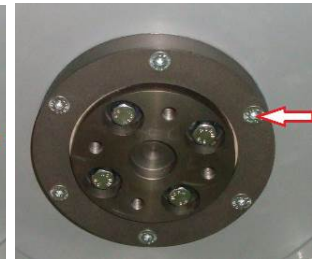

Figure 8.6.4



Figure 8.6.5



Figure 8.6.6

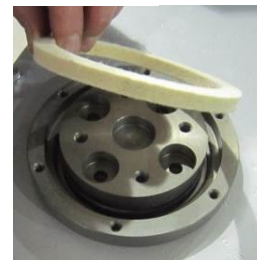

Figure 8.6.7

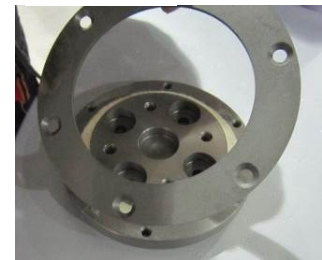

Figure 8.6.8

To check or replace the buffers and the elastic elements , the tool holders have to be dismantled.

You will need deep metric socket 13mm with outside diameter not more than 3/4in to unscrew the four bolts (Fig.8.6.1) and remove the holder (Fig.8.6.2)

When the tool holder is dismantled, you can change the sealers (V-Ring and Felt-Ring).

By loosening four Hex cap flange bolts (Fig.8.6.3) the adaptor comes loose: Unscrew the six screws of the cap (Fig.8.6.4) holding the felt-ring. Take out the Felt-Ring, adaptor and V-Ring.

Mount the V-Ring with the smallest lip of the V to inside (Fig.8.6.5) just push the V-Ring so the top is on the same level as the pulley top (Fig.8.6.6). Then take the adaptor and push the V-Ring down with the adaptor (Fig.8.6.7). The lowest lip of the V-Ring should only barely touch its gliding surface; also never push the V-Ring down with fingers. Mount the adaptor and the Felt-Ring on top (Fig.8.6.7). Close the sealers with the cap (Fig.8.6.8) and screw the bolts. Always use the original bolts.

8.7 DISASSEMBLING AND MOUNTING TOOL HOLDER TO CHANGE BUFFERS AND ELASTIC ELEMENT

When the TOOL HOLDER is disassembled you can change defective parts – elastic element, buffers, etc.

Lift the locking pin (Fig.8.7.1) to dismount the retaining washer (Fig.8.7.2). Take out the screws on the buffers and the nuts of the elastic element (Fig.8.7.3;Fig.8.7.4).

Remove the elastic element from the QC plate (Fig.8.7.5). While the holder is dismantled (Fig.8.7.6;Fig.8.7.7) clean the parts and replace the defective with new ones. Assemble the holder with new buffers with new screws and new elastic element. Put the retaining washer (Fig.8.7.8) and push the locking pin (Fig.8.7.9). This will prevent the fall of the washer when mounting the holder on the machine.



Figure 8.7.1



Figure 8.7.2

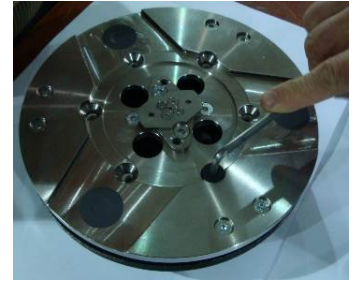

Figure 8.7.3

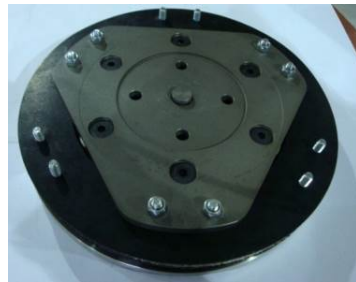

Figure 8.7.4



Figure 8.7.5



Figure 8.7.6



Figure 8.7.7



Figure 8.7.8



Figure 8.7.9

Make sure the four bolts holding the adaptor (Fig.8.7.12) are reliably tighten. Mount the holder

on the machine using the same socket as mentioned in 8.6 (Fig.8.7.10;Fig.8.7.11). The retaining washer fits into the central hole C of adaptor and the four bolts into the thread holes T (Fig.8.7.12). The holder is centered on the outside diameter of the adaptor. Ensure the connection of the holder on the forehead of the adaptor and then tight evenly the four bolts. Tightening force of the bolts has to be 22...25N.m(16...18 ft/lbs). Mounting the holder without retaining washer (Fig.8.7.2) is **INADMISSIBLE** because the security system preventing the separation of part of the holder in case of broken buffers and elastic element will not function! You can change the butterfly of the holder without dismantling the holder of the machine. Fig.8.7.13 is 3-d section view of the holder, showing its parts. The numbering is the same as in Spare parts.



Figure 8.7.10



Figure 8.7.11

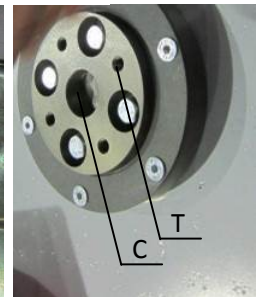

Figure 8.7.12

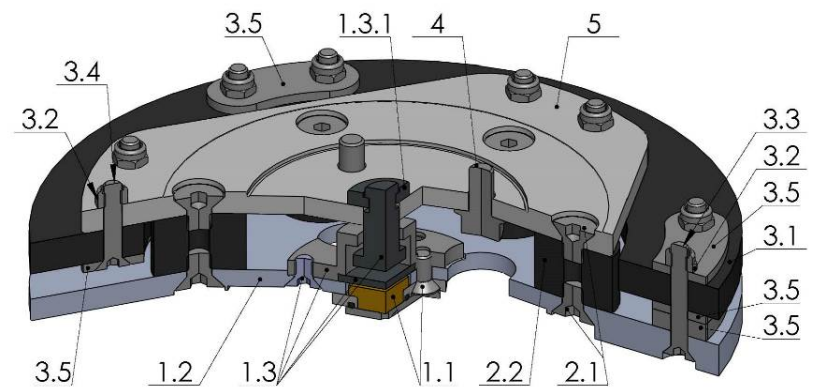

Figure 8.7.13

8.8 CORRECTING DEFLECTION OF THE USED PLANETARY CHAIN

Unscrew the eight bolts (Fig.8.8.1) and take out the cover (Fig.8.8.2) and pull out the hose of the water sprayer(Fig.8.8.3). Lift the machine in position to change the tools. Turn manually the holders in order to turn the main head, stop when you see through the window the chain tensioner (Fig.8.8.4).



Figure 8.8.1



Figure 8.8.2



Figure 8.8.3



Figure 8.8.4

Loosen a quarter to 1/2 rev the two bolts of the chain tensioner (Fig.8.8.5) the tensioner should turn with minimum clearance, without inclination, then unscrew the inner nut. To tension the chain screw the outer nut (Fig.8.8.6). The tensioner of the planetary chain should allow chain sagging 3...5mm/1/8...3/16 in/ controlled in span X (Fig.8.8.7). When ready screw the two nuts (Fig.8.8.6) and the screw(Fig.8.8.5).



Figure 8.8.5



Figure 8.8.6

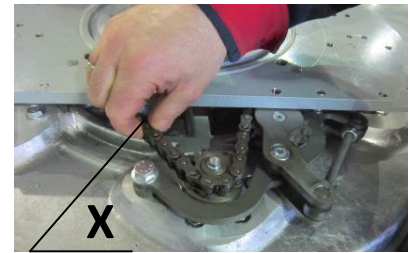

ATTENTION: NEVER “OVER” TENSION THE CHAIN, THE CHAIN WILL BE DAMAGED

8.9 MOUNTING NEW PLANETARY CHAIN

The planetary chain is replaced with new one when the step/drive of the chain tensioner is finished or there is a break in the integrity of the chain. Unscrew the eight bolts (Fig.8.8.1) and take out the cover (Fig.8.8.2) and pull out the hose of the water sprayer (Fig.8.8.3). Lift the machine in position to change the tools. Turn manually the holders in order to turn the main head, stop when you see through the window the chain tensioner (Fig.8.8.4). Separate the carriage from main head, point 8.3 , pull out motor plug, water tubes and vacuum tubes. Take off handle (without water tubes) (Fig. 8.8.3). Release the pin sets which attach the head to the carriage. Take off the weight holders(Fig. 8.9.1), machine support(Fig. 8.9.2) and the service window (Fig. 8.8.2) so you can dismount the top cover(Fig. 8.9.3)



Figure 8.9.1



Figure 8.9.2



Figure 8.9.3

Loosen the two nuts(Fig.8.8.6) and unscrew the two screws of the tensioner (Fig.8.8.5)(Fig.8.9.4)(Fig.8.9.5). Take the chain tensioner(Fig.8.9.6). Pull out the split pin (Fig.8.9.7) and the chain link pin (Fig.8.9.8) (Fig.8.9.9). Take the chain, and put on the same way the new chain, get in the chain link pin and the split pin (Fig.8.9.9) (Fig.8.9.8) (Fig.8.9.7).



Figure 8.9.4



Figure 8.9.5



Figure 8.9.6

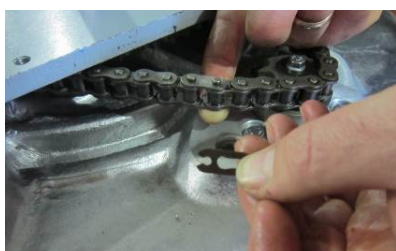

Figure 8.9.7



Figure 8.9.8



Figure 8.9.9

Mount the chain tensioner (Fig.8.8.6). Screw the two screws (Fig.8.9.4)(Fig.8.8.5). Loosen a quarter to 1/2 rev the bolt of the chain tensioner (Fig.8.8.5) the tensioner should turn with minimum clearance, without inclination, then unscrew the inner nut. To tension the chain screw the outer nut (Fig.8.8.6) . The tensioner of the planetary chain should allow chain sagging 3...5mm/1/8...3/16 in/ controlled in span X (Fig.8.8.7).

When ready screw the two nuts (Fig.8.8.6) and the screw(Fig.8.8.5).

ATTENTION: NEVER “OVER” TENSION THE CHAIN, THE CHAIN WILL BE DAMAGED

8.10 REPLACING THE PLANETARY DRIVING CHAIN WHEEL AND PLANETARY TENSIONER

Check and repeat the instruction in 8.9 MONTING NEW PLANETARY CHAIN.

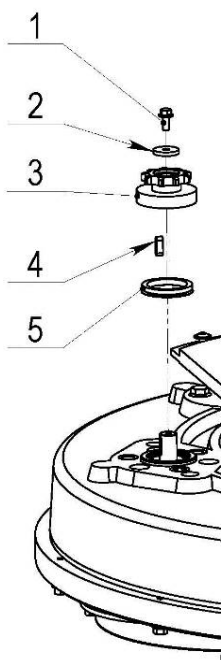

Figure 8.10.1

Unscrew bolt pos.1 take the chain pulley pos.3 together with the sealer pos.5. Change the sealer and mount it to the chain pulley pos.3. Apply lithium grease on the shaft and mount back the wheel and the front washer pos.2 as shown on (Fig.8.10.1). Screw the bolt by using always the “blue” thread locking adhesive. Tightening force of the bolts has to be 22...25N.m(16...18 ft/lbs).

8.11 TENSIONING AND REPLACING THE BELTS



Figure 8.11.1



Figure 8.11.2



Figure 8.11.3

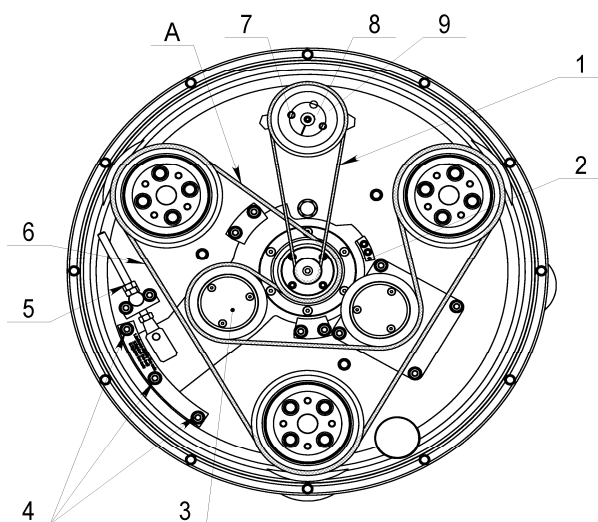

Figure 8.11.5

The transmission of the machine has two timing belts (main belt and planetary belt) of maintenance free type. To change the main belt you have to remove all holders and dismount their adaptors. Dismount the sealing. Carefully check the friction surface (flanges of the lower cover and the outside diameter of the adaptors). Decide if they are in good condition (wear out, smoothness of surface) and whether they can work until next inspection. Remove the bottom cover, unscrew the bolts on the outskirts and the three bolts of the spacers (Fig. 8.11.1). Under the cover on the outskirts there is a sealer, and the spacers have O-Rings. The change of all seals together with the belts is recommended.

Fig.8.11.5 shows the scheme of belts location. To dismount the old belts first dismount the planetary belt pos.1 and after that the main belt pos.6.

To dismount the main belt pos.6 unscrew nuts on pos.4 and pos.5 enough to be able to turn the tensioners pos.3 around the central axle. Clean the washers and space around, and check if all bearings of pulley units or tensioners are in good condition (check for too much clearance or rolling noise). Rotating the tensioner will allow the

centre distance to be reduced in such a way that the timing belt may be fitted without force. Installation with the use of force is NOT permissible at any time as this can damage the high quality, low stretch tension cord and other components. This damage is often not visible. Put the belts in pos.6 as per the scheme, and pay attention for their correct position in every pulley. Screw up until it stops and loosen on the half moons the nuts on pos.4, allowing the rotation of the tensioners at minimum inclination. Using nuts on pos.5 tighten the belt, verifying again the correct position of the belt, and the correct gearing in every pulley.

Rotate the gear while tensioning to allow regular tension distribution on the belt. Control the tension using Frequency tension Tester (Optibelt 3 TT) (Fig. 8.7.3). Tension in span "A" of the belt should be 120-130Hz. It is possible for tensioning while changing the belt to use pre-installed support (Fig.8.11.5-2) (Fig.8.11.6) (only when its factory position is not changed), to limit the turn of the tensioner when the required belt tension is done.

ATTENTION:NEVER "OVER" TENSION THE BELT, THE BELT WILL BE DESTROYED AND IT WILL NEVER RECOVER ITS ORIGINAL TENSION



Figure 8.11.6

To dismount the planetary belt (Fig.8.11.5-1) unscrew the screw of the front washer (Fig.8.11.7) and the two screws of the conical sleeve (Fig.8.11.8). Screw one screw in the free thread(Fig.8.11.9), to push the washer down (Fig.8.11.10); take the conical sleeve and the belt (Fig.8.11.11). You can help with a flat screw driver if the sleeve is not going out easy. (Fig.8.11.12).



Figure 8.11.7



Figure 8.11.8



Figure 8.11.9



Figure 8.11.10



Figure 8.11.11



Figure 8.11.12

The assembly is on reverse order, and is important to match the threads of the conical sleeve and the belt washer(Fig.8.11.13). Put the front washer (Fig.8.11.14), on the screw use always the "blue" thread locking adhesive. Tightening force of the bolts has to be 4,5...6N.m(3,3...4,4 ft/lbs). Put carefully the two binder screws by leaving the central thread free.(Fig.8.11.14)(Fig.8.11.15). Insert the screws up to revolution and ½ by alternating until the conical sleeve pull up the belt pulley. The conical sleeve must be aligned in height with the belt washer(Fig.8.11.16).



Figure 8.11.13



Figure 8.11.14

Dismounting the planetary belt is possible without removing of the Bottom cover assembly. Unscrew the eight bolts, take the service window cover and the sealing(Fig.8.11.17)(Fig.8.11.18). Dismount the planetary belt (see 8.11.)



Figure 8.11.15



Figure 8.11.16



Figure 8.11.17



Figure 8.11.18



Figure 8.11.19

8.12 REPLACING THE PLANETARY DRIVEN CHAIN WHEEL

Dismount the planetary chain and the tensioner and see Fig.8.9(MONTING NEW PLANETARY CHAIN).

Dismount the tool holders, sealers and bottom cover see Fig.8.11(TENSIONING AND REPLACING THE BELTS).

Unscrew the cap that gives access to the fastening bolts of the driven chain wheel (Fig.8.12.1)(Fig.8.12.2). Roll the main head to the position when from the hole of the cap you see a fastening bolt of the driven chain wheel (Fig.8.12.3).

You will need magnetic deep metric socket 10mm with outside diameter not more than 11/16 in to unscrew the six bolts (Fig.8.12.3)(Fig.8.12.4) (Fig.8.12.5).

Driven Chain Wheel is composed by two symmetrical halves(Fig.8.12.6). Mount on the reverse order.

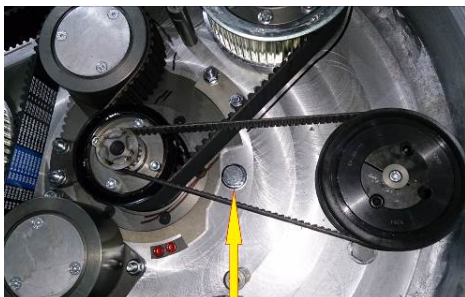

Figure 8.12.1



Figure 8.12.2

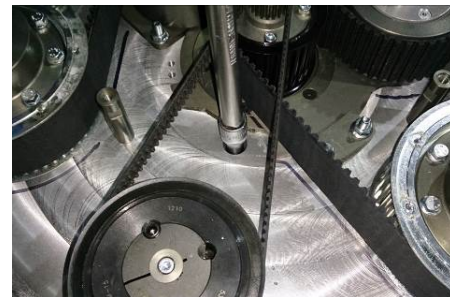

Figure 8.12.3



Figure 8.12.4

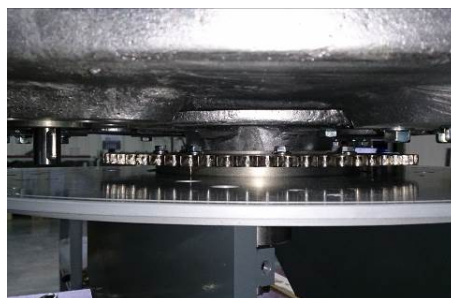

Figure 8.12.5



Figure 8.12.6

8.13 REPLACING THE PULLEY UNITS

Dismount guard, top cover, maintenance window chain tensioner, driven chain wheel, bottom cover and belts as previous described.



Figure 8.13.1



Figure 8.13.2



Figure 8.13.3

Unscrew the four bolts of each pulley between the base plate and the motor base disc (Fig.8.13.1)(Fig.8.13.2) and dismount the pulley (Fig.8.13.3).

A seal (Fig.8.13.4) should be placed on top of the pulley before mounting.



Figure 8.13.4

8.14 REPLACING THE PLANETARY UNIT



Figure 8.14.1



Figure 8.14.2



Figure 8.14.3

Unscrew the six bolts (Fig.8.14.1)(Fig.8.14.2) and press down the planetary unit. When mounting back secure with sealant (Fig.8.14.3).

9. DISPOSAL

If your machine after time is not usable or needs to be replaced, send the machine back to Superabrasive or a local distributor, where a professional disposal complying with the environment laws and directives is guaranteed.

10. MANUFACTURER'S CONTACTS

If you need to contact Superabrasive Inc. with technical support questions, below is the contact information.

Address: 9411 Jackson Trail Road, Hoshton GA 30548, USA
Email: info@superabrasive.us
Tel.: 706 658 1122
Fax: 706 658 0357
Website: www.superabrasive.com

11. SPARE PARTS

ASSEMBLY AND PARTS SPECIFICATIONS

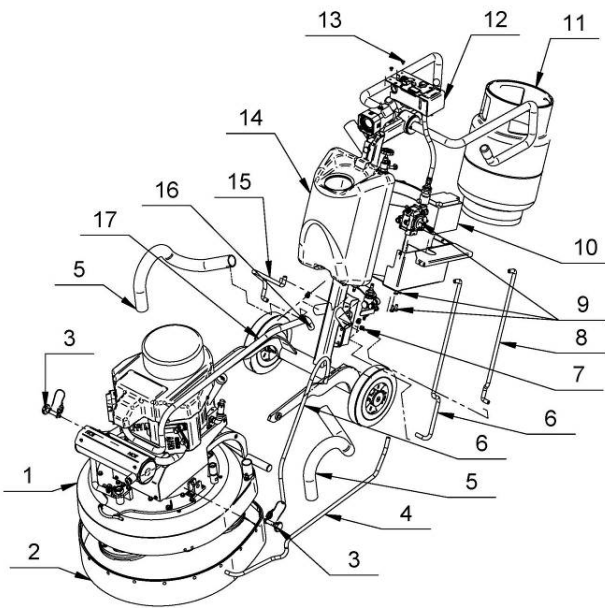

1. LAVINA® 25G-X GENERAL PARTS			
No.	Item No.	Description	Pcs.
1	L25GX-10.00.00	Main Head	1
2	L25SPS-05.00.00	Guard Assembly	1
3	L25SPS-07.03.00.00	Pin Assembly	2
4	MAR8.110	Tube	1
5	D40L700	Vacuum Hose	2
6	MAR8.85	Tube	2
7	10-16DIN3017	Clamp	3
8	MAR8.71	Tube	1
9	L25G-26.00.00	Regulator set	1
10	CC01-25968	12V Battery & Wire Connector	1
11	W2504	Propane Tank	1
12	L25GS-40.00.00	Control Board Ass.	1
13	M6X10ISO7380F	Screw	2
14	L25GX-20.00.00	Carriage With Control Box	1
15	MAR8.50	Tube	1
16	F0708750	Clamp	1
17	W2660	Tube	1

2. LAVINA® 25G-X TOP COVER 1 PARTS

No.	Item No.	Description	Pcs.
1	M6X16DIN6921	Bolt	2
2	L25G-10.00.69	Front Guard	1
3	M8X16DIN6921	Bolt	8
4	L25SPS-07.00.00.02-L	Left Fork	1
4.1	L25SPS-07.00.00.02-R	Right Fork	1
5	L25X-19.00.00	Top Cover Assembly	1
6	M6X10ISO7380F	Screw	5
7	L25NSPS-07.00.00.05	Back Weight Holder	2
8	L25SPS-07.00.00.29	Rubber Buffer	3
9	M10X75DIN931	Bolt	1
10	M10DIN127B	Spring Washer	1
11	A29.12.00	Spray Unit	1
12	H766-21	Handle	1
13	L25SPS-07.00.00.26	Stud	1
14	L25X-15.00.02	Washer	1
15	M8X20DIN6921	Bolt	8
16	L25S-15.00.04	Support Top L25-S	1
17	L25X-15.10.01	Nut	1
18	L25S-15.10.00	Bar Assembly L25-S	1
18.1	L25S-15.10.02	Lever	1
18.2	L25S-15.10.03	Spring L25-S	1
19	L25LX-15.11.00	Inspection Cover	1
20	L25X-18.00.00	Machine Support	1
20.1	L25GS-18.30.00	Clamp head	1
20.2	M8X16DIN6921	Bolt	4
21	M8X16DIN912	Screw	6
22	M8X20DIN7991	Screw	2

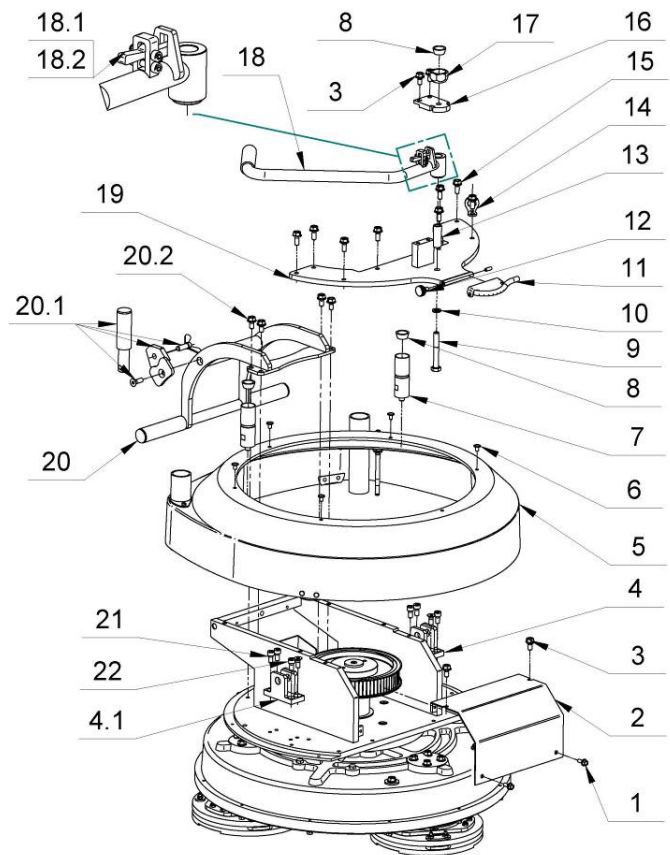

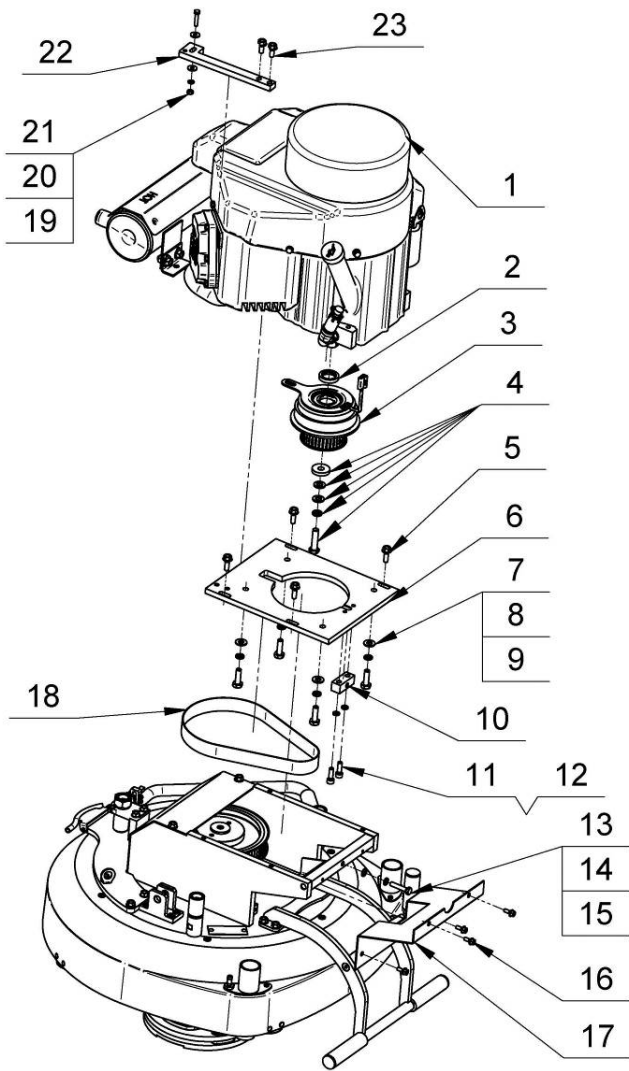

3. LAVINA® 25G-X ENGINE BASE PARTS			
No.	Item No.	Description	Pcs.
1	FS481VA-CS10-M	Kawasaki Engine	1
*2	L25GS-10.02.06	Clutch Washer	1
3	5215	Electric Clutch	1
4	L25G-10.02.02.S	Bolt Set	1
5	M8X25DIN6921	Bolt	4
6	L25G-10.00.65	Engine Base Plate	1
7	F33008	Washer	4
8	F33622	Washer	4
9	F13107	Bolt	4
10	L25G-10.00.66	Tensioning Device Support	1
11	M8X25DIN912	Screw	2
12	M8DIN7980	Spring Washer	2
13	M8X40DIN933	Bolt	1
14	M8DIN125A	Washer	6
15	M8DIN127B	Spring Washer	9
16	M6X16DIN6921	Bolt	4
17	L25G-10.05.00	Back Guard	1
18	OMEGAHP7608MHP30	Endless Transmission Belt	1
19	M6X30DIN933	Bolt	1
20	M6DIN127B	Washer	1
21	M6DIN9021A	Washer	2
22	L25G-10.00.67-02	Support	1
23	M8X20DIN6921	Bolt	2

* While dismantling the clutch use one Clutch Washer with item No L25G-S-10.02.06, instead of previously mounted two Washers with item No W1220.

4. LAVINA® 25G-X TOP COVER 2 PARTS			
No.	Item No.	Description	Pcs.
1	L25X-19.00.01	Top Cover	1
2	L25GS-19.10.00	Vacuum Port	1
3	L25X-19.20.00	Water Fitting	1
4	M12DIN985	Nut	1
5	M5DIN125A	Washer	4
6	M5DIN127B	Spring Washer	4
7	M5DIN934	Nut	4
8	L25SPS-04.01.00.00	Vacuum Port	1
9	M5X16DIN84A	Screw	3

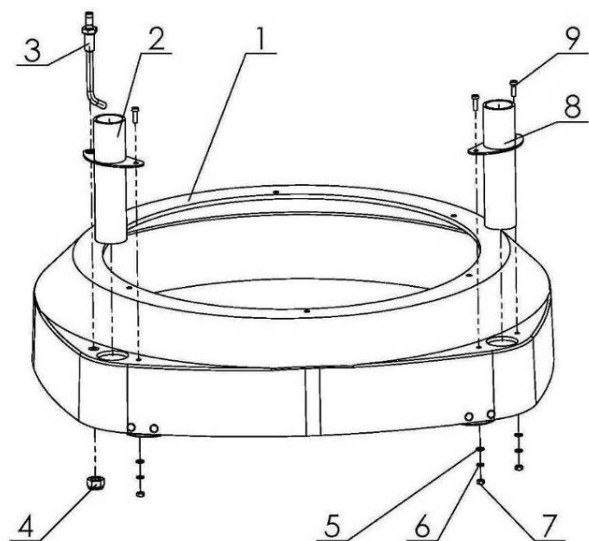

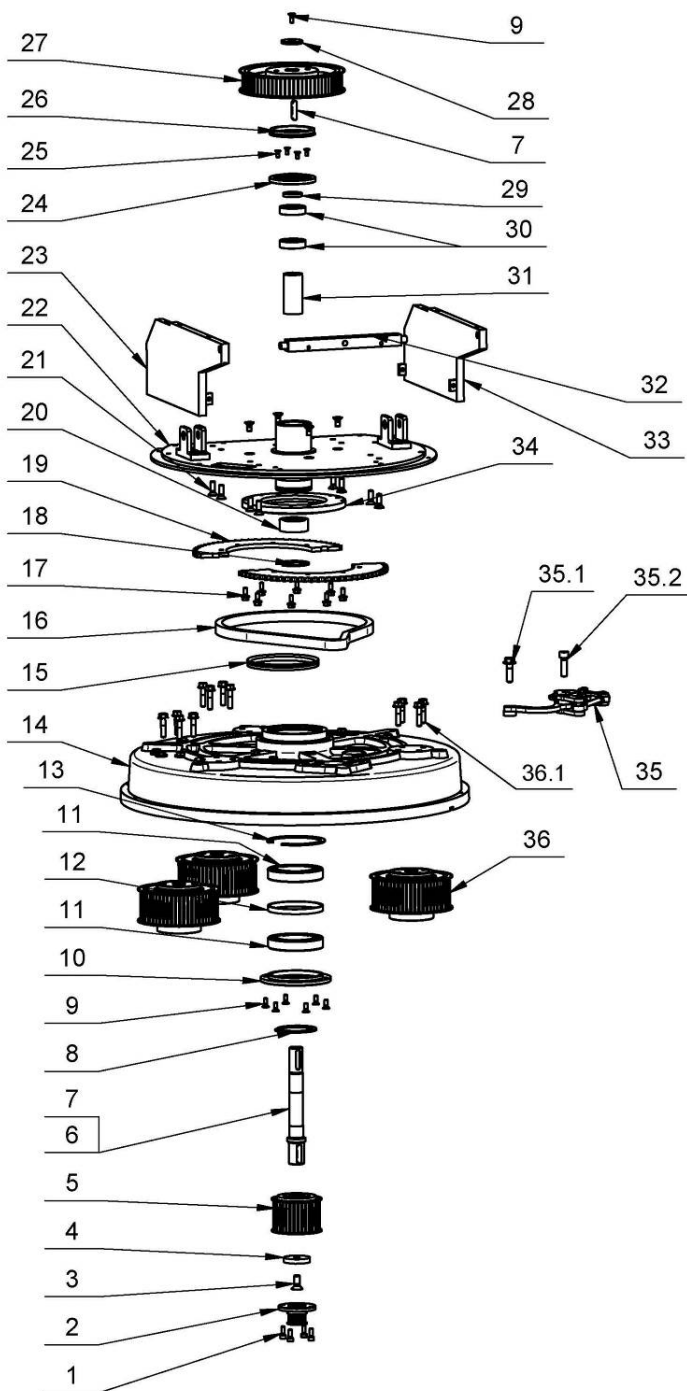

5. LAVINA® 25G-X PLANETARY DRIVE PARTS

No.	Item No.	Description	Pcs.
1	M6X16DIN912	Screw	4
2	L25X-03.00.00	Pulley	1
3	M10X25DIN7991	Screw	1
4	L25X-10.00.55	Front Washer	1
5	L25GX-10.10.00	Central Pulley	1
6	L25GX-10.00.57	Shaft	1
7	DIN6885A8x7x36	Key	2
8	B65DIN471	Retaining Ring	1
9	M6x16DIN7991	Screw	7
10	L25X-10.00.17	Cap	1
11	6013	Roller Assembly	2
12	L25SPS-00.00.00.34	Distance Ring	1
13	A10013943	Retaining Ring	1
14	L25X-10.00.01	Disc	1
15	TWVA01200	V-Ring Type A	1
16	08B-1-78	Chain	1
17	M6X16DIN6921	Bolt	8
18	A52DIN472	Retaining Ring	1
19	L25X-15.00.12	Chain Pulley	2
20	3205	Roller Assembly	1
21	M8X25DIN7991	Screw	8
22	L25GX-15.20.00	Base plate	1
23	L25GX-15.03.00	Left Plate Assembly	1
24	L25G-10.00.60	Cap for Rotary Seal	1
25	M5X12DIN7991	Screw	4
26	TWVA00700	V-Ring Type A	1
27	L25GX-10.30.00	Pulley Unit	1
28	L25SPS-00.00.00.15	Front Washer	1
29	L25G-10.00.59	Insert	1
30	6005	Roller Assembly	2
31	L25GX-10.00.58	Bushing	1
32	L25G-10.00.64	Support Plate	1
33	L25GX-15.04.00	Right Plate Assembly	1
34	L25X-15.00.03	Flange	1
35	L25X-17.00.00	Chain Tensioner	1
35.1	M10X35DIN6921	Bolt	1
35.2	M10x35DIN912	Screw	1
36	L25X-11.00.00	Pulley Unit Assembly	3
36.1	M8X35DIN6921	Bolt	4

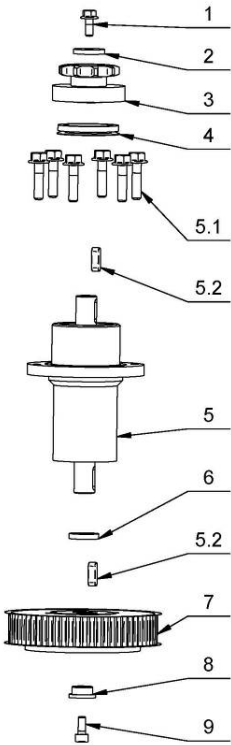

5.1. LAVINA® 25G-X PULLEY UNIT ASSEMBLY				
Model	No.	Item No.	Description	Pcs.
1	1	M5X12DIN6921	Bolt	1
2	2	L25X-10.00.46	Front Washer	1
3	3	L25X-16.20.00	Chain Pulley Assembly	1
4	4	TWVA00320	V-Ring Type A	1
5		L25X-16.00.00	Bearing Body	1
	5.1	M6X25DIN6921	Bolt	6
	5.2	DIN6885A5X5X16	Key	2
6	6	L25X-16.00.03	Distance Ring	1
7	7	TB64_5M-15-1210-14	Pulley Unit Assembly	1
8	8	L25X-10.00.44	Front Washer	1
9	9	M5X12DIN912	Screw	1

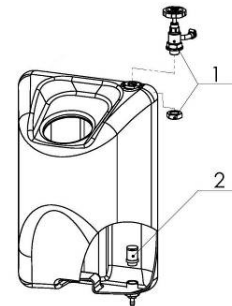

6. LAVINA®25G-S WATER TANK PARTS			
No.	Item No.	Description	Pcs.
1	A29.50.00	Regulator	1
2	1/2"	Filter	1

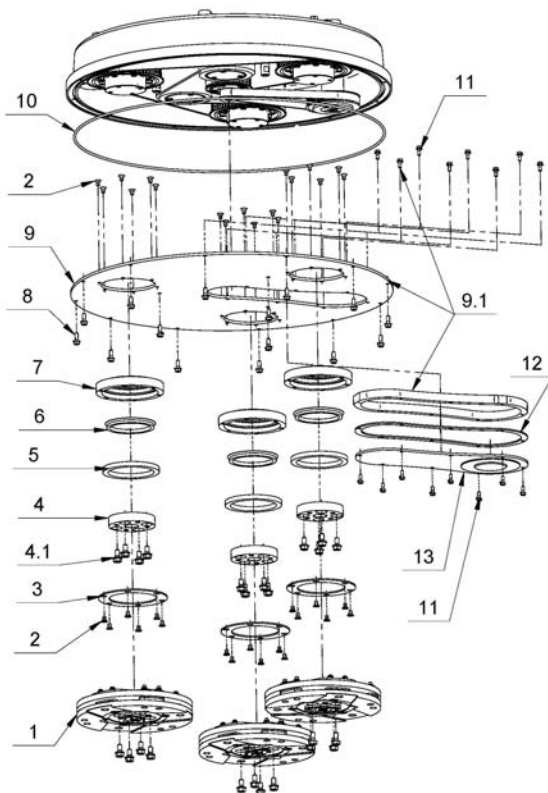

7. LAVINA® 25G-X BOTTOM COVER 1 PARTS				
No.	Item No.	Description	Pcs.	
1	A41.00.00	Tool Holder A41	3	
2	M6X10DIN7991	Screw	36	
3	L25LS-14.00.03	Outer Cover	3	
4	A42.03.00	Adaptor	3	
	4.1	M8x16DIN6921	Bolt	4
5	110X90X8.5	Felt Ring	3	
6	TWVA00800	V-Ring Type A	3	
7	L25LS-14.00.02	Flange	3	
8	M6x16DIN6921	Bolt	15	
9	L25X-14.00.00	Bottom Cover Assembly	1	
	9.1	L25X-14.00.01-K	Bottom Cover with manhole	1
10	D4X2X1880	Seal	1	
11	M5X12DIN6921	Bolt	16	
12	L25X-14.00.04	Sealer Inspection Cover	1	
13	L25X-14.10.00	Inspection Cover	1	

8. LAVINA® 25G-X TOOL HOLDER PARTS/SEE ALSO FIG.8.7.13/ (POS.1 INCLUDE POS.1.1;1.2;1.3/POS.1.3 INCLUDE POS.1.3.1 and etc.)

No.	Item No.	Description	Pcs.	
1	A41.10.00	Quick Change Assembly	1	
	1.1	A31.12.00	Keylock Set	1
	1.2	A41.11.00	Quick Change plate	1
	1.3	A41.12.00	Security set	1
		1.3.1	A41.00.05	Washer A41
2	A25.00.10-K	Buffer with two screw	6	
	2.1	M8X12DIN7991	Screw	12
	2.2	A25.00.10	Buffer	6
3	A41.20.03-K	Driving Set A41	1	
	3.1	A41.20.03	Elastic Element	1
	3.2	M6DIN985	Self Locking Nut	12
	3.3	M6X40DIN7991	Screw	6
	3.4	M6X30DIN7991	Screw	6
	3.5	A41.21.00	Set of plates	1
4	M8x16DIN6921	Bolt	4	
5	A41.20.01	Flange	1	

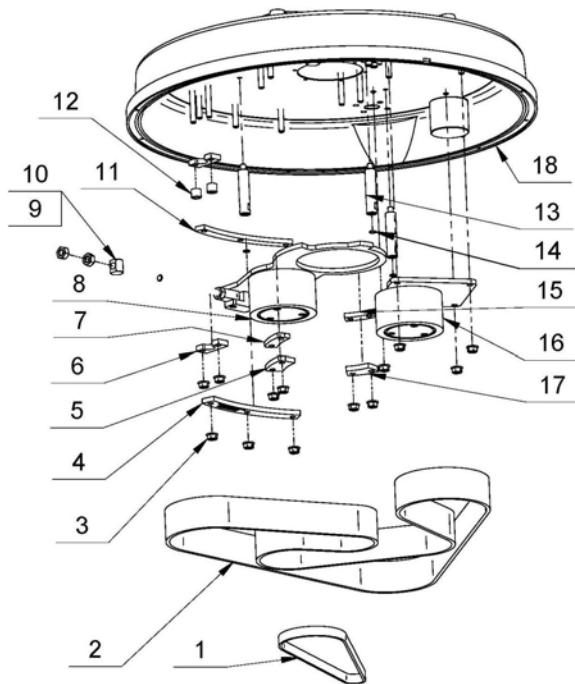
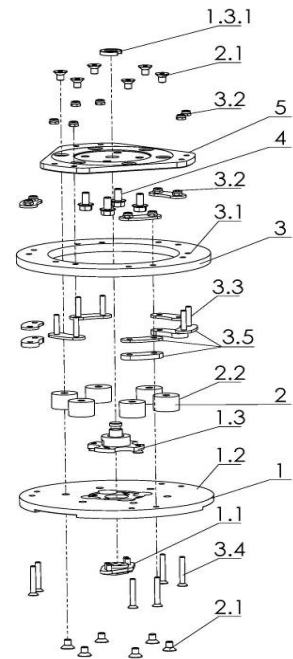

9. LAVINA® 25G-X BOTTOM COVER 2 PARTS

No.	Item No.	Description	Pcs.
1	HP6455MHP15	Timing Belts	1
2	HL24008MHL50	Timing Belts	1
3	M8DIN6923	Nut	13
4	L25L-10.00.14	Sector	1
5	L25L-10.00.12	Sector	1
6	L25L-10.00.07	Support	2
7	L25L-10.00.11	Sector	1
8	L25X-12.00.00	Tensioning Support	1
9	L32C-14.20.04	Nut	1
10	M10DIN934	Nut	2
11	L25L-10.00.13	Sector	1
12	L25L-10.00.08	Washer	2
13	L25X-10.00.13	Distance Bolt	3
14	D6X2	O-Ring	3
15	L25X-10.00.34	Sector	1
16	L25X-13.00.00	Deflection Pulley	1
17	L25X-10.00.35	Sector	1
18	L25X-10.00.01	Disc	1

10. LAVINA® 25G-X CONTROL BOARD PARTS

No.	Item No.	Description	Pcs.
1	W1301	Start/Stop Switch	1
2	W1330	Clutch Switch	1
3	W4110	Throttle	1
4	W4313	Hour Meter	1
5	6x30/30A	Fuse	1
6	W9999	Pump switch	1

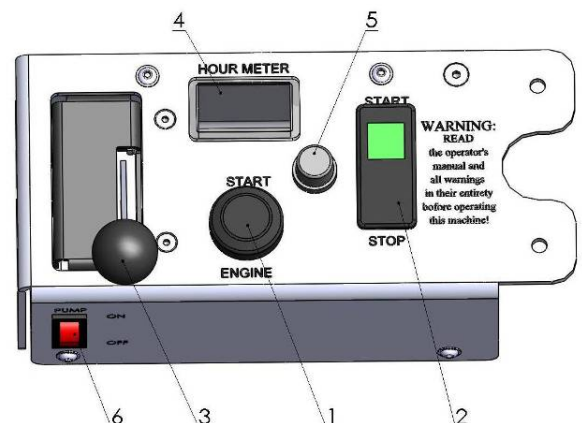

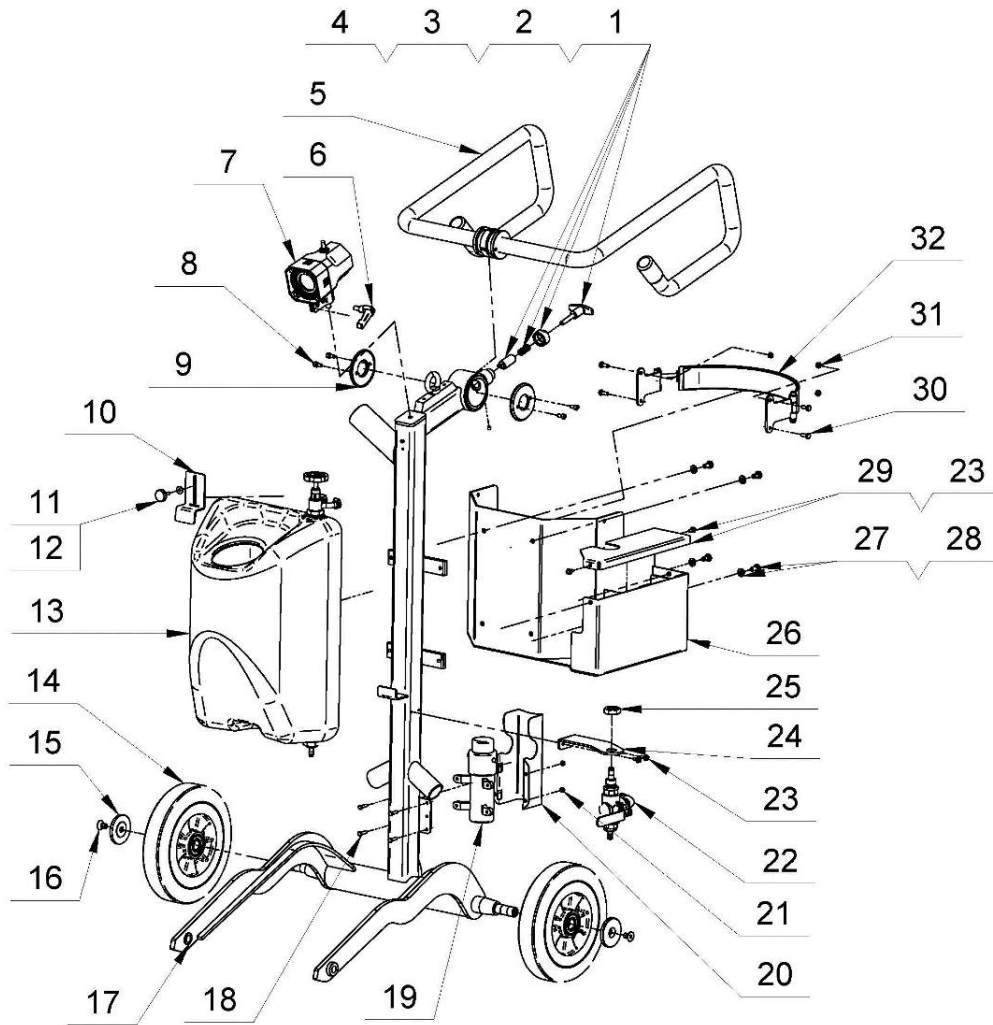

11. LAVINA® 25G-X CARRIAGE PARTS

No.	Item No.	Description	Pcs.	No.	Item No.	Description	Pcs.
1	L27160	Handle	1	17	L25GX-21.00.00	Frame	1
2	L25S-23.00.09	Nut	1	18	M5X20DIN933	Bolt	4
3	L25S-23.00.07	Spring L25-S	1	19	1040	Water Pump	1
4	L25S-23.00.06	Locking bit	1	20	L25S-20.00.26	Guard	1
5	L25S-23.10.00	Handle Assembly	1	21	M5DIN985	Nut	4
6	A58165	Swivel Bolt	1	22	A29.40.00	Water Flow Control Unit	1
7	L25SPS-01.00.00.00-G	Lamp Unit Incl. Cable	1	23	M5X12DIN6921	Bolt	4
8	M6X12DIN912	Screw	4	24	A29.20.01-01	Flow Unit Base	1
9	L25S-23.00.02	End Cover	2	25	M20X1.5DIN439B	Nut	1
10	L25P-02.00.00.01	Top Bracket	1	26	L25G-22.00.00	Propane Tank Holder	1
11	T34391	Knob Bolt	1	27	M8X16DIN933	Bolt	4
12	M5UN732	Washer	1	28	M8DIN125A	Washer	4
13	A33.10.00	Tank Assembly	1	29	L25G-20.00.05	Battery Cover	1
14	L25G-20.00.04	Wheel	2	30	M6X16DIN933	Bolt	4
15	L32D-20.00.03	Wheel Cap	2	31	M6DIN985	Nut	4
16	M10X16DIN7991	Screw	2	32	L25GS-25.00.00	Strap	1

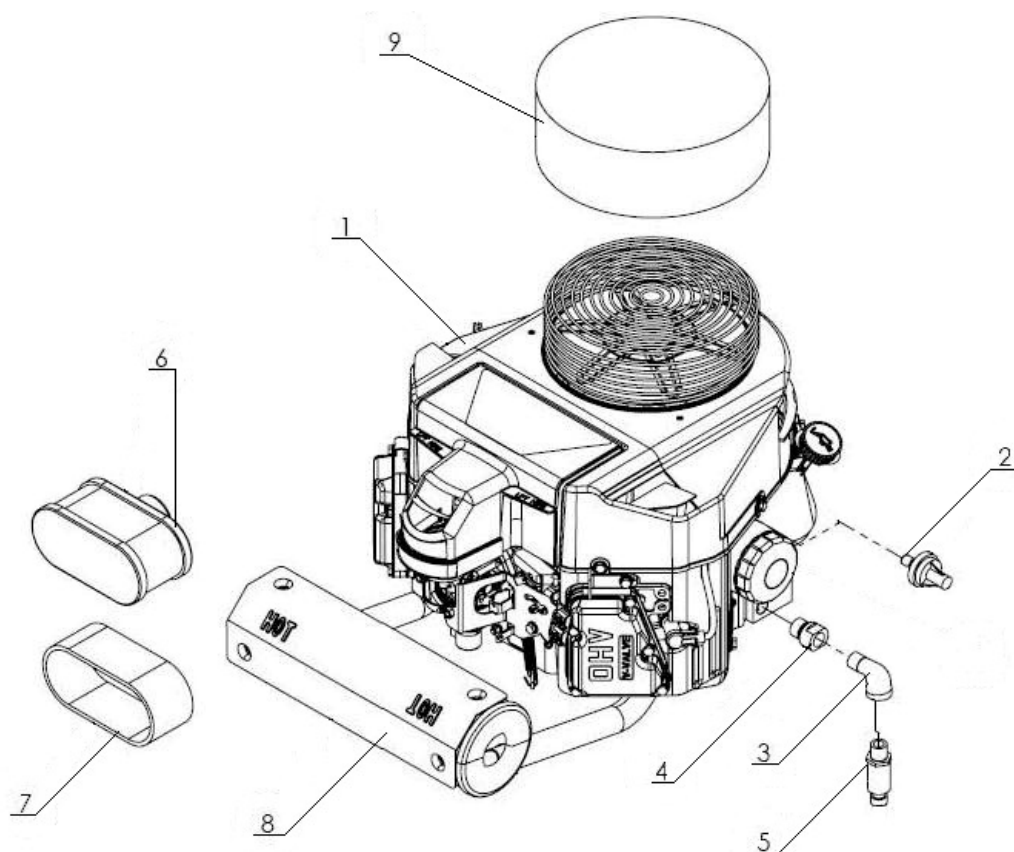

12. LAVINA® 25G-X ENGINE PARTS			
No.	Item No.	Description	Pcs.
1	W3132	Kawasaki FS481V-AS10-M 18H 12V	1
	K49065-7007	Oil Filter	12
2	W1325	Oil Pressure Switch	6
3	F466230	Elbow	1
4	K59071-7004	Joint	1
5	FE17409029909	Oil Drain Valve	1
6	K11013-7049	Element Air Filter	1
7	K11013-7046	Element Air Filter/ Fs481v (Foam pre-Filter)	1
8	W3241A	Cat Muffler Assy.	1
9	W3305	Kawasaki Bonnet Filter	1